



Introduction

This information provides details for chassis specifications for Volvo vehicles.

Note: We have attempted to cover as much information as possible. However, this information does not cover all the unique variations that a vehicle may present. Note that illustrations are typical but may not reflect all the variations of assembly.

All data provided is based on information that was current at time of release. However, **this information is subject to change without notice.**

Please note that no part of this information may be reproduced, stored, or transmitted by any means without the express written permission of Volvo Trucks North America.

Contents:

- “Frame Specifications”, page 3
- “Tightening Torques, Frame Rail Bolts”, page 5
- “Frame Rail Cutouts”, page 6
- “Crossmember Configurations”, page 10
- “Frame Rake and Height Calculation”, page 14
- “Bolt Hole Patterns”, page 17
- “Frame Design and Function”, page 18
- “Frame Reinforcements”, page 22
- “Subframes”, page 26
- “Minimizing Frame Failure”, page 29
- “Welded Attachments”, page 31
- “Frame Rails and Crossmembers”, page 33
- “Crossmembers”, page 37

- “Mounting Hardware and Brackets”, page 43
- “Rear Towing Configurations”, page 45
- “Towing Procedure”, page 48
- “Special Tools”, page 53
- “Frame Rail, Replacement”, page 54
- “Frame Alignment, Checking”, page 60
- “Frame Alignment, Adjustment”, page 61
- “Intermediate Crossmember, Replacement (Rivets Under the Frame Flange)”, page 63
- “Closing Crossmember, Replacement”, page 66
- “Rear Suspension Crossmember (Bogie), Replacement”, page 68
- “Frame Length, Adjustment”, page 73
- “Body Bound Bolt, Installation”, page 80
- “HUCKBOLT® Permanent Fastener, Removal”, page 81

Frame Specifications

Frame Rail

Frame Rail Section Configurations, With and Without Liners

Frame Rail Dimensions

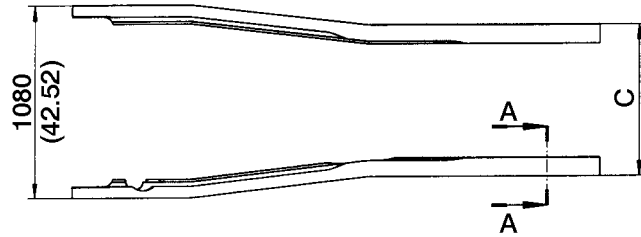

W9000359

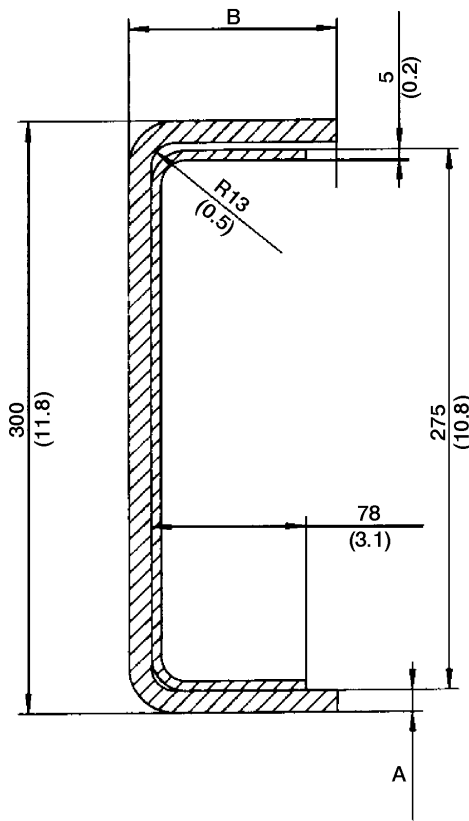

W9000360

Frame Rail Thickness	A	7 (0.28)	8 (0.31)	9.5 (0.37)	11.1 (0.44)	
Frame Rail Flange	B	90 (3.54)	90 (3.54)	90 (3.54)	90 (3.54)	105 (4.13)
Overall Frame Width	C	850 (33.46)	852 (33.54)	855 (33.66)	848.2 (33.40)	

Round-corner Frame

Frame Section Dimensions ¹ mm (in)	Section Modulus	Resisting Bending Moment	Weight/ft
	10 ³ mm ³ (in ³)	10 ³ Nm (in-lb)	kgs (lbs)
7 x 300 x 90 (0.28 x 11.81 x 3.54)	256 (15.7)	210.254 (1,884,000)	7.6 (16.7)
8 x 300 x 90 (0.31 x 11.81 x 3.54)	285 (17.6)	253.699 (2,112,000)	8.6 (19.0)
8 x 300 x 90 w/ 5 mm liner (0.31 x 11.81 x 3.54 w/ 0.20 liner)	429 (27.1)	362.923 (3,252,000)	12.7 (28.1)
9.5 x 300 x 90 (0.37 x 11.81 x 3.54)	334 (20.5)	274.536 (2,460,000)	10.2 (13.3)
10.47 x 3.54 x .24 (6 x 266 x 90)	334 (11.52)	154.275 (1,382,400)	10.2 (22.4)
10.47 x 3.54 x .28 (7 x 266 x 90)	384 (13.26)	177.577 (1,591,200)	7.07 (15.5)
10.47 x 3.54 x .31 (8 x 266 x 90)	429 (14.82)	198.469 (1,778,400)	8.03 (17.6)
11.1 x 300 x 90 (0.44 x 11.81 x 3.54)	385 (23.5)	314.712 (2,820,000)	11.7 (25.9)
11.1 x 300 x 105 (0.44 x 11.81 x 4.13)	431 (26.3)	352.209 3,156,000	12.5 (27.7)
9.5 x 300 x 90 with 5 mm liner (0.37 x 11.81 x 3.54 w/ 0.20 liner)	479 (29.2)	391.046 (3,504,000)	13.6 (31.5)
11.1 x 300 x 90 with 5 mm liner (0.44 x 11.81 x 3.54 w/ 0.20 liner)	524 (32.0)	428.544 (3,840,000)	16.6 (36.7)
11.1 x 300 x 105 with 5 mm liner (0.44 x 11.81 x 4.13 w/ 0.20 liner)	574 (35.0)	468.720 (4,200,000)	17.4 (38.4)

¹ Note: all figures are with rounded corners.

Available Frame Heights and Thicknesses

Frame height

Frame thickness

266 mm (VN) (10.47 in) 6 mm (.24 in), 7 mm (.27 in), 8 mm (.31 in)

300 mm (VN) (11.81 in) 7 mm (.27 in), 8 mm (.31 in)

300 mm (VHD) (11.81 in) 7 mm (.27 in), 8 mm (.31 in), 11.1 mm (.44 in)

Tightening Torques, Frame Rail Bolts

(for property class 10.9 bolts (Grade 8) and property class 10 nuts)

Bolt Size	Torque
M6	12 ± 2 Nm (9 ± 1.5 ft-lb)
M7	22 ± 3 Nm (16 ± 3 ft-lb)
M8	30 ± 5 Nm (22 ± 4 ft-lb)
M10	60 ± 10 Nm (44 ± 7 ft-lb)
M12 (bolts crossmembers together)	105 ± 20 Nm (78 ± 13 ft-lb)
M14 (bolts crossmembers to frame)	200 ± 33 Nm (148 ± 24 ft-lb)
M16 (bolts crossmembers to frame)	275 ± 45 Nm (204 ± 34 ft-lb)
M18	360 ± 55 Nm (267 ± 44 ft-lb)
M20 (bolts cab mounts to frame)	540 ± 90 Nm (400 ± 67 ft-lb)
M22	730 ± 120 Nm (541 ± 90 ft-lb)
M24	900 ± 140 Nm (667 ± 111 ft-lb)

Proper frame bolt thread engagement Max. 13 mm past nut, min. two (2) threads

Frame Rail with Liners

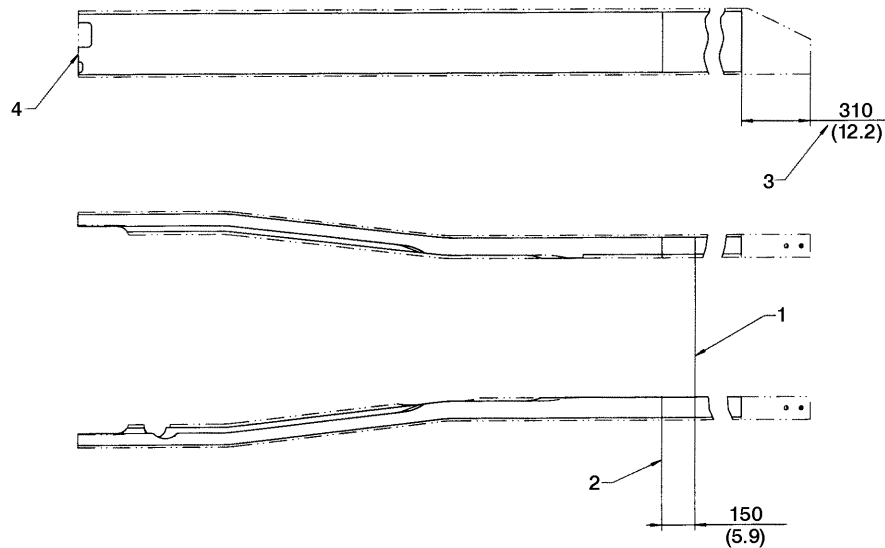

W7001159

Frame Rail Section Configurations with Liners

- 1 Back of cab
- 2 Partial liners begin at XM 4375 or 150 mm (5.91 in) forward of back of cab.
- 3 Liners for straight rails extend full length of frame. Tapered frames have liners that end 310 mm (12.2 in) from the back end of frame allowing for taper.
- 4 Full-length liners extend to the front of frame regardless of front frame extension length.

Frame Rail Cutouts

90 mm (3.54 in) Flange

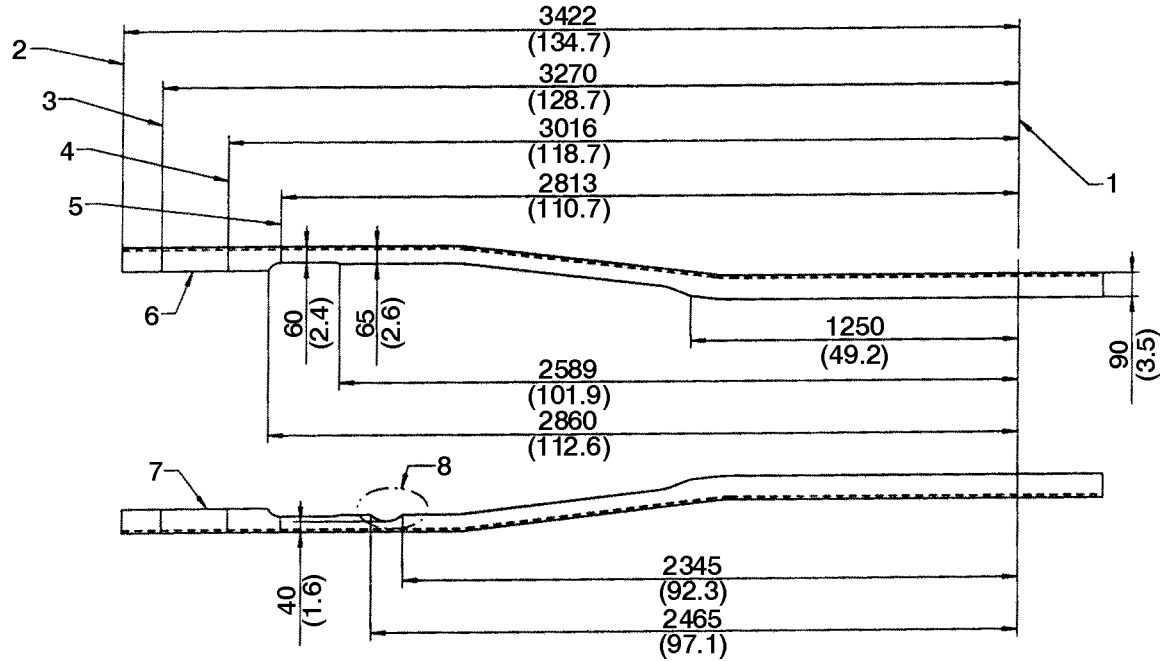

W7001164

Frame Rail Cutouts, 90 mm (3.54 in) Flange, Upper

- 1 Back of cab
- 2 Frame with 610 mm (24 in) front extension
- 3 Frame with 457 mm (18 in) front extension
- 4 Frame with 203 mm (8 in) front extension
- 5 Standard frame length
- 6 Upper right flange
- 7 Upper left flange
- 8 Axle forward steering gear cutout

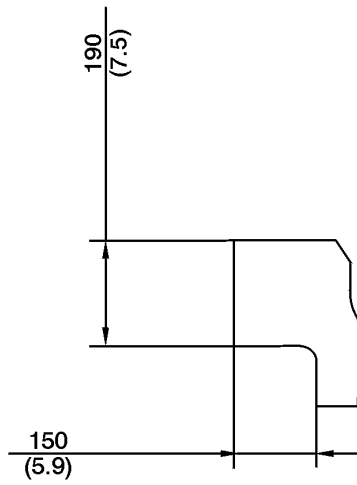

W7001166

Side Rail Cutout for 203 mm (8 in) Front Frame Extension Only

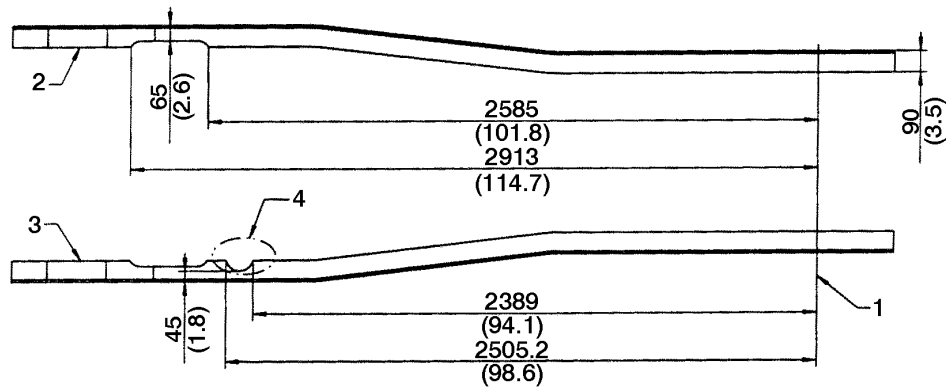

W7001165

Frame Rail Cutouts, 90 mm (3.54 in) Flange, Lower

- 1 Back of cab
- 2 Lower right flange
- 3 Lower left flange
- 4 Axle forward steering gear cutout

105 mm (4.13 in) Flange

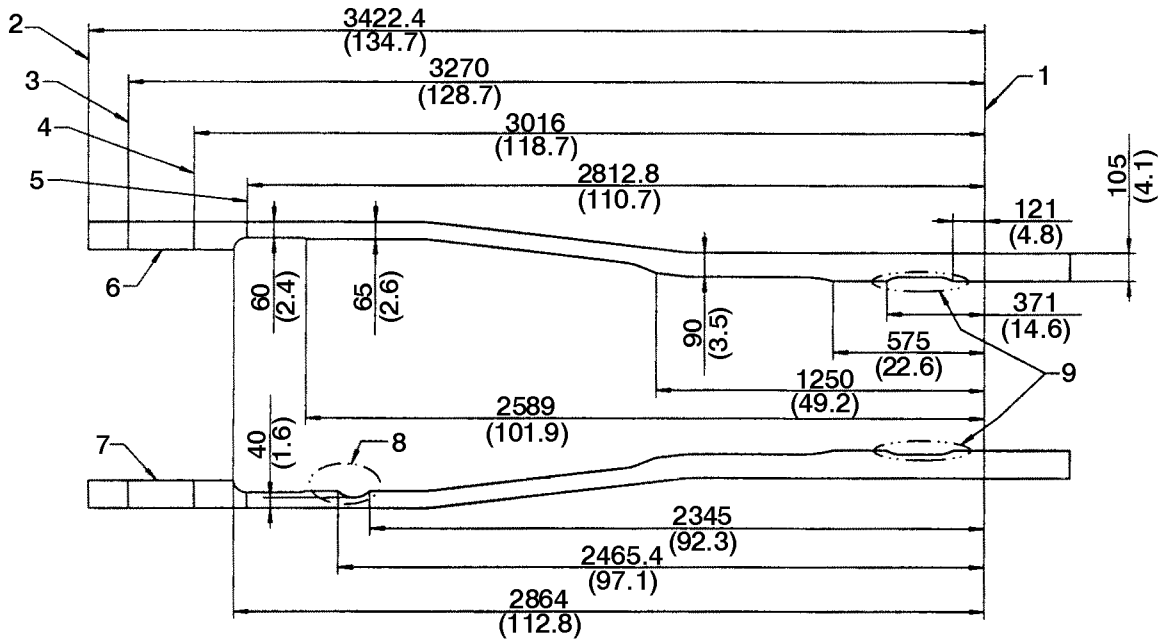

W7001161

Frame Rail Cutouts, 105 mm (4.13 in) Flange, Upper

- 1 Back of cab
- 2 Frame with 610 mm (24 in) front extension
- 3 Frame with 457 mm (18 in) front extension
- 4 Frame with 203 mm (8 in) front extension
- 5 Standard frame length
- 6 Upper right flange
- 7 Upper left flange
- 8 Axle forward steering gear cutout
- 9 HD transmission without retarder cooler piping cutout

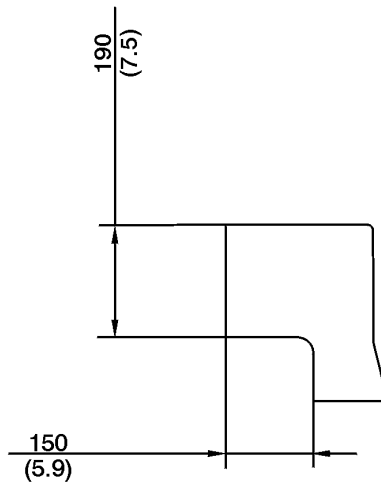

W7001163

Side Rail Cutout for 203 mm (8 in) Front Frame Extension Only

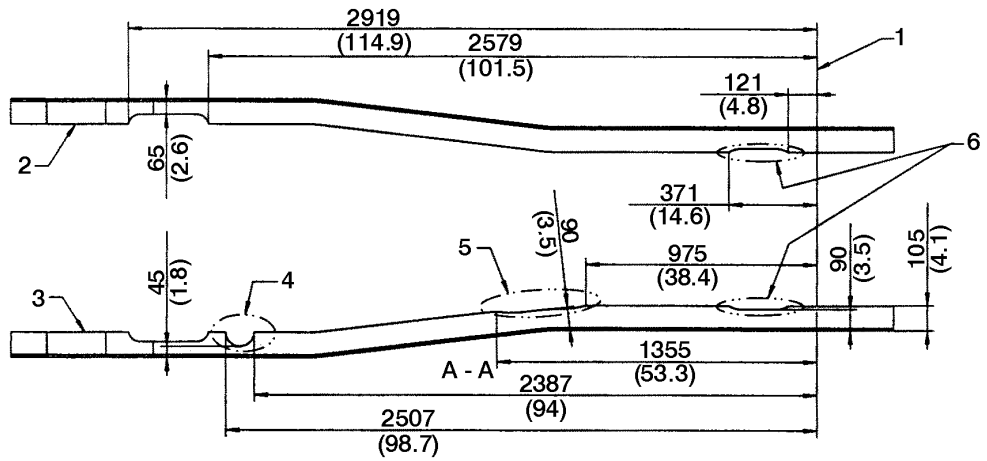

W7001162

Frame Rail Cutouts, 105 mm (4.13 in) Flange, Lower

- 1 Back of cab
- 2 Lower right flange
- 3 Lower left flange
- 4 Axle forward steering gear cutout
- 5 CU11 starter cutout
- 6 HD transmission without retarder cooler piping outlet

Crossmember Configurations

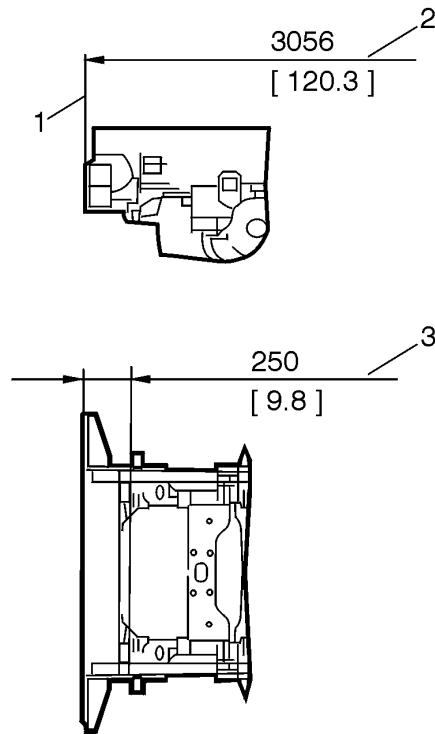

W5001176

View A: HD Front Closing Crossmember with 8 in Frame Extension

- 1 Front face of crossmember
- 2 To back of cab
- 3 Mounting bracket envelope

Notes

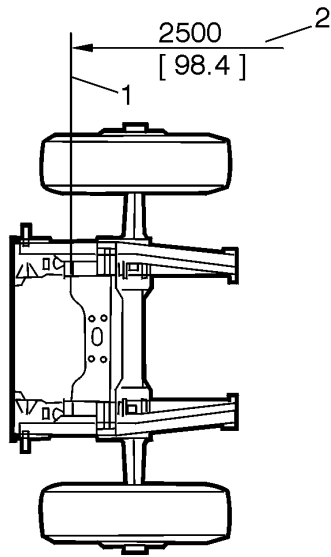

W5001177

View B: Engine Crossmember Shown Rotated 180° for D11/D13 and Cummins Engine

- 1 Front face of crossmember
- 2 To back of cab

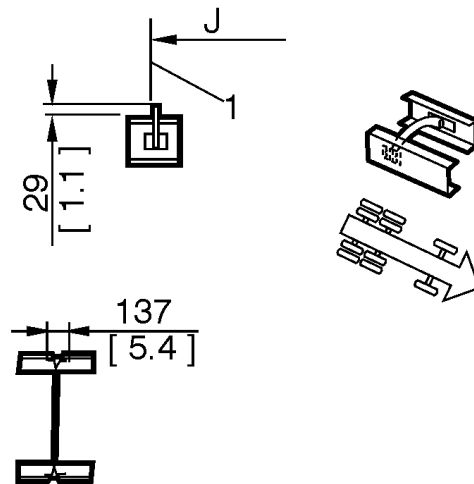

W5001178

View C: Optional Crossmembers

- 1 To back of cab
- J See chart

Values for "J"	
With Cummins and Fuller Autoshift	843 mm (33.2 in)
With D11/D13 and Allison MD	793 mm (31.2 in)
With D11/D13 and Fuller Autoshift	

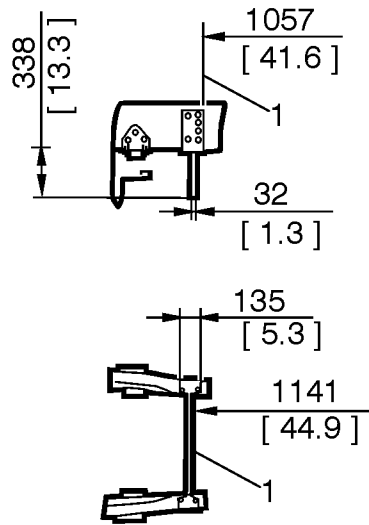

W5001179

View D: Underslung Crossmember Used with Allison HD Transmission or Flywheel PTO

1 To back of cab

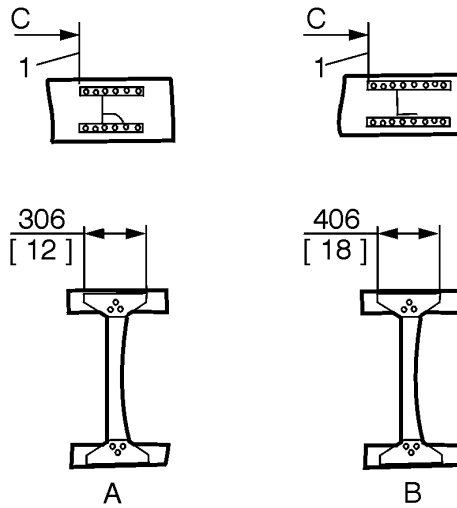

W5001171

View E

1 To back of cab

A Standard Center Bearing Crossmember

B Center Bearing Crossmember with fixed pusher axle

C Crossmember location (dimension C) established from prop shaft calculations.

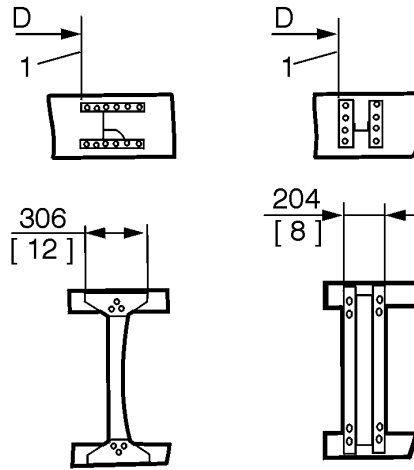

W5001172

View F: Extra Crossmember Options (Standard and Aluminum Version)

- 1 To back of cab
- D Crossmember location (dimension D) established from prop shaft calculations. This crossmember will be present if space between the crossmembers is too large per the calculations. (In this application, the crossmember may be replaced with an aluminum crossmember as shown in View J.)

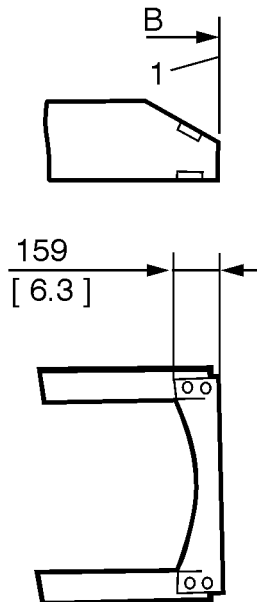

W5001173

View G: Rear of Frame with Tapered End (Tractor Only)

- 1 To centerline of rear axle

Frame Rake and Height Calculation

Note: VHD Only

Negative Frame Rake

Note: This calculation is used when "U" variable is greater than "W" variable.

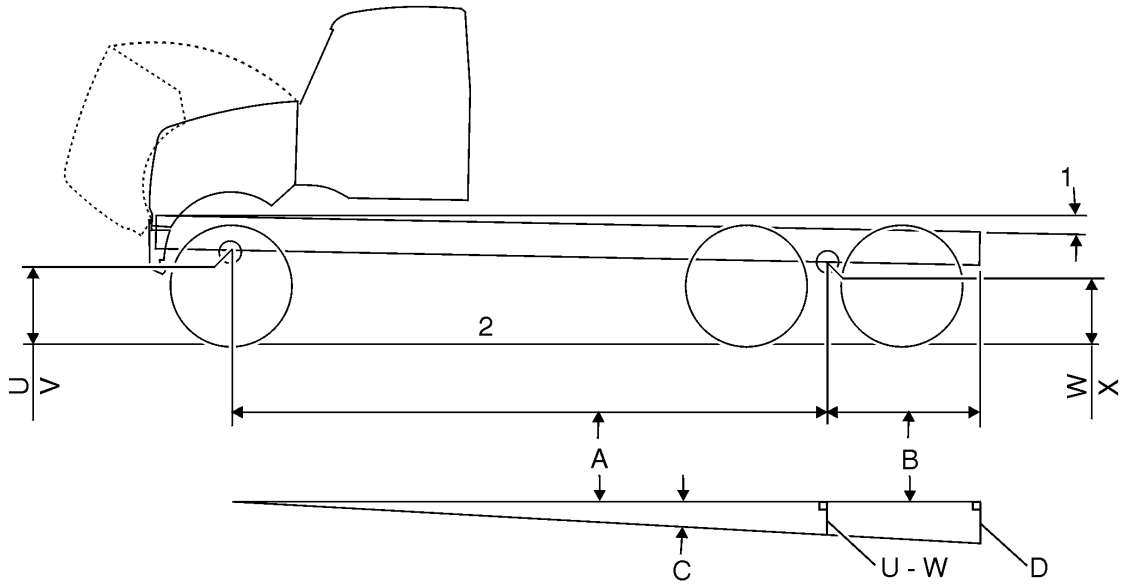

W7001191

Negative Frame Rake

- 1 Negative frame rake angle
- 2 Ground
- A Wheelbase
- B Rear frame overhang
- C Frame rake angle
- D Relative distance of rear frame edge to ground
- U Light; for variables, see Front Suspension information.
- V Loaded; for variables, see Front Suspension information.
- W Light; for variables, see Rear Suspension information.
- X Loaded; for variables, see Rear Suspension information.

To Calculate Frame Rake Angle

$$\text{TAN (Frame Rake Angle)} = \frac{\text{U - W}}{\text{Wheelbase}} \quad \text{Light Load}$$

To Calculate Frame Height to Ground At Rear of Frame

1. Distance "D" = TAN (Frame Rake Angle) x (Wheelbase + Rear Frame Overhang)
2. Frame Height to Ground (To Top of Frame) = (U - "D") + 300 (where 300 is Frame Rail Depth)

Positive Frame Rake

Note: This calculation is used when "W" variable is greater than "U" variable.

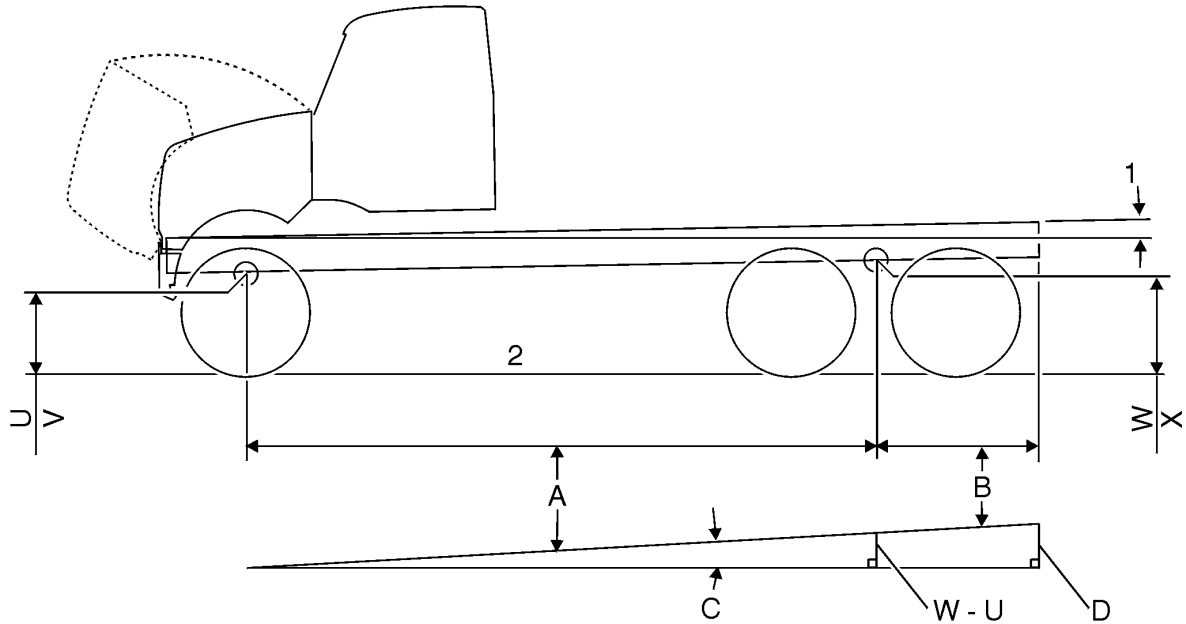

W7001190

Positive Frame Rake

- 1 Positive frame rake angle
- 2 Ground
- A Wheelbase
- B Rear frame overhang
- C Frame rake angle
- D Relative distance of rear frame edge to ground
- U Light; for variables, see Front Suspension information.
- V Loaded; for variables, see Front Suspension information.
- W Light; for variables, see Rear Suspension information.
- X Loaded; for variables, see Rear Suspension information.

To Calculate Frame Rake Angle

$$\text{TAN (Frame Rake Angle) = } \frac{W - U}{\text{Wheelbase}} \quad \text{Light Load}$$

To Calculate Frame Height to Ground At Rear of Frame

1. Distance "D" = TAN (Frame Rake Angle) x (Wheelbase + Rear Frame Overhang)
2. Frame Height to Ground (To Top of Frame) = (U + "D") + 300 (where 300 is Frame Rail Depth)

Frame Rails

Material 827.3 MPa (120,000 psi) yield heat treated steel

Distance between rails

Front 1080 ± 2 mm (outside)

Rear 836, 826 or 816 +2.7/-4.6 mm

Frame rail end taper 27°

Available Frame Heights and Thicknesses

Frame height	Frame thickness
266 mm (VN)	6 mm, 7 mm, 8 mm
300 mm (VN)	6 mm, 7 mm, 8 mm, 9.5 mm, 11.1 mm
300 mm (VHD)	7 mm, 8 mm, 9.5 mm, 11.1 mm

Notes

Bolt Hole Patterns

Hole spacing rear of the second bend 60 mm (2.26 in) (vert) x 50 mm (1.97 in) (horiz)

(applicable only from 1685 mm (65.2 in) from front edge of the rail and rearward). Some components may occupy non-grid locations.

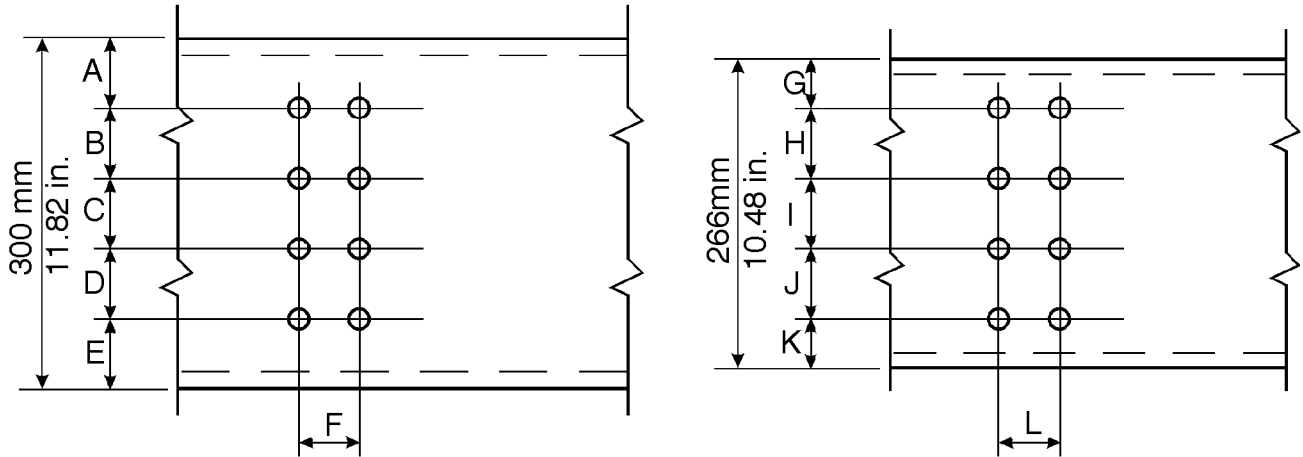

W7001187

- | | |
|--------------------------|--------------------------|
| A 60 mm (2.36 in) | G 43 mm (1.69 in) |
| B 60 mm (2.36 in) | H 60 mm (2.36 in) |
| C 60 mm (2.36 in) | I 60 mm (2.36 in) |
| D 60 mm (2.36 in) | J 60 mm (2.36 in) |
| E 60 mm (2.36 in) | K 43 mm (1.69 in) |
| F 50 mm (1.97 in) | L 50 mm (1.97 in) |

Note: Hole size for this spacing must be 15.5 mm (0.61 in) diameter.

Frame Design and Function

Frame

The truck frame is the backbone of the truck. Its primary function is to provide structural support to the truck and its components. Since all truck components are directly or indirectly attached to the frame, satisfactory operation of the truck depends on proper frame alignment and integrity.

The frame also functions as a mounting platform for the body and equipment to be used. It transmits the loads imposed by these attachments to the ground through the suspension and axles. The interaction of the body and frame is critical to the performance and life of the truck, and is a major focus of the following information.

The most common type of frame used in trucks today is the steel C-channel (see Fig. 1 Steel "C" Channel Frame). The steel channel frame is popular because components can be attached to it easily, and it exhibits relatively high strength compared to other shapes. It is fairly easy to modify and is compatible with several types of reinforcements. Channels are available in a wide variety of shapes and sizes making it easy to specify an optimum size for a particular application.

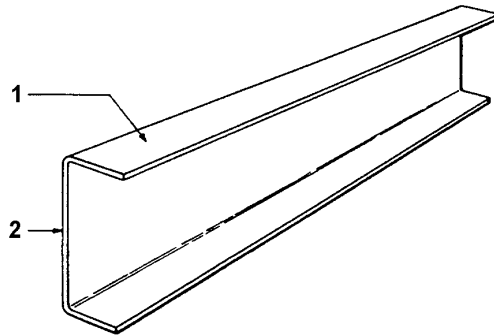

W9000289

Fig. 1 Steel "C" Channel Frame

- 1 Flange
- 2 Web

I-beams or wide flange beams are used by some heavy truck manufacturers and crane manufacturers (see Fig. 2 I - Beam Frame). These beams offer a very high section modulus which is important in crane applications. However, because of difficulty in mounting components to I-beams, they are not widely used in this industry.

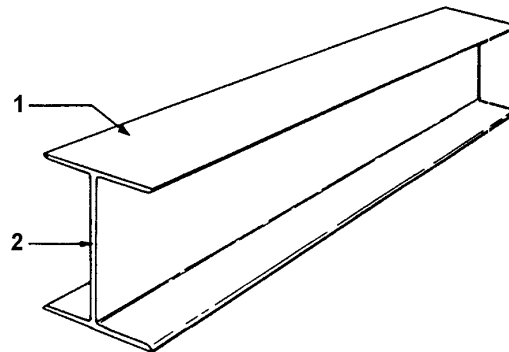

W9000290

Fig. 2 I - Beam Frame

- 1 Flange
- 2 Web

Frame Performance

Section Modulus

The section modulus (Z) of a frame rail is a number that mathematically represents an analysis of the cross sectional area of the load-carrying member (frame) related to the center or neutral axis of the rail. This value is obtained by use of a complex formula. The section modulus is a function of the shape and size of the frame rail and not the material used in it.

Because section modulus numbers quoted by the various OEMs are calculated differently, direct comparisons between manufacturers may be difficult.

For example, some manufacturers may use maximum tolerance dimensions to show maximum SM, rather than design SM. Others may use square corner vs. round corner calculations. Still others who wish to make calculations less complex may use simple rather than actual cross section.

There are no industry standards for proper calculation of section modulus. However, all agree that SM is critical to the proper application of heavy-duty trucks. The following information covers calculation of SM and Resisting Bending Moment (RBM) numbers using the standard method.

Example

We can calculate the relative load-carrying ability of a 50 mm x 250 mm (2" x 10") floor joist placed on its edge compared to using it in a flat position.

It is easily determined that the vertical position (on its edge) of the floor joist offers greater load-carrying ability. In fact, the calculation shows that the vertical position (33.3) is approximately 5 times greater than the horizontal position (6.7).

However, the calculation does not consider the type of material of the joist; it only takes into account the shape and position. Therefore, it does not indicate whether either position will support the weight (load) of the floor.

Note: In the expression of SM, the units of measure shown (cubic inches) are not used for a measure of volume or any other dimension. They are simply used as comparative units.

$$\text{Section Modulus} = \frac{WH^2}{6}$$

(W = Width; H = Height)

Section Modulus of a Truck Frame Rail

Several engineering properties are used in the design of a frame side member; these affect its cross section. The most significant properties are Moment of Inertia and Section Modulus. While the general principal (described above) is used to calculate the truck frame Section Modulus, the mathematics and dimensions are much more complex.

Moment of Inertia

The Moment of Inertia is defined as the sum of the products obtained by multiplying each small area of the cross section (dA) by the square of its distance (y) from a reference axis:

$$\text{Moment of Inertia of small area} = y^2 dA$$

Moment of Inertia (I) of entire section is:

$$I \text{ (around defined axis)} = \int y^2 dA$$

The Moment of Inertia of a beam cross section is one factor used to determine the deflection of that beam under load and its dynamic response characteristics. It becomes clear that a complex computer program is required to determine the Moment of Inertia with acceptable accuracy, particularly for the "small area" cross sections in the outer corner radii. The units of Moment of Inertia are in⁴.

Section Modulus and Load-carrying Ability

Section modulus is another complex engineering property for beam cross sections and is a factor in the flexural strength (load-carrying ability) of the beam. It considers the shape, height, flange width, and material thickness of the side member.

It is defined as the Moment of Inertia divided by the distance from the neutral axis to a location of interest within the cross section.

$$\text{Section Modulus} = \frac{I}{C}$$

The Section modulus relates to the stress in a beam cross section. Therefore, the maximum stress generally occurs at the outer surface that is the greatest distance from the neutral axis. The units of section modulus are in³.

Non-symmetric sections (i.e. a side member channel with an inverted "L" reinforcement) have two section modulus values. In this case, the maximum bending stress occurs at the location with the minimum section modulus value (the location that is the greatest distance from the principal axis).

In a single channel (see illustration), since the same section modulus value applies for both top (1) and bottom (2) surfaces, bending stress is the same at either surface.

However, with an "L" reinforcement (see illustration), the section modulus value for the top surface (3) is greater than that of the bottom surface (4). As a result, bending stress is higher at surface 4 where the section modulus value is lower.

Unfortunately, some truck manufacturers relate the section modulus to the strong side of a frame when an "L" reinforcement is used. This overvalues the section modulus by as much as 48%.

Dimensions

In section modulus calculations for truck frames, results can vary significantly depending on which dimensions are used. Generally, dimensions stated may cover the range of tolerances on both the design of the part and the material used to fabricate it.

For example, the following section modulus (see the below table) is calculated using (1) the maximum tolerance dimensions and (2) the actual design dimensions.

If a customer specification requires a 10.0 in³ Section Modulus, a 10.000" x 3.000 in x 0.250 in frame will meet that spec, but only if the maximum tolerances are used for the calculation. It is highly unlikely that a frame would be produced with all dimensions at maximum; therefore, the maximum tolerance section modulus is not a representative number for comparison. Instead, the design dimensions should be used as the most accurate measurement.

Description	Depth	Width	Thickness	Section Modulus (in ³)	
				Max. Tolerance (1)	Design (2)
Single Channel Rail	10.000 in	3.000 in	0.250 in	10.86	9.93

Yield Strength

Section modulus can provide an accurate comparison of relative load-carrying capability based on the shape of a frame section. However, we must also compare the strengths of the various materials that are used in truck frames.

The material chosen for the frame depends on the strength required for the application. There are three types of steel commonly used in truck frames today:

- Low Carbon or Mild Steel: 30,000–50,000 psi
- High Strength Low Alloy: 50,000–110,000 psi
- Heat Treated: 120,000 psi

The strength of the steel used is expressed as the yield strength. This value, expressed in pounds per square inch (psi), is the maximum stress the material can withstand without experiencing permanent deformation or damage.

For example, if a test bar 1 in x 1 in (1 in² cross section) is pulled to its limit without permanent set and the load is 22,679 kg (50,000 lb), the material is said to have a yield strength of 344,737 kPa (50,000 psi).

Yield strength, like section modulus, is subject to interpretation. Some truck manufacturers list the tensile or ultimate strength of their frame material. Using the example above, the test bar would be pulled until it broke, which would occur at a load of 31751 kg (70,000 lb). This would indicate a tensile or ultimate strength of 482,633 kPa (70,000 psi). But this number has little relevance in truck frames, since loading must be kept below the yield strength to keep the frame from being permanently bent.

Another strength number called “Rated Yield Strength” is used by some truck manufacturers, particularly for a steel called “Van 80.” When tested, Van 80 will yield at 551,580 kPa (80,000 psi); however, the manufacturer rates it as “equivalent to 758,423 kPa (110,000 psi)” based on the fatigue strength of the material.

The yield strength of the steel is determined in a testing laboratory, by subjecting samples to tensile tests.

Resisting Bending Moment

Section modulus numbers compare the relative load-carrying ability of various frame section shapes without regard to frame material. Yield strength information compares the strength per unit area of frame material without regard to its shape.

Resisting Bending Moment (RBM) provides a method to compare the actual load-carrying capability of frames of various shapes and materials.

The resisting bending moment (RBM) is defined as the yield strength (S) multiplied by the section modulus (Z).

Formula: $RBM = S \times Z$

The RBM is important because it represents the maximum bending moment that the frame rail can withstand without permanent deformation or damage. The RBM is usually expressed in inch pounds per rail.

For truck frames that have cross sections that vary from front to rear (for example, drop center frames), RBM is based on the Section Modulus of the frame at the back of the cab. When RBM is calculated for an aluminum frame with steel reinforcement, the yield strength of the aluminum is used for the calculation, since the aluminum is the lower strength material. When the RBM calculation is made for a steel frame with a steel reinforcement (each with a different yield strength), the yield strength and dimensions of the material with the lower yield strength number are used for the calculation.

The actual bending moment and its units (in-lb) represent a physical characteristic of the frame. It is a load multiplied by a distance from a support point (an axle) that the frame can carry without permanently bending. For example, a typical fifth wheel load is 22,000 lb and may be 12 in ahead of the rear axle center line. Mathematically, the 22,000 lb force has a “moment” — or lever arm — of 12 in that is trying to bend the frame. This means that the frame must **Resist a Bending Moment** of 27,000 x 12, or 324,000 in-lb for two rails, or 162,000 in-lb per rail.

A frame with an RBM much higher than the actual bending moment would be specified to allow for extra forces put on the frame when the truck encounters rough roads and to assure long-term resistance to fatigue as the frame is loaded and unloaded over the lifetime of the truck.

Frame Reinforcements

Most trucks are built with frame rails that are strong enough to handle average loads such as those imposed by a van body or platform body. When bodies or equipment are installed that cause the stresses in the frame to exceed the manufacturer's recommendations, additional reinforcement of the frame is necessary. Reinforcements that could be used include: double channels, fish plates, 'L' shapes, and angle reinforcements (see Fig. 3 Frame Reinforcements).

These reinforcements could be combined to provide additional strength when required.

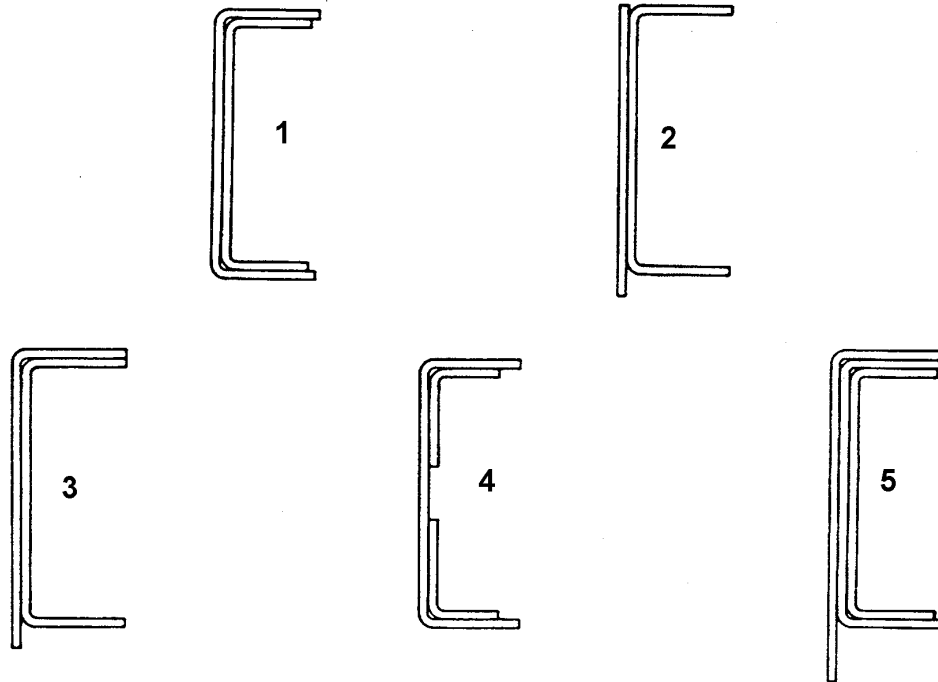

W9000291

Fig. 3 Frame Reinforcements

- 1 Inner Channel Liner
- 2 Fish Plate
- 3 Inverted 'L'
- 4 Inside Angles
- 5 Combination of Inner Liner and inverted 'L'

Channel Reinforcements

Channel reinforcements can be installed on the inside or outside of the existing frame rails (see Fig. 4 on page 23). Because of the difficulty in installing a channel on the outside of an existing frame rail, only inner channel reinforcement is recommended.

Inner channel reinforcements may be required to extend the full length of the frame or only a portion of it. Normally, inner channels are not installed forward of the rear engine mount. Installation of an inner channel ahead of this point requires extensive modification of the truck; normally the stresses in this area are not high enough to require additional frame reinforcement.

On certain models, center crossmembers are designed for 1/4 in frame liners. On trucks and tractors with single channel frames, 1/4 in spacers are used in conjunction with the crossmembers. The spacers must be used when adding an inner reinforcement to the frame. Engine mounts and bogie crossmembers for Hendrickson rear suspensions also use spacers. Volvo T-Ride bogie crossmembers do not, and must be changed to accommodate inner liners.

Note: Bend radius of inner channel should be large enough so that the corners of the two channels do not touch each other.

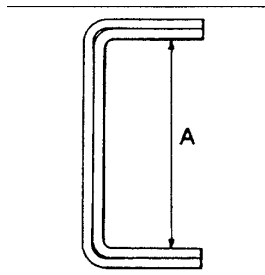

W9000295

Fig. 4 Inner Channel Liner

The ends of the inner channel should be tapered 45°, as shown in Fig. 5 End Taper, Inner Channel Liner, except at the rear of the frame where the liner may be cut squarely. The ends of a liner should not terminate at the center of a suspension bracket or crossmember, but should continue completely through the bracket and then begin the tapering.

When necessary modifications to the crossmembers have been completed, the assembly can be bolted together. Bolt holes can be back drilled into the inner channel liner and reamed to the proper dimensions

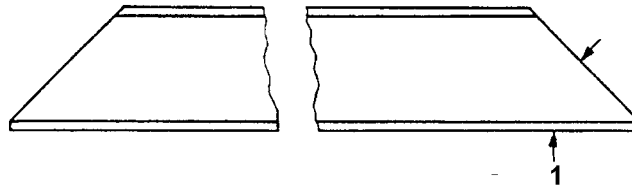

W9000296

Fig. 5 End Taper, Inner Channel Liner

1 45° Maximum Taper Each End

Fish Plates

Fish plates are large flat plates bolted to the web of the frame rail. They are usually 9 mm to 13 mm (3/8 in to 1/2 in) thick and increase the section modulus considerably. The height of the fish plate often exceeds that of the frame rail (see Fig. 6 Fish Plate Installed On Channel). Fish plates are often installed between the rear of the cab and the end of frame to handle the stresses imposed by a crane mounted directly behind the cab.

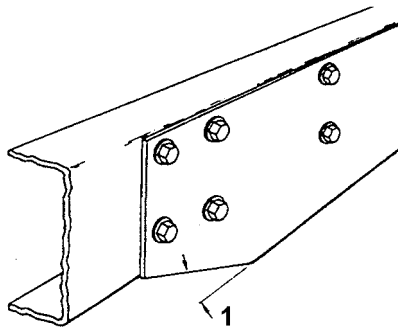

W9000297

Fig. 6 Fish Plate Installed On Channel

The ends of the fish plates should be tapered (as shown in Fig. 7 End Tapering, Fish Plates with 'L' Reinforcements) to reduce stress concentration in this area. Fish plates should be bolted using the match drilled technique so the fish plate and frame act as one. Rivets, brackets, and other components in the area where a fish plate is to be installed will have to be removed and reinstalled with the fish plate in place.

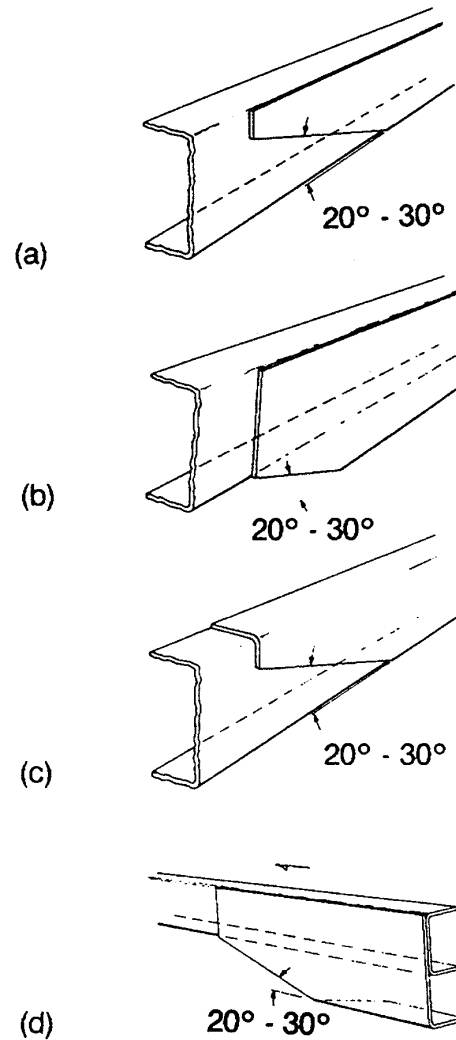

W9000298

Fig. 7 End Tapering, Fish Plates with 'L' Reinforcements

L-Shapes

L-shapes are used in similar applications as fish plates. The advantage of an L-shape is its flange which increases the section modulus considerably (see Fig. 8 "L" Reinforcement and Fig. 9 Inverted "L" Reinforcement Subframes). L-shape reinforcements are installed similarly to fish plates and the ends should also be tapered.

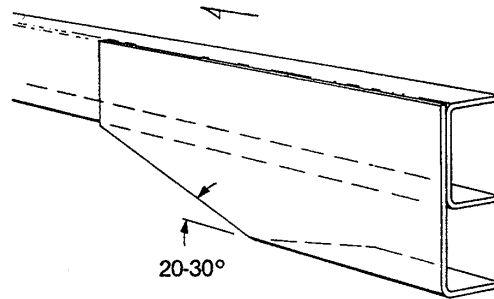

W9000299

Fig. 8 "L" Reinforcement

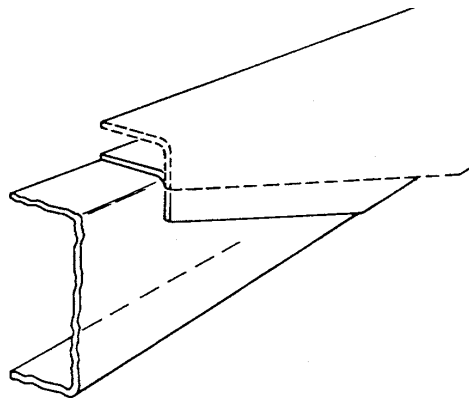

W9000300

Fig. 9 Inverted "L" Reinforcement Subframes

Notes

Subframes

A subframe is an additional frame mounted on top of the existing truck frame (see Fig. 10 Subframe Installation). Of all the types of reinforcements used, the subframe is the easiest to install. However, the subframe does add considerable weight to the vehicle and it raises the height of the body and equipment being installed.

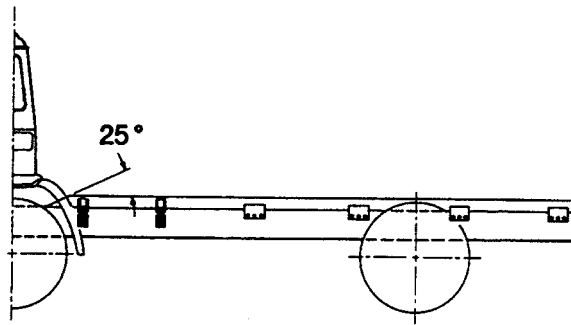

W9000301

Fig. 10 Subframe Installation

The subframe can be almost any shape, however the C-channel is the easiest shape to mount. The subframe usually extends from the rear edge of the cab back to the end of the frame. Except for the two front anchorages, subframes are rigidly attached to the truck frame by welding flat plates to the side of the subframe and bolting these plates to the web of the truck frame (see Fig. 11 Rigid Attachment).

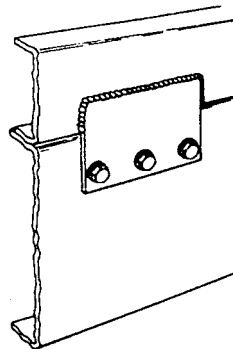

W9000302

Fig. 11 Rigid Attachment

The two front attachments should allow longitudinal movement between the chassis and subframe (see Fig. 12 Subframe Mounting Allowing Longitudinal Movement). U-bolts could also be used at the front.

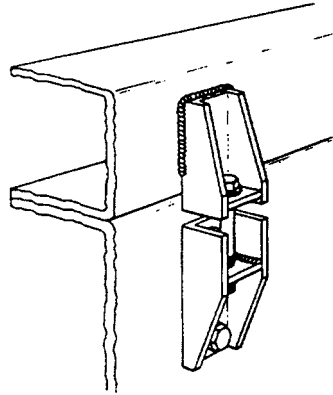

W9000303

Fig. 12 Subframe Mounting Allowing Longitudinal Movement

The flat mounting plate bolts (as shown in Fig. 11 on page 26) should be match drilled. This type of attachment causes the subframe to act as one piece with the truck frame and results in a dramatic increase in section modulus.

Note: This type of reinforcement should not be confused with the C-channel longitudinal member found in most van, platform and other bodies. These types of bodies are normally attached to the frame with U-bolts which allow the truck frame and body longitudinal member to act independently.

When cranes are mounted directly behind the cab, the rigid attaching plates shown (see in Fig. 11 on page 26) can be used the full length of the subframe.

Notes

The front end of the subframe should be tapered 25° (as shown in Fig. 13 End Tapering, Subframe) to reduce stress concentrations at the end and chamfered on the bottom leading edge to prevent chafing against the truck frame. An adequate number of crossmembers should also be installed in the subframe to prevent lateral movement.

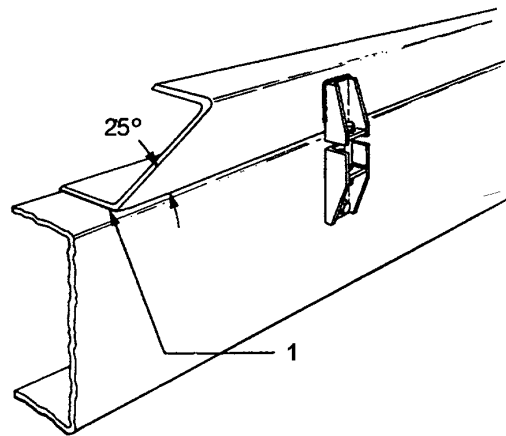

W9000304

Fig. 13 End Tapering, Subframe

1 Chamfer Bottom Edge of Subframe

Angle Reinforcements

Angle reinforcements are typically used when two sections of frame rail are joined together. They are not usually considered to be a reinforcement, but rather serve to reduce the stress in the joint where the two pieces of frame are joined.

Reinforcing angles can be made from 0.25 inch-thick steel plate bent 90° to form an angle. The bend radius should be large enough so that the angle does not rub against the inside corner of the frame rail. Both ends of the reinforcing angles must be tapered with angles of 20 – 30°. The reinforcing angles are welded in place over the frame splice. Care must be taken to ensure that the welds on the flanges are 0.20 inch minimum from the edge of the flanges.

Notes

Minimizing Frame Failure

Generally, frame failures can be minimized or eliminated by reducing concentration of stress in small areas of the frame:

- 1 Use vehicles only for those purposes for which they were designed.
- 2 Follow recommended practices when mounting a body or equipment on a frame.
 - Avoid abrupt changes in section modulus — for example, heating the frame
 - Do not drill holes in the frame rail flanges.
 - Space holes in the web section of a rail at least 50 mm (2 in) apart.
 - Use existing holes whenever possible.
 - New holes should be drilled as close as possible to the neutral axis of the web (halfway between the flanges) or on the same horizontal line as adjacent holes.
 - Do not cut holes with a torch.
 - Do not cut notches in the rails.
 - Do not heat steel frame rails.
 - Avoid welding on the rails.
 - No more than four holes should exist on the same vertical line of the frame webface.
 - Any holes drilled in a reinforcement should be spaced a distance equal to at least two times the thickness of the material being installed as measured from the edge of the reinforcement to the side of the hole being drilled.

Bolted Attachments

All body and equipment mounting brackets should be bolted to the truck frame web area. Use SAE Grade 8 bolts 3/8" and larger. Hardened flat washers or flanged head nuts and bolts should be used on both sides. Holes should be drilled or reamed out and the diameter should not be more than 1/32" oversized (see Fig. 14 Normal Bolted Attachment).

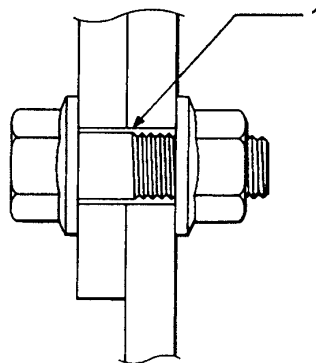

W9000292

Fig. 14 Normal Bolted Attachment

Mountings where alignment is critical or where high loads and stresses develop should utilize matched drilled bolting techniques.

Matched drilled bolting requires the use of shoulder bolts which are driven through slightly undersized mounting holes. The shank of the bolt should be long enough to penetrate both parts being joined. This technique assures good alignment of the mating parts and eliminates working between the mating parts if the bolts should loosen. The same grade and type of fasteners specified above are recommended for matched drilled bolting (see Fig. 15 Matched Drilled Bolted Attachment).

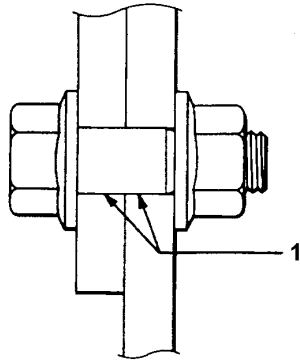

W9000293

Fig. 15 Matched Drilled Bolted Attachment

NEVER use a torch to cut out mounting holes. Caution should be taken to assure that air and electrical lines are protected when drilling. Mounting holes are not to be drilled in the upper or lower flanges of the frame rail except at the very end of the frame rail. Holes drilled in the frame may not exceed 21/32" in diameter. Fig. 16 Minimum Spacing shows the minimum spacing allowed between bolt holes and the flanges of the frame.

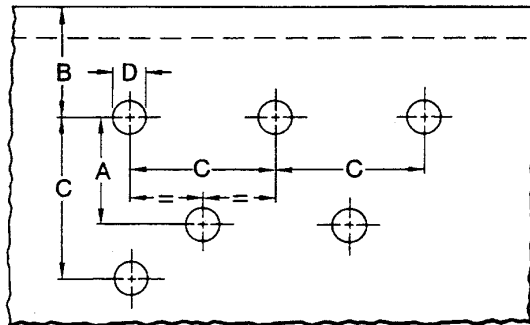

W9000294

Fig. 16 Minimum Spacing

- A = Min. 3 x D
- B = Min. 3 x D, min. 2.25 i
- C = Min. 4 x D
- D = 0.66 in max.

Welded Attachments

With one exception, welding of bodies, equipment or mounting brackets to the truck frame is strictly forbidden. The exception is that the rear hinge of a dump body or tilting flatbed body may be welded in place provided it is located at the very end of the frame and that the welding does not occur within 100 mm (4 in) of the edge of the rearmost spring hanger bracket.

When welding, care must always be taken to protect the electrical components of the vehicle. First, disconnect the negative battery cable. Then disconnect all cables from the alternator. Air and electrical lines must also be protected from damage during the welding process.

The negative or ground cable of the welding machine must be connected properly to the section of the vehicle under modification and should be as close as possible to this area. Connection of the ground cable to parts of the vehicle that will bring components, including bearings, into the welding circuit may result in damage to these components.

When welding on the truck frame is required, the following welding specifications are recommended:

DC-Welding Electrode ESAB OD 48.00
 Phillips PH 35, ASEA Z4 or equivalent
 Arc Voltage 18–24 V, DC + Pole

AC-Welding Electrode ESAB OK 48.15
 Phillips PH 36, ASEA Z22 or equivalent
 Arc Voltage 20–26 V; AC Minimum Idle Voltage on AC Current: 65 V

Note: The welding data refers to an OK 48.15 electrode. Consult information supplied by other manufacturers for different electrodes.

MIG-Welding Filler Material: 125 1 0 1.0
 Gas: SK 203 CO + Argon, 80% Argon; 10 liters/min.

Notes

Welding and Drilling

- 1 DO NOT drill frame side rail upper or lower flanges.
- 2 DO NOT weld steel side rails.



CAUTION

Heating the suspension components and frame rail may weaken them. Hot surfaces can also cause serious burns.

- 3 When welding is performed anywhere on the vehicle, precautionary measures should be taken to prevent damage to electrical system wiring or components. Prior to welding, any parts which would be damaged by excessive temperatures should be removed or adequately shielded. Also prior to welding, the battery cables should be disconnected at the battery.



CAUTION

Welding on trucks can damage the vehicle electrical system/components due to the voltage and current spikes that normally occur when welding. It is preferable to avoid welding on an assembled truck. However, if any structure on or in contact with the vehicle must be welded, follow the recommendations below:

- Before welding on the vehicle, disconnect power to the component being welded.
 - Disconnect both the positive (+) and negative (-) battery cables. Disconnect the negative cable first. Reconnect the positive cable first. Vehicles equipped with battery “quick disconnect” must still have the cables removed directly at the battery.
 - Disconnect engine/starter ground from the chassis. This connection is located outside the left-hand frame rail in the engine compartment. Disconnect the power harness and vehicle interface harness at the engine Electronic Control Unit (ECU).
 - If vehicles are equipped with systems that have their own Electronic Control Units (ECUs), such as ABS brakes, Vehicle ECU, or instrument cluster disconnect each control unit at each electrical connection. This “opens” the circuit and will prevent transient voltage from reaching one ECU to another.
 - Attach the welder ground cable as close to the weld as possible (no more than 2 feet from the part being welded).
 - Do not connect the welder ground cable to the engine ECU or the ECU cooling plate.
 - Welding cables should not be allowed to lay on/near or cross over any electrical wiring or electronic component during the welding procedure.
 - After the welding process has been completed and the welded parts have cooled, inspect wiring and components for possible shorts or damage which would allow the possibility of drawing excessive currents or cause short circuits when the batteries are reconnected.
- 4 Holes to mount brackets, out-riggers and supports, may be drilled in the vertical side rail web with the following restriction:
 - Material between edge of hole and inside of upper or lower flange must not be less than 51 mm (2.00 in.).
 - The minimum edge distance between any two holes up to 5/8 in. diameter must be 25 mm (1.0 in.). The minimum edge distance must be 1.5 times the diameter of the largest hole.
 - No holes are allowed with a diameter greater than 19 mm (0.75 in.).
 - Avoid close vertical succession of fasteners.
 - All attaching fasteners, including flat washers, must be of high strength steel (Grade 8).

- 5 The frame and wheelbase should not be lengthened or shortened without the prior written approval of VTNA Engineering. Any deviation from the original vehicle specification will become the responsibility of the subsequent stage manufacturer or installer.

Frame Rails and Crossmembers

The frame for the VN/VHD series has frame side member designs for vehicles produced by Volvo Trucks North America. The designs include two side member heights, three side member thicknesses, and a flared shape.

The frame height is constant for the entire length of the rail. The rail height is either 266 mm, called the Low Profile frame, or 300 mm, called the High Profile frame. The low profile frame may have a thickness of either 6 mm, 7 mm, 8 mm or 11.1 mm. The high profile height frame may have a thickness of 7 mm, 8 mm or 11.1 mm (VHD). The rails of the frame are separated at the front edge a distance of 1080 mm (outside edges). From a position just rearward of the front engine crossmember to a position just forward of the rear engine crossmember the rails are tapered closer together. From that point to the rear edge, the distance is 836 mm (inside edges).

Note: Frame dimensions are specified in millimeters due to design. To obtain the approximate dimension in inches, multiply mm by 0.03937.

Because the frame rails are made of a high strength heat-treated steel, only the frame modifications detailed in this information are permitted, in order to ensure that the structural integrity of the rails is maintained.

In conjunction with the new frame design, the allowable bolt hole patterns in the frame web are specified and must be strictly followed.

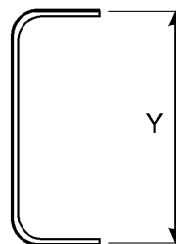
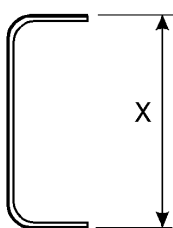
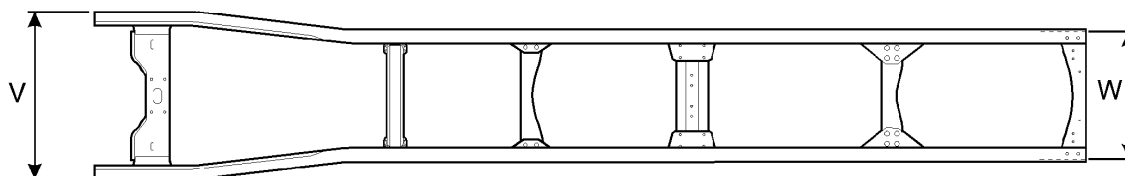

W7001181

V 1080 mm (42.5 in)

W 836 mm (32.9 in)

X 266 mm (10.48 in)

Y 300 mm (11.82 in)

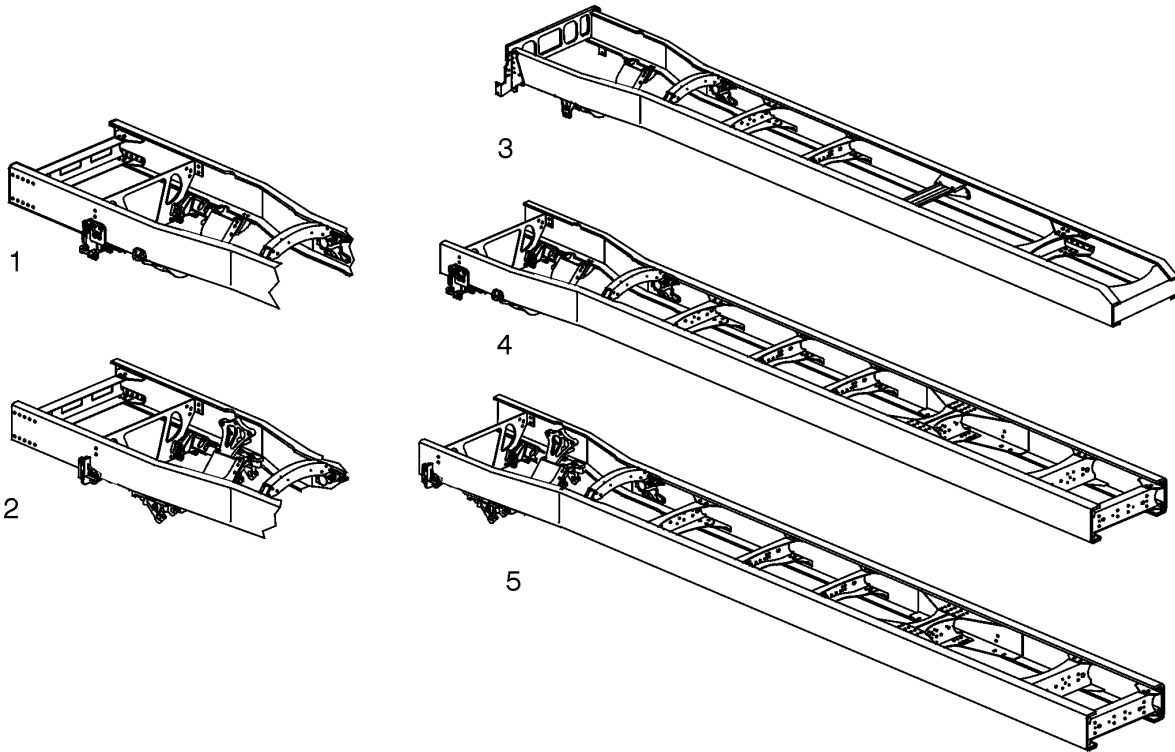

W7001180

VN/VHD Frame rails with crossmembers:

- 1 Axle Forward with extension (VHD)
- 2 Axle Back with extension (VHD)
- 3 VN
- 4 Axle Forward (VHD)
- 5 Axle Back (VHD)

The frame consists of two steel side rails joined by several crossmembers. The frame for the VN/VHD series models is made in a variety of configurations to allow flexibility in adapting the frame for different transport requirements.

See the following design information:

- “Side Members”, page 34
- “Crossmembers”, page 37
- “Mounting Hardware and Brackets”, page 43
- “Fasteners”, page 43

Side Members

The side members, or frame rails, are constructed of 760 MPA (110,000 psi) yield heat treated steel. There are several combinations of side member height and thicknesses. The smaller height, referred to as the Low Profile frame, has a web height of 266 mm, and may be either 6 mm, 7 mm, 8 mm or 11.1 mm (VHD) thick. The larger height, referred to as the High Profile frame, has a height of 300 mm and may be either 7 mm or 8 mm thick.

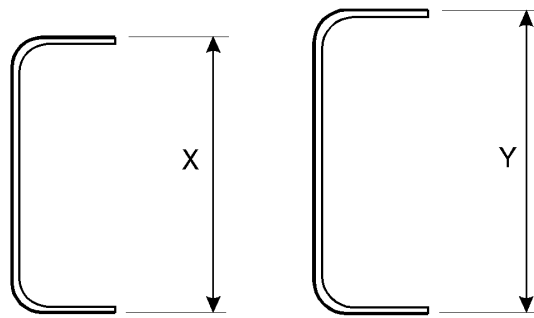

W7001182

X 266 mm (10.48 in)

Y 300 mm (11.82 in)

These combinations of height and thickness provide for the variety of load and usage characteristics necessary to meet the hauling requirements of nearly any tractor or truck. The flange width is a constant 90 mm for all combinations of web height and thickness.

Unlike previous frame designs, the side members are not an equal distance apart for their entire length. When viewed from the side, the side members appear straight. Viewed from above, the frame rails are flared outward from a point just forward of the rear engine crossmember. This design provides for increased lateral, vertical, and torsional stiffness. The result is improved vehicle integrity, handling, accident avoidance, and collision energy absorption. Widening the frame at the front also minimizes the need for cut outs in the frame flange to adapt the side members to various vendor engines.

Regardless of the frame rail height, thickness, and length, the basic frame design and dimensions are the same. The front rail separation is 1080 mm, as measured from the outside of the frame rails, because the front crossmember bolts to the outside of the rails. The separation at the rear end is 836 mm, as measured from the inside, because the closing crossmember is bolted between the rails. The separation is a constant 836 mm at a point 1635 mm from the front.

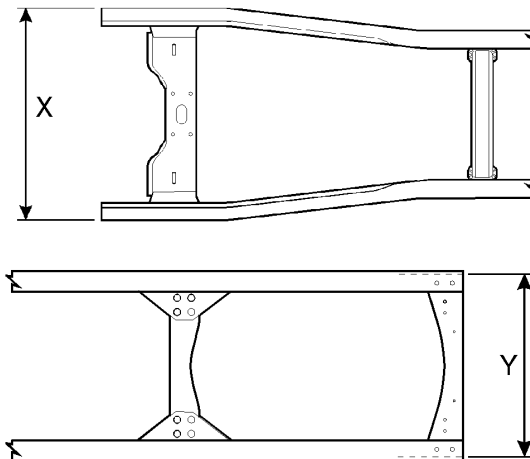

W7001183

X 1080 mm (42.5 in)

Y 836 mm (32.9 in)

A standard hole pattern is designated for the frame rail web. For vehicles with a complete Volvo T-Ride suspension, the hole pattern is 60 mm vertically between holes and 50 mm horizontally. These dimensions apply to the web behind the rear bend and forward of the rearmost suspension component for the rear axles. For vehicles with other than Volvo T-Ride suspension, the pattern is 60 mm vertically and 50 mm horizontally from behind the forward spring hanger to the intermediate crossmember, and 3 in vertically by 2 in horizontally from the front axle crossmember to the rearmost suspension component for the rear axles.

The rear end of the frame is either cut straight or is tapered at a 27 degree angle. There are three different closing crossmembers to accompany the style of frame termination.

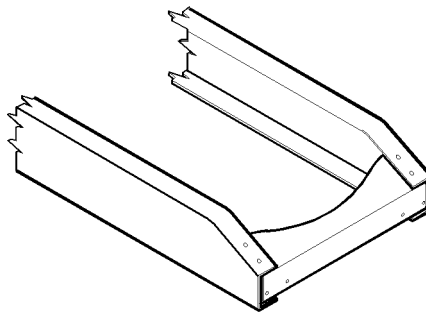

W7000378

Tapered frame end with tapered closing crossmember

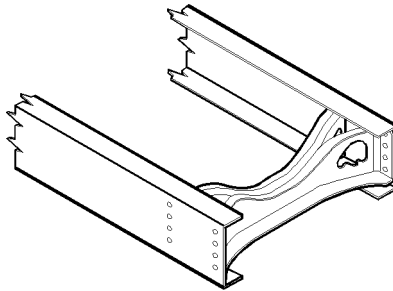

W7000379

Straight frame end with splay closing crossmember

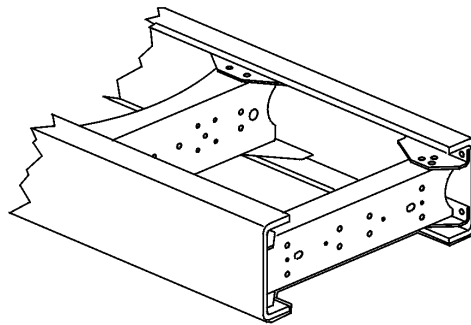

W7001005

VHD frame with closing crossmember

Crossmembers

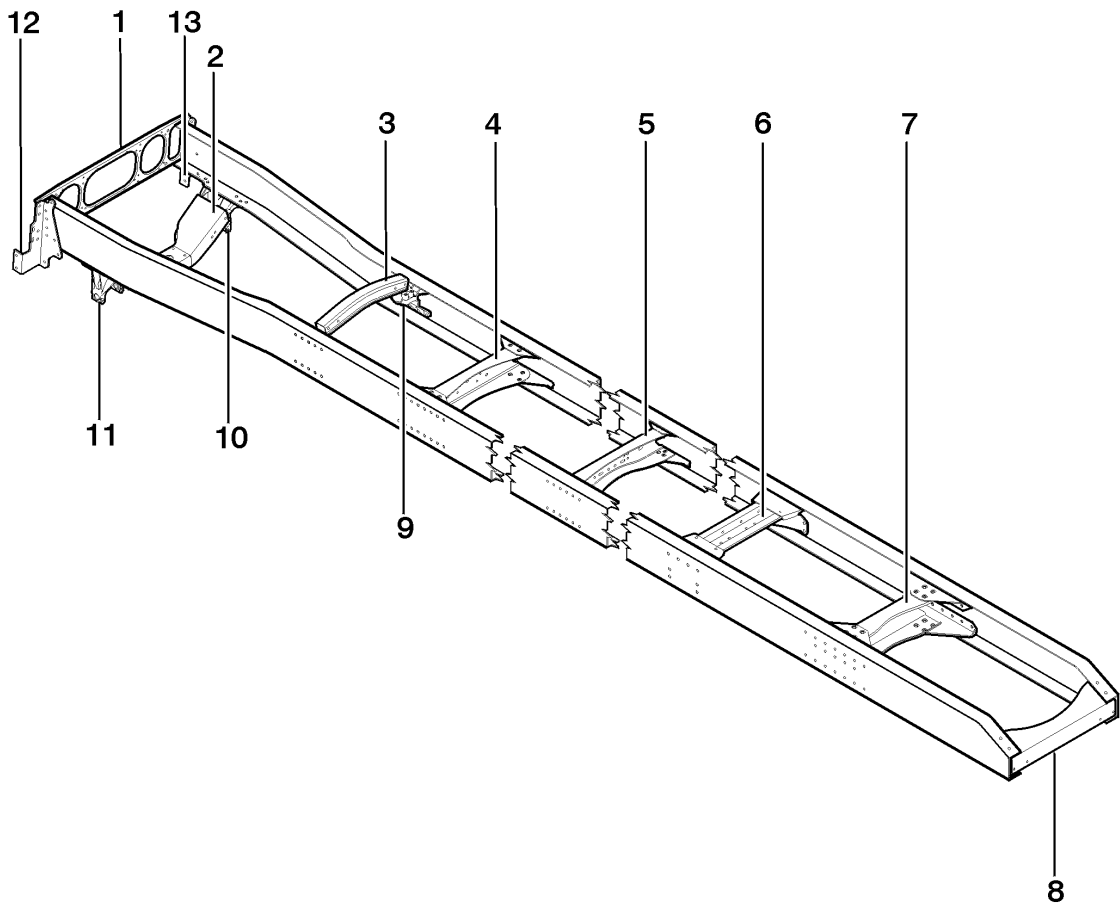

W7001043

VN Frame and Crossmember

- | | | | |
|---|---------------------------|--------|------------------------------|
| 1 | Front Crossmember | 7 | Rear Suspension Crossmembers |
| 2 | Front Engine Crossmember | 8 | Closing Crossmember |
| 3 | Rear Engine Crossmember | 9 | Rear Engine Support Brackets |
| 4 | Transmission Crossmember | 10, 11 | Front Spring Hanger |
| 5 | Intermediate Crossmember | 12, 13 | Bumper Mounting Bracket |
| 6 | Front-of-Axle Crossmember | | |

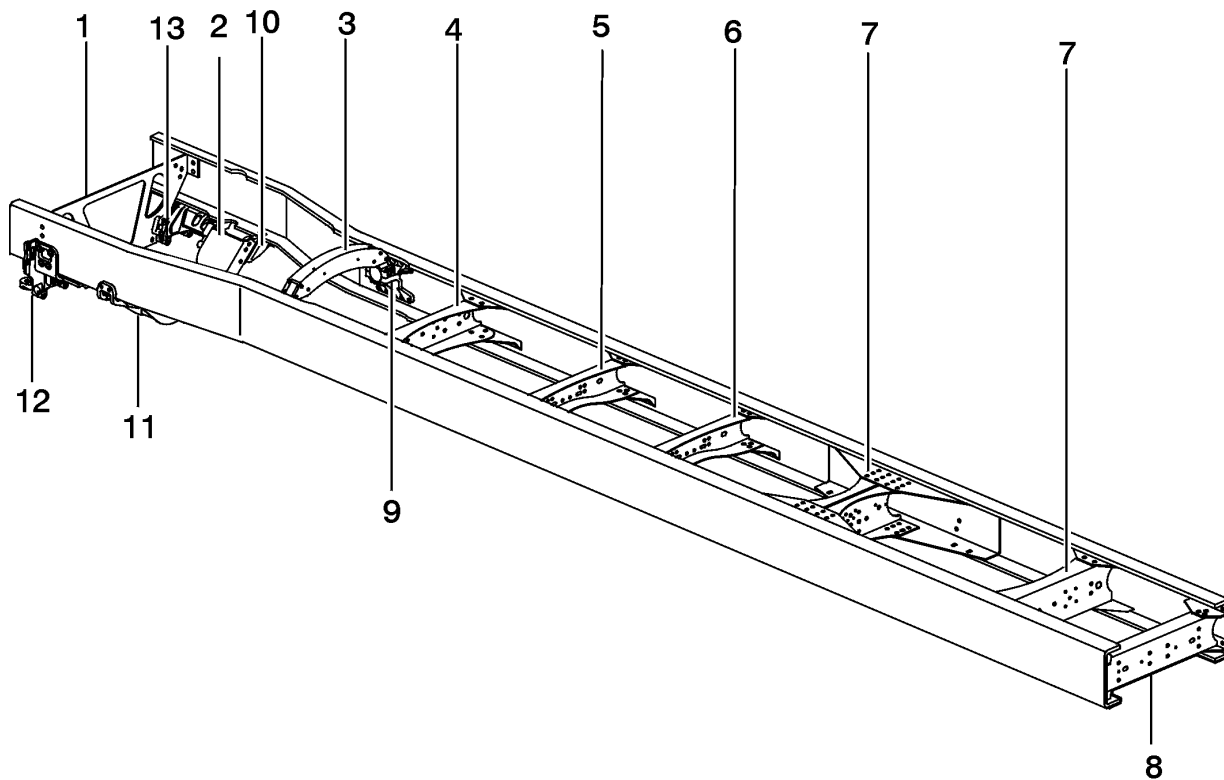

W7001008

VHD Frame and Crossmember

1	Front Crossmember	7	Rear Suspension Crossmembers
2	Front Engine Crossmember	8	Closing Crossmember
3	Rear Engine Crossmember	9	Rear Engine Support Brackets
4	Transmission Crossmember	10, 11	Front Spring Hanger
5	Intermediate Crossmember	12, 13	Bumper Mounting Bracket
6	Front-of-Axle Crossmember		

The crossmembers provide a high degree of torsional stiffness to the frame. They allow the vehicle to handle the side forces caused by turns and uneven road conditions. Improved crossmember design and positioning for the VN/VHD series models has resulted in reduced weight, enhanced frame stability, improved truck handling, and reduced noise and vibration.

The crossmember components are to be treated as a unit. Each consists of a beam and end plates. Where beams and end plates are riveted together, they must not be separated. If replacement is necessary, the replacement beams must be cut in the center and welded together after the end plates have been mounted to the frame rails. The front engine crossmember is an exception to this, in which case, the rivets are replaced by body bound bolts.

Note: The numbers in the crossmember descriptions that follow refer to the numbers on the frame and crossmember diagram at the beginning of the Crossmembers subsection.

Front Crossmember

The front crossmember connects the front ends of the side rails. It is 4 mm thick and has large holes to allow maximum air flow to the radiator and charge air cooler. It is physically bolted to the front crossmember and bumper mounting brackets, which are bolted to the side rails.

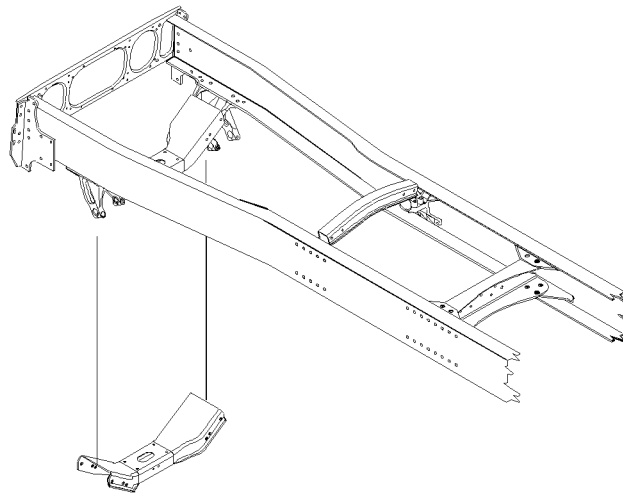

W7000376

VN

Front Engine Crossmember

The second crossmember is the front engine crossmember. It is riveted to the front spring hangers, which are bolted to the side members. It is designed to support the forward end of the front suspension and the front engine mount, which is a single point suspension at the center of the crossmember. The crossmember is universal in that it can accommodate engines made by VOLVO or by other manufacturers. This crossmember is simply rotated 180° from the VOLVO engine position to adapt to other vendor engines.

Unique brackets have been designed for fitting each vendor engine to the VN/VHD series engine mounts. Because the second crossmember coincides with the spring hangers, it provides support against side-bending forces generated by driving in curves.

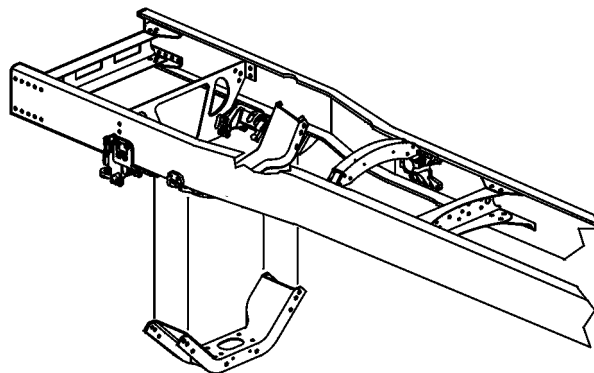

W0001879

VHD

Rear Engine Crossmember

The next crossmember is the rear engine crossmember. It is supported by the rear engine support brackets and provides support against side loads that occur during vehicle turning. This crossmember is attached to the rear engine mounting brackets. If the vehicle is equipped with a VOLVO transmission, the brackets are bolted to the engine flywheel housing. For vendor transmissions, the brackets are bolted to the clutch housing.

Transmission Crossmember

The transmission crossmember is the first crossmember rear of the transmission. The stiffness of this crossmember is improved over earlier models due to wider end-plate attachment flanges. Its higher placement on the frame provides greater structural strength. It is positioned so that there is sufficient prop-shaft clearance without having to bend the crossmember.

The rivets that connect the beam to the end plates on this crossmember are covered by the frame flange and are not accessible.

Intermediate Crossmember

The intermediate crossmember functions as the anchorage for the driveshaft center bearing mounting in addition to its normal function. Longer wheelbase vehicles may have one or two additional intermediate crossmembers installed.

Note: Removal of the transmission and intermediate crossmembers requires cutting the old crossmember in half and unbolting the end plates from the frame. Installation requires cutting the new crossmember in half, bolting the halves in place, and welding them together.



CAUTION

Possible material failure. The quality of the weld on a replacement crossmember is important to the structural strength of the crossmember. All crossmember welding must be performed by a certified welder to guarantee the integrity of the crossmember. Failure to properly perform the weld could result in failure of the crossmember.

Front-of-Axle Crossmember

The front-of-axle crossmember exists mainly to provide support for the suspension system. This particular crossmember is used on vehicles equipped with the VOLVO Optimized Air Suspension (VOAS) and the four-spring leaf spring suspension. An aluminum front axle crossmember is available for reduced weight.

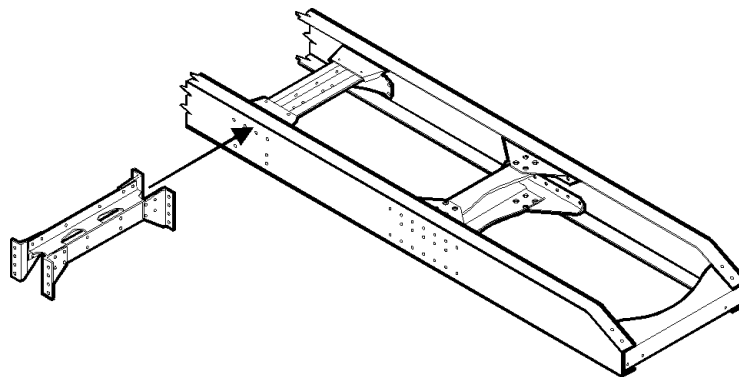

W7000374

Rear Suspension Crossmember

There are a variety of rear suspension crossmembers designed to accompany the axle suspension systems they support. Because of the higher stresses and loading taken up at the rear suspension, this crossmember has larger flanges than the other crossmembers.

The rear suspension crossmembers shown at right are for 4 x 2 with air or mechanical suspension, 6x4 tractor with parabolic leaf springs or VOLVO Optimized Air Suspension (middle), 6 x 4 with Haulmaax and 6 x 4 rigid with T-Ride (bottom).

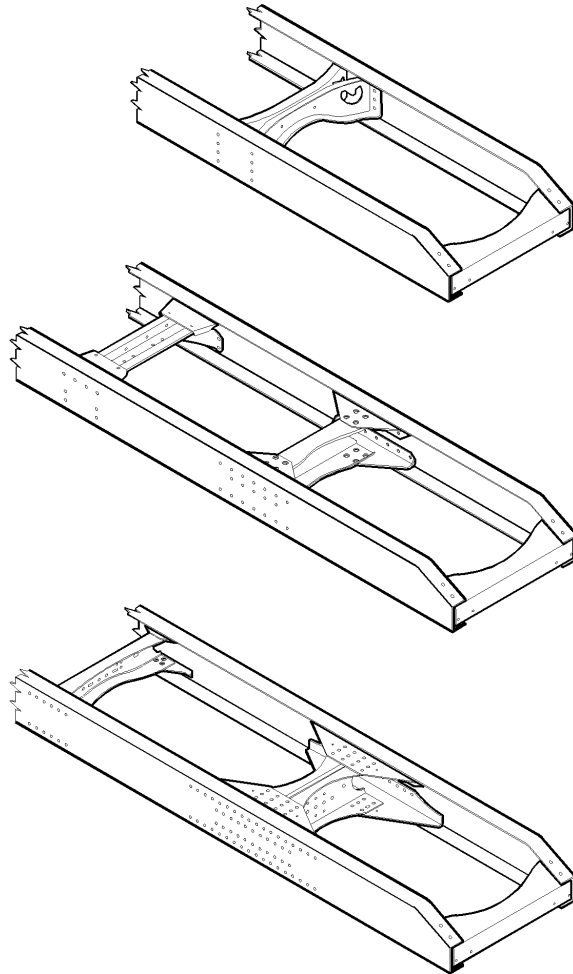

W7000419

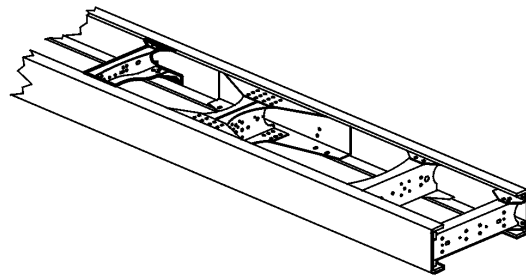

W0001880

Closing Crossmember

The closing crossmember keeps the separation of the frame rail ends fixed at 836 mm. The frame rail ends are either tapered at a 27 degree angle, or are cut straight. There is a crossmember designed for each of these conditions.

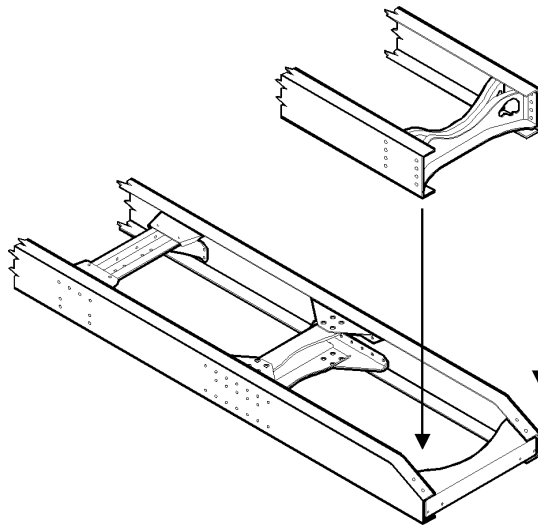

W7000375

Closing Crossmember

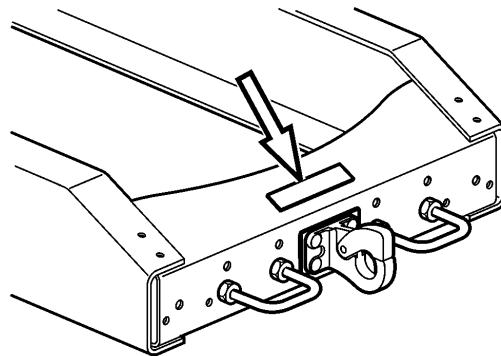

W7001269

Closing Crossmember with Tow Hook

Mounting Hardware and Brackets

The engine mounting system consists of brackets constructed of ductile iron castings and rubber cushion isolators. With VOLVO transmissions, the rear mount attaches to the engine flywheel housing. The rear mounts attach to the clutch housing on all vendor transmissions.

Various brackets have been designed to adapt the VOLVO engine front isolators and cushions to vendor engines. The rubber cushions on the engine mounts are tuned to a precise vertical, longitudinal, and lateral stiffness. The fine tuning of the mount cushions enhances truck performance by isolating engine vibrations and noise from the chassis cab. These cushions have the ability to dampen forces caused by frame distortion when driving off road or on poor roads. The front and rear cushions are designed differently to allow a higher degree of movement.

The engine mounts minimize the motion of the engine. In addition, they provide for easy service to the engine. These advantages apply to all of the engines available with the VN/VHD series models.

The fuel tank mountings are J-brackets that support and attach the fuel tank(s) to the chassis. Dual fuel tanks are stabilized by an additional crossover brace. They also support the steps up to the cab.

Bolts, Flange Bolts, Rivets, Huck Bolts

VHD Model:	
Component	Mountings
Fifth Wheel HAS 460 Suspension Brackets only (3 per side) 4x2 Spring Suspension Brackets (2 per side)	Huck Bolts
T Ride Suspension (52 K and higher)	Rivets
B Ride Suspension (46 K and lower)	Flange Bolts
RT Suspension	Standard Type Bolts
HN Suspension	Dog Point Bolts
Note: Dog point bolts are used on 90% of VHD Frame components	

Fasteners

The crossmembers are connected to the frame rails using metric flange bolts. The beams and end plates of individual crossmembers are either bolted to one another using metric flange bolts, or are riveted. Whenever replacement of metric flange bolts is necessary, they must be replaced with identical hardware. In cases where rivets are used to connect beams and end plates, they must not be disturbed because this will affect the structural integrity of the crossmember.

Some crossmember beams are riveted to the end plates. In cases where the rivets are accessible and must be removed, they should be replaced with a 16 mm body bound bolt. These special bolts are manufactured with a shank diameter that is slightly larger than the outer diameter of the thread so that the load is not placed on the threaded portion of the bolts.

To make proper use of body bound bolts, the holes that will be used must be reamed to a diameter of 0.79 mm (0.031 in) larger than the thread diameter. Proper joining of the crossmember and end plates or brackets is accomplished when the shank of the body bound bolt is in complete contact with the crossmember and inserts at least 2/3 of the way into the hole in the component on the nut side but does not extend out of the hole.

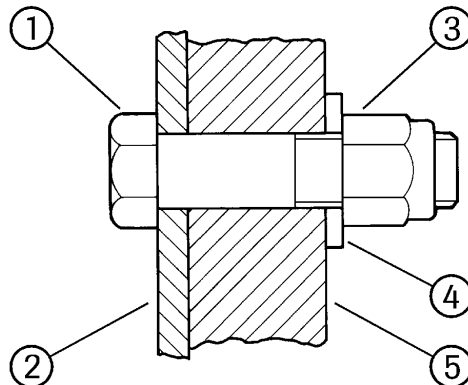

W7000383

- 1 Body bound bolt
- 2 Crossmember
- 3 Elastic stop nut
- 4 Hardened flat washer
- 5 End plate or spring bracket

Some components are fastened to the frame using HUCK® Spin fasteners. If these fasteners must be replaced, metric flange bolts of the same size should be used.

Huck fasteners can usually be removed by using an air impact wrench.

For further information on Huck fasteners refer to

http://www.arconic.com/global/en/products/product.asp?bus_id=1&cg_id=77&cat_id=1443&prod_id=900.



CAUTION

Possible component damage. Never mix HUCK® Spin fasteners and flange fasteners within a hole pattern. Mixing fastener types could cause the flange bolts to come loose.

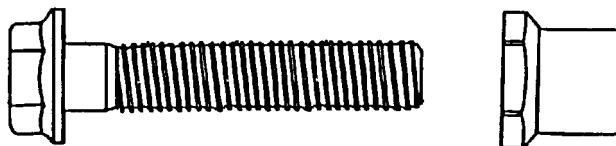

W7000440

HUCK® Spin bolt and Collar

Specifications

Rear Towing Configurations

Towing Pintle

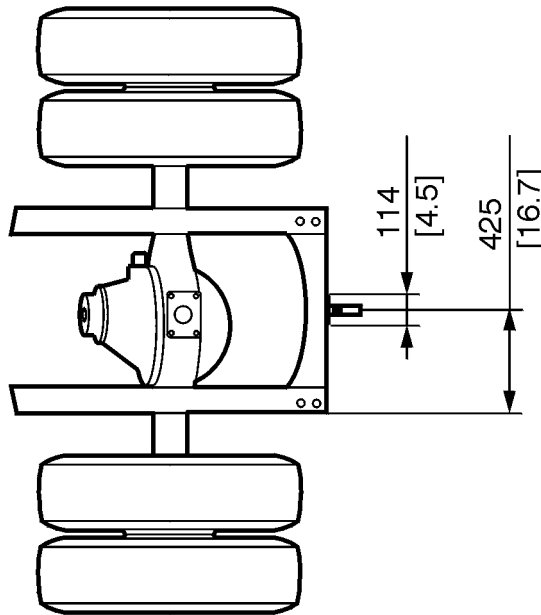
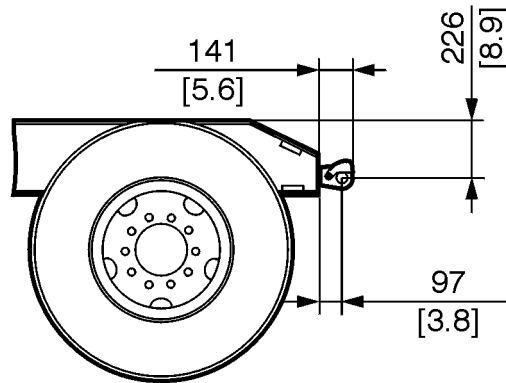

Towing Pintle, Tapered Rear Frame End

Pintle Hook Dimensions

Rigid

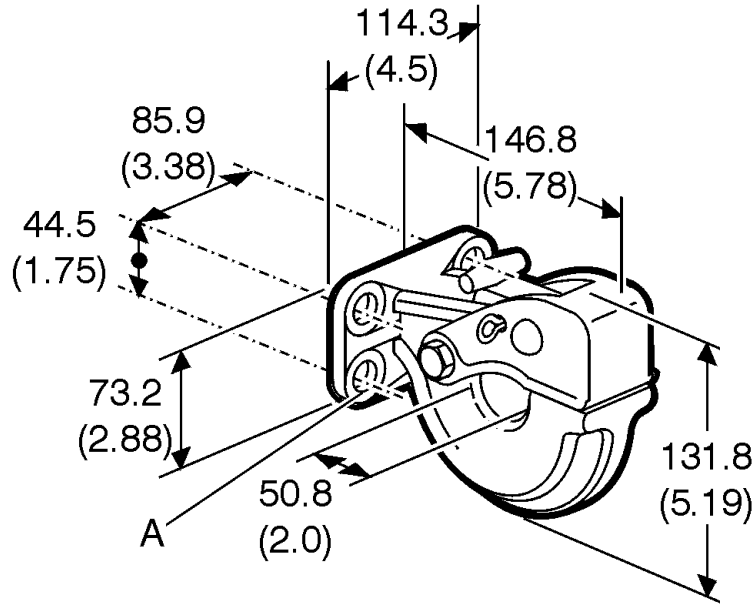

PH-5 Rigid Pintle Hook

- 1 **Diameter:** 13.2 mm (0.52 in) through; 4 required.
- 2 **Capacity:** 907 kg (2,000 lb) Maximum Vertical Load, 1 814 kg (4,000 lb) Maximum Gross Trailer Weight
- 3 **SAE J847 Information:** Type I - Not applicable. Type II - 3 629 kg (8,000 lb)
- 4 **Description:** Rigid pintle hook. Weight 3 kg (7 lb)
- 5 **Drawbar Eye Dimensions:** 50 mm (2 in) to 76 mm (3 in) I.D. with 31.75 mm (1.25 in) to 41.14 mm (1.62 in) diameter section.

Notes

Tow Hooks

Available on the VHD only.

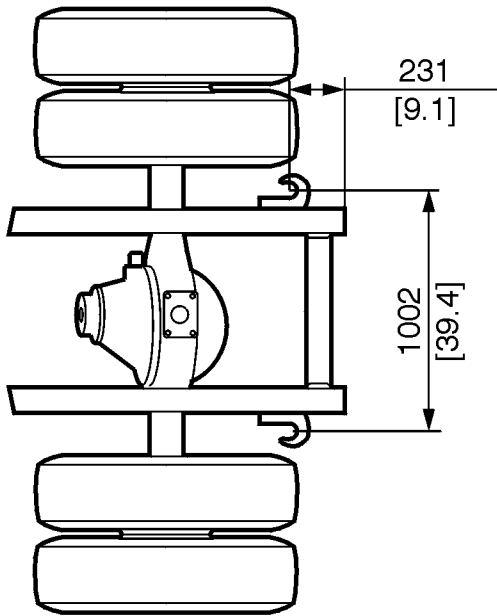
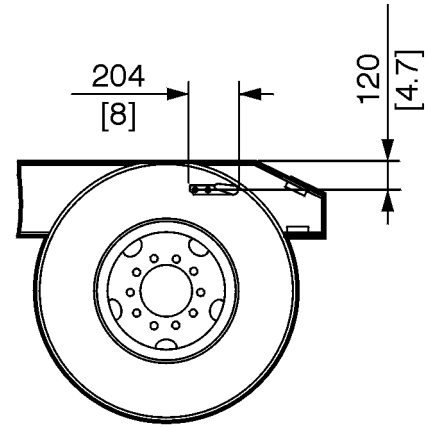
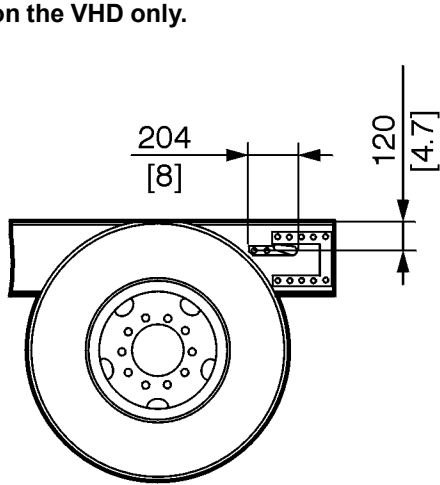

Tow Hooks, Standard Rear Frame End

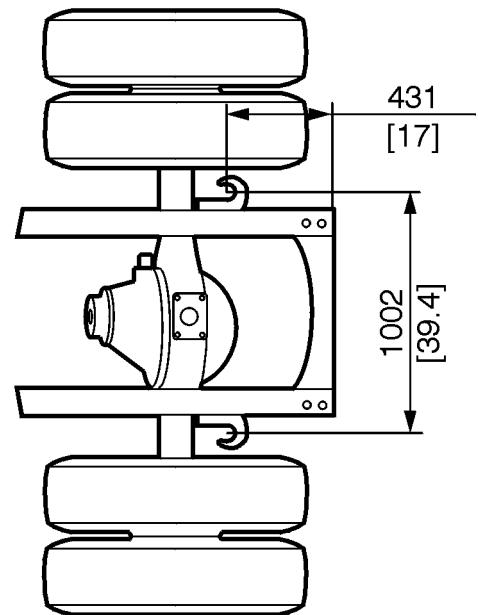

Tow Hooks, Tapered Rear Frame End

Towing Procedure

Note: For towing procedures for vehicles equipped with the Hendrickson Airtek front suspension, refer to the appropriate Hendrickson Service Literature.

General

CAUTION

The driveshaft must be removed before towing the vehicle. Failure to remove the driveshaft may result in damage to the transmission.

Towing Information, General:

Remove the driveshaft from the rear axle before moving the vehicle, unless it only needs to be moved a small distance for safety reasons. When the transmission is driven from the rear wheels without the engine running, there is no lubrication in the transmission.

Axle shafts must be removed if the vehicle is to be towed at speeds over 40 km/h (25 mph) or for a long distance. Openings should be covered to prevent loss of oil and entry of dirt and grit. Where oil-lubricated bearings are used, openings should be thoroughly sealed with metal discs and new gaskets before towing.

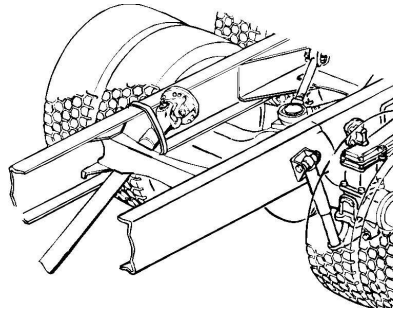

T0006670

WARNING

If a vehicle with air suspension is lifted by the rear frame member, there is a risk that the air springs will separate from the spring plates. When towing has been completed, DO NOT under any circumstances use your hands to reposition the air springs. There is a great risk that your hand will be caught between spring and plate causing personal injury.

WARNING

DO NOT tow a vehicle backwards when equipped with roof air fairings. The fairings act as an air scoop and may break off. Failure to follow this warning may lead to personal injury and vehicle damage.

WARNING

Vehicles with air fairings are tall. Make sure that the total height of the vehicle, when it is raised up behind the wrecker, does not exceed the maximum allowed height for local underpasses. Failure to follow this instruction may lead to personal injury and vehicle damage.

The vehicle may now be towed. It is recommended that a wrecker with a lift bar is used since the service brakes will not function. The system must be filled with air to release the parking brake or follow the mechanical spring brake caging procedures on “Caging Spring Brake Chambers”, page 51 .

Note: The power steering does not function when towing a vehicle with a disabled engine.

Towing Instructions



CAUTION

If the vehicle becomes disabled, it is very important to tow it properly. Failure to do so can cause damage to the frame and body parts. Follow the instructions below to avoid damage.

Towing Procedures: In the event that the vehicle cannot be reached to place the wrecker lift bar under the front axle, use the tow eyes supplied with the vehicle. The front tow eyes are used as a point at the front of the vehicle where the vehicle can be pulled.



DANGER

DO NOT use the tow eyes for raising the front of the vehicle; the tow eyes can break. DO NOT crawl under a vehicle suspended by tow eyes. Failure to follow these instructions can result in serious personal injury or death.

On day cab models, the tow eyes are stored bolted to the back of the cab wall.

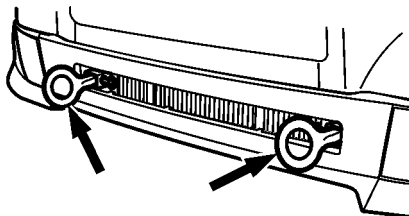

W8003187

On sleeper cab models, the tow eyes are stored bolted to the back wall of the luggage compartment wall.

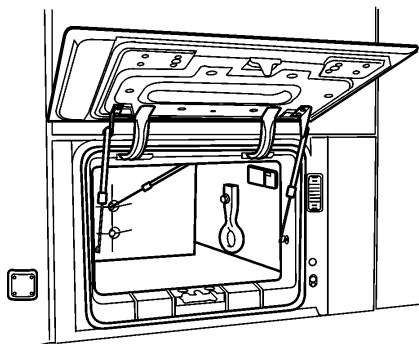

W8003124

The tow eyes are held in place when mounted on the front of the vehicle by tractor pins. These pins are stored in the tow eye mounting holes when not being used.



CAUTION

If the vehicle has the optional Rock guardrock guard installed, insert the lock pin into the tow hook from the opposite side during installation.

Rock/Stone Guard: In the new model VN trucks **if the truck has the optional** rock/stone guard installed, then the driver will have to insert the lock pin into the tow hook from the opposite side during installation.

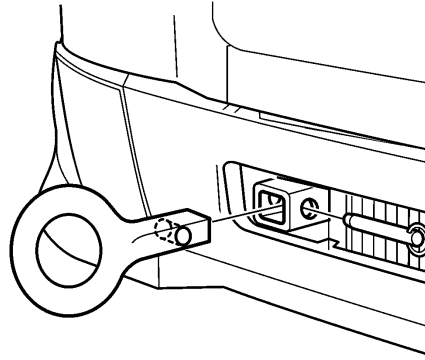

W8003186

When the vehicle is located properly, lift the front and locate the lift bar under the front axle and secure. Using the front axle for towing minimizes the possibility for damage to the vehicle body, frame and suspension.

Note: When the drive shaft or axle shafts are reinstalled, make sure the nuts are tightened to the correct torques. Also make sure the axle shafts are installed in the proper sides, with the left shaft in the left side and the right shaft in the right side.

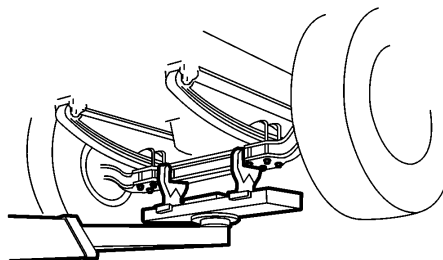

W9000588

Towing Pintle

Note: If your vehicle is equipped with a pintle hook system installed by Volvo Trucks North America, please note that the entire pintle hook system – including the frame and attachment to the frame – is rated at a maximum capacity of 1,814 kg (4,000 lb).

DANGER

DO NOT exceed the maximum towing capacity of the pintle hook system 1,814 kg (4,000 lb). Exceeding the maximum towing capacity may result in vehicle accident, serious injury or death.

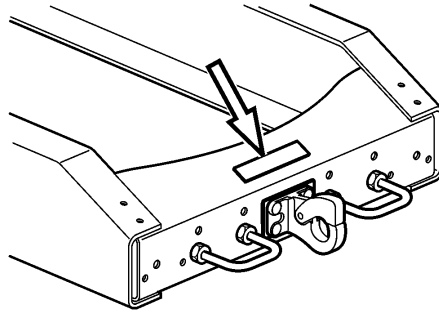

W7001269

Arrow shows Pintle Hook Advisory Label

Caging Spring Brake Chambers

The Spring Brake Chambers, may be released mechanically by caging the springs, if there is no compressed air available.

DANGER

Always start by chocking the wheels to prevent the vehicle from rolling. Failure to do so can result in unexpected vehicle movement and serious personal injury or death can occur.

Remove the plastic plug in the front end of the chamber. Remove the screw from the holder in the side of the brake chamber. Insert the screw into the front hole and push in until it bottoms. Screw into the cylinder so at least four to six threads have entered.

Install the washer and nut. Tighten the nut. This compresses the brake chamber spring and releases the parking brake.

⚠ DANGER

DO NOT attempt in any way to disassemble or tamper with the spring brake chamber. If the force stored on the spring is suddenly released, it can cause serious personal injury or death.

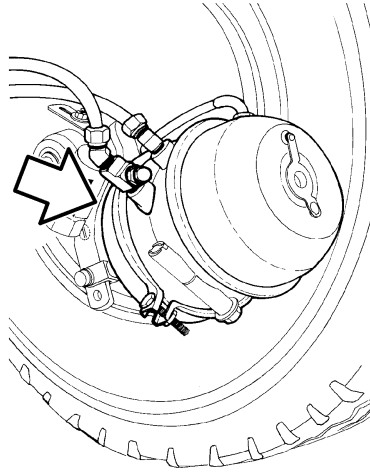

W5001430

Notes

Special Tools

For special tool ordering instructions, contact your local dealer.

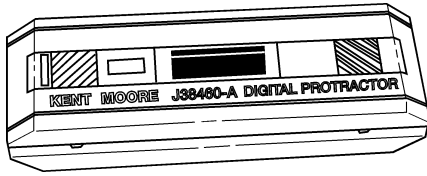

W7000708

J-38460-A Digital Protractor

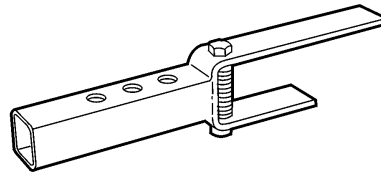

W7001140

J-44771 Frame Rail Guide Support

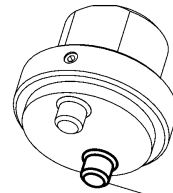

9809722

9996791

W7057090

9996791 Pin Tool

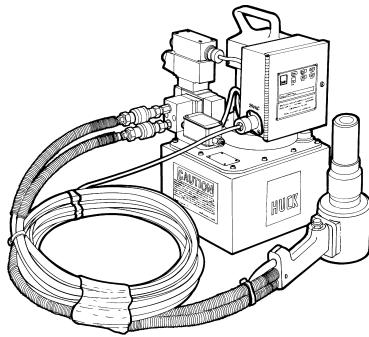

W0000397

HUCK® Manufacturing 940INTRKTV

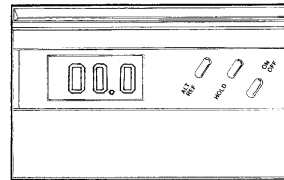

W0001875

Digital Angle Gauge

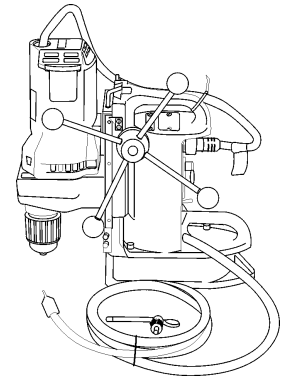

W0001876

Drill with Magnetic base

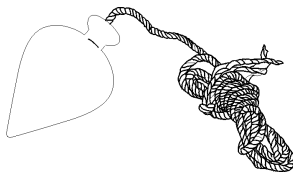

W0001877

Plum Bob

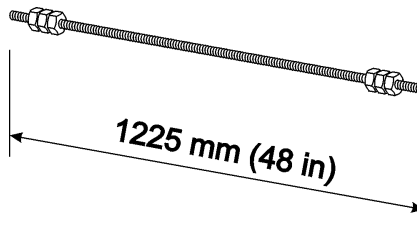

W0001878

Threaded rods

Frame Rail, Replacement

Removal

- 1 Park the vehicle on a level surface with transmission in neutral and the front wheels chocked. Raise the hood.
- 2 Remove the mounting screws from the top and bottom of the bumper.
- 3 Remove the support rods from the left and right sides of the bumper and remove the bumper.
- 4 Disconnect the headlamp and foglamp connectors and remove the hood spring.
- 5 Remove the hood splash shields on the left and right sides of the hood. Disconnect the hood restraint cylinders.
- 6 Remove the fasteners to the hood pivot and remove the hood.

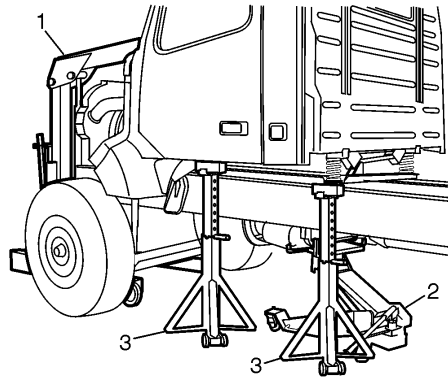

W7001177

- 1 Hoist
- 2 Transmission Jack
- 3 Jack Stand

- 7 Support the engine and transmission with a hoist and transmission jack.
- 8 Remove the battery box cover and disconnect the batteries.
- 9 Remove the battery hold-down strap and remove the batteries.
- 10 Remove the battery cable hold-down bracket to the frame rail and disconnect the windshield wiper fluid pump.
- 11 Disconnect the supply and return lines to the windshield washer reservoir. Remove the clamp that secures the drain valve pull cords to the air tanks.
- 12 Remove the air tank straps and the air tanks.

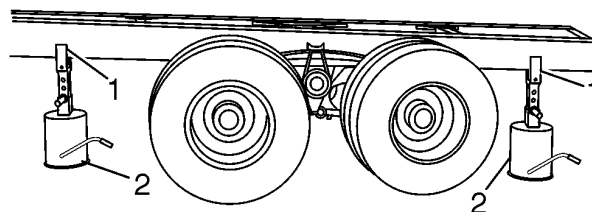

W7001186

- 1 Frame Rail Guide Support
- 2 Air Jack Stand

- 13 Remove the battery tray mounting bolts. Remove the battery and air tank support brackets.

Note: Some applications may require supporting the rear cab suspension.

- 14 Using tool J-44771, support the frame rail being removed with jack stands and frame rail guide supports, which are distributed equally throughout the length of the frame rail.

Note: A minimum of three jack stands and frame rail guide supports of adequate rating should be used for this procedure.

- 15 Disconnect the fuel supply and return line. Remove the fuel tank and fuel tank J- brackets.

- 16 Remove the inner fender splash shield and the lower bracket on the side of the vehicle being worked on.

- 17 Remove the fasteners to the front closing crossmember and the fasteners to the tow hook on the side of the vehicle being worked on.

- 18 Remove the fasteners to the front spring hanger and remove the bumper support bracket.

Note: Support the front engine support crossmember.

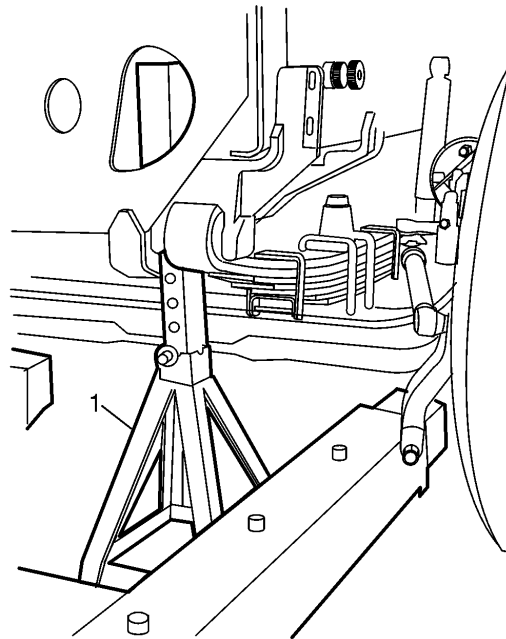

W7001185

1 Jack Stand

- 19 Support the radiator with a jack stand. Remove the radiator support bracket and the lower radiator isolator mount on the side of the vehicle being worked on.
- 20 Remove the pitman arm from the steering gear.
- 21 Stabilize the steering gear and remove the fasteners that mount the steering gear.
- 22 Remove the front axle bump stop from the frame rail on the side of the vehicle being worked on.
- 23 Remove the Air Conditioning line support brackets inside the frame rail and remove the upper shock absorber bolt.

- 24 Remove the steering shaft carrier bearing bracket and/or the power steering reservoir bracket.
- 25 Remove the rear A/C line support bracket, the bulkhead fitting and the wheel speed sensor from the front brake.
- 26 Disconnect the hood release cable and remove the hood tube mount bracket.
- 27 Remove the ground wire and the ground stud located on the frame rail forward of the front cab support.
- 28 Remove any air valves, wiring and/or air line brackets under the cab inside and outside of the frame rail.

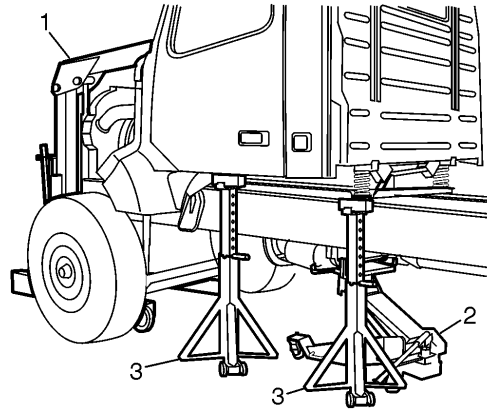

W7001177

- 1 Hoist
- 2 Transmission Jack
- 3 Jack Stand

- 29 Support the front of the cab with a jack stand and remove the front cab support.
- 30 Remove the lower spring pin on the rear spring hanger to the front axle using tool 9996791.
- 31 Remove the rear spring hanger on the front axle.
- 32 Remove the transmission mount bracket and the transmission crossmember mounting bracket on the frame rail being removed.
- 33 Remove the fuel cooler and/or fuel water separator.
- 34 Remove the air dryer and/or purge tank.
- 35 Remove all the remaining clipping brackets from the wiring or air-line harnesses located inside and outside of the frame rail.
- 36 Remove any remaining air valves that are mounted inside or outside the frame rail.
- 37 Support the vertical exhaust pipe in place, then remove the support bracket for the exhaust.
- 38 Support the rear suspension crossmember with a jack stand, then remove the upper shock brackets and the bump stops from the rear suspension.
- 39 Remove all existing fasteners from the rear suspension on the frame rail that is being removed.

- 40 Remove all existing fasteners to the crossmembers on the frame rail being removed.

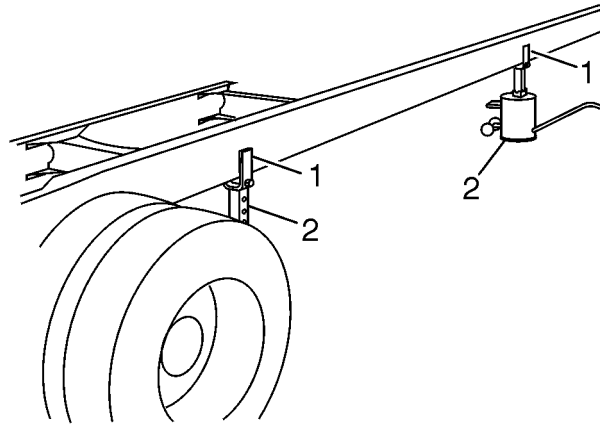

W7001179

- 1 Frame Rail Guide Support
- 2 Air Jack Stand

- 41 Slide and push the frame rail backward, while simultaneously moving the jack stands, one after the other, to the rear of the frame rail. This will adequately support the frame rail while it is being removed.

Installation

Note: Do not tighten fasteners until they have been properly installed. This will help maintain proper frame alignment and will assist in obtaining proper height between the frame rails.

- 1 Slide and push the frame rail forward, while simultaneously moving the jack stands, one after the other, to the front of the frame rail. This will adequately support the frame rail while it is being replaced.
- 2 Install all fasteners and crossmembers on the frame rail being replaced.
- 3 Install fasteners from the rear suspension on the frame rail that is being replaced.
- 4 Install the upper shock brackets and the bump stops to the rear suspension.
- 5 Support the vertical exhaust pipe in place, then install the support bracket for the exhaust.
- 6 Install the air valves to the inside and outside of the frame rail.
- 7 Install all clipping brackets for the wiring or air-line harnesses to the inside and outside of the frame rail.
- 8 Once this step is complete, go back and tighten fasteners that have been installed from steps 1 through 7 as follows:
M14: 200 ± 33 Nm (148 ± 24 ft-lb)
M16: 275 ± 45 Nm (204 ± 34 ft-lb)
- 9 Install the fuel cooler and/or fuel water separator.
- 10 Install the air dryer and/or purge tank.
- 11 Install the transmission mount bracket and the transmission crossmember mounting bracket on the frame rail being replaced.
- 12 Install the rear spring hanger on the front axle.

- 13 Install the lower spring pin on the rear spring hanger to the front axle using 9996791.
- 14 Install the front cab support.
- 15 Install any air valves, wiring and/or air line brackets under the cab inside and outside of the frame rail.
- 16 Install the ground wire and the ground stud located on the frame rail forward of the front cab support.
- 17 Connect the hood release cable and install the hood tube mount bracket.
- 18 Install the rear A/C line support bracket and remove the bulkhead fitting and wheel speed sensor from the front brake.
- 19 Install the steering shaft carrier bearing bracket and/or the power steering reservoir bracket.
- 20 Install the A/C line support bracket inside the frame rail and install the upper shock absorber bolt.
- 21 Install the front axle bump stop to the frame rail on the side of the vehicle being worked on.
- 22 Stabilize the steering gear and install the fasteners that mount the steering gear.
- 23 Install the pitman arm to the steering gear.

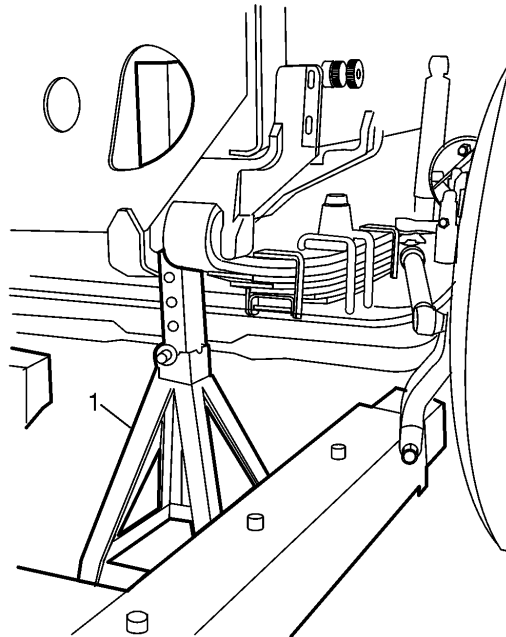

W7001185

1 Jack Stand

- 24 Install the radiator support bracket and the lower radiator isolator mount.
- 25 Install the fasteners to the front spring hanger and reinstall the bumper support bracket.
- 26 Install the fasteners to the front closing crossmember and the fasteners to the tow hook on the side of the vehicle being worked on.
- 27 Install the inner fender splash shield and the lower splash shield support bracket to the frame rail.
- 28 Install the battery tray mounting fasteners and install the battery and air tank support brackets.

- 29 Once this step is complete, go back and tighten fasteners that have been installed from steps 8 through 26, as follows:
M14: 200 ± 33 Nm (148 ± 24 ft-lb)
M16: 275 ± 45 Nm (204 ± 34 ft-lb)
M20: 540 ± 90 Nm (400 ± 67 ft-lb)
- 30 Install the air tank straps and the air tanks.
- 31 Reconnect the supply and return lines to the windshield washer reservoir. Reinstall the clamp that secures the drain valve pull cords to the air tanks.
- 32 Install the battery cable hold down bracket to the frame rail and reconnect the windshield wiper fluid pump.
- 33 Install the battery hold down strap and remove the batteries.
- 34 Install the battery box cover and reconnect the batteries.
- 35 Reconnect the fuel supply and return line. Install the fuel tank and the fuel tank J- brackets.
- 36 Reinstall the engine and transmission. Reinstall the hoist and transmission jack.
- 37 Check the frame alignment and make sure everything is installed and properly tightened to specifications.
- 38 Install the fasteners to the hood pivot blocks and install the hood.
- 39 Install the hood splash shields on the left and right sides of the hood. Connect the hood restraint cylinders.
- 40 Connect the headlamp and foglamp connectors and install the hood spring.
- 41 Install the support rods from the left and right sides of the bumper and install the bumper.
- 42 Install the mounting screws from the top and bottom of the bumper.

Notes

Frame Alignment, Checking

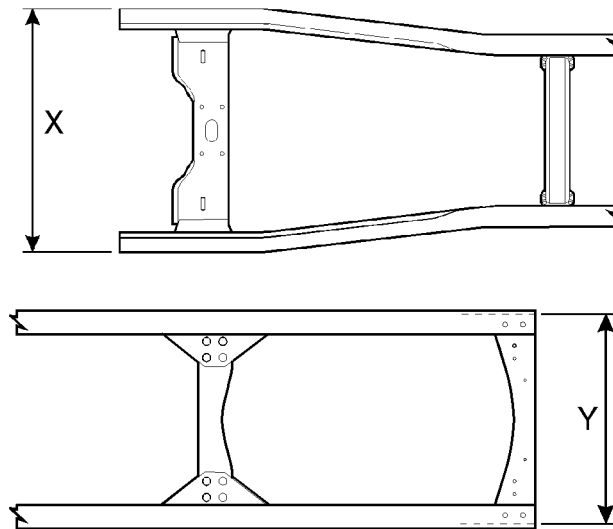

W7001183

X 1080 mm (42.5 in.)

Y 836 mm (32.9 in.), 826 mm (32.5 in.) or 816 (32.1 in.)

- 1 Measure the distance between the outside edges of the front edge of the frame rails. The dimension must be 1080 ± 2 mm.
- 2 Measure the distance between the inside edges of the rear end of the frame rails. The dimension must be 836, 826 or $816 +2.7/-4.6$.
- 3 Ensure the vehicle is on a level area of the shop floor.
- 4 Make a mark on the floor directly beneath the front lower edge of each frame rail, and one directly beneath the rear lower edge of each rail.
- 5 Move the vehicle away from the marks.
- 6 Refer to "Frame Alignment, Adjustment", page 61 . Measure from the mark for the front of the right frame rail to the rear of the left frame rail (this is dimension A).
- 7 Measure from the mark for the front of the left frame rail to the rear of the right frame rail (this is dimension B). This dimension must be the same as dimension A.
- 8 If any of the dimensions noted are not within tolerance, align the vehicle frame.

Notes

Frame Alignment, Adjustment

Total wheel vehicle alignment may be necessary.

- 1 Ensure all crossmember mounting bolts are loose.
- 2 Remove the front bumper and any other obstructions to the front crossmember.
- 3 Remove the front crossmember and the bumper mounting brackets.

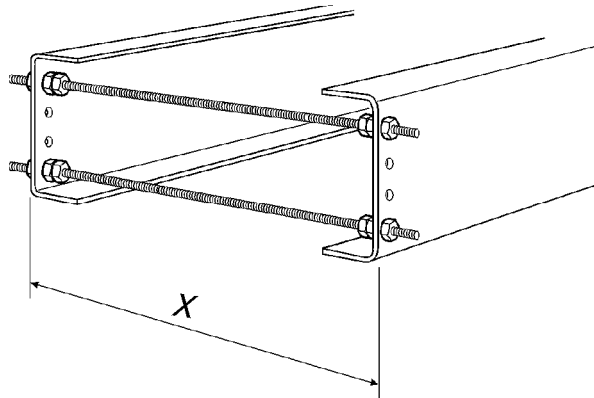

W7001184

X 1080 mm (42.5 in.)

- 4 Insert a 1/2 in. (12 mm) threaded rod, approximately 48 in. (1200 mm) long, through the uppermost front crossmember mounting bracket hole in one frame rail.
- 5 Run four nuts onto the rod so that they are between the frame rails.
- 6 Insert the rod through the uppermost hole in the other frame rail.
- 7 Run a single nut onto the rod on the outside of both rails.

Notes

- 8 Repeat the steps for inserting a threaded rod in the lowest front crossmember mounting bracket hole.

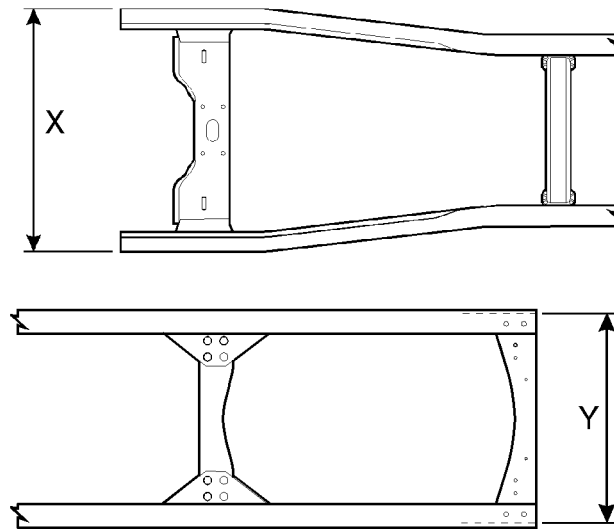

W7001183

X 1080 mm (42.5 in.)

Y 836 mm (32.9 in.), 826 mm (32.5 in.)
or 816 (32.1 in.)

- 9 Adjust the position of the inner and outer nuts to set the distance between the front outer edges of the frame rails to 1080 ± 2 mm.
- 10 Tighten the nuts while ensuring the distance between the rails remains at 1080 ± 2 mm.
- 11 Refer to "Frame Alignment, Adjustment", page 61 . Adjust the position of one of the rails until the crosswise dimension is the same both ways ($A = B$).
- 12 Adjust the distance between the rear end of the rails until the distance between the inside edges is 836, 826 or $816+2.7$ mm/ -4.6 mm .
- 13 Re-verify all dimensions. Readjust if necessary.
- 14 Tighten the mounting fasteners on all crossmembers. Refer to "Tightening Torques, Frame Rail Bolts", page 5 .

Notes

Intermediate Crossmember, Replacement (Rivets Under the Frame Flange)

Removal

- 1 Park the vehicle on a level surface with the transmission in neutral and the front wheels chocked.
- 2 Remove the closing crossmember.
- 3 Remove the harness supports between the closing and the intermediate crossmembers.
- 4 Remove the rear light bar.
- 5 Remove the intermediate crossmember from the vehicle by sliding it out of the frame rail.

Note: Intermediate crossmembers with riveted beams (located forward of the rear suspension) suspension and closing crossmembers must be removed. See "Rear Suspension Crossmember (Bogie), Replacement", page 68 .

Installation

- 1 Install the intermediate crossmember. Tighten fasteners to a torque of:
200 ± 33 Nm (148 ± 24 ft-lb)
- 2 Install the harness supports between the intermediate and the closing crossmember. Tighten fasteners to a torque of:
200 ± 33 Nm (148 ± 24 ft-lb)
- 3 Install the closing crossmember. Tighten fasteners to a torque of:
200 ± 33 Nm (148 ± 24 ft-lb)
- 4 Install the light bar. Tighten fasteners to a torque of:
200 ± 33 Nm (148 ± 24 ft-lb)

Notes

Intermediate Crossmember, Replacement (Bolted and Exposed Rivets)

Removal

- 1 Park the vehicle on a level surface with the transmission in neutral and the front wheels chocked.
- 2 Remove any equipment which obstructs crossmember replacement.
- 3 Remove fasteners or rivets from the installed crossmember beam. Remove the beam from the end plates.
- 4 If required, unbolt and remove the end plates from the frame rails.

Installation

- 1 If required, bolt the new end plates to the frame rails. Do NOT tighten.
- 2 For bolted beams, bolt the new beam to the end plates. For riveted beams, bolt the beam to the end plates using body bound bolts. Perform body bound bolt installation in accordance with the procedure in this document.
- 3 Tighten the end plate-to-the frame rail fasteners. Tighten the beam-to-end plate fasteners. Tighten both fasteners as follows:
M14: 200 ± 33 Nm (148 ± 24 ft-lb)

Intermediate Crossmember, Replacement (Service Kit)

Removal

- 1 Park the vehicle on a level surface with the transmission in neutral and the front wheels chocked.
- 2 Support the drive shaft with transmission jack.
- 3 Remove the four fasteners from crossmember supporting the carrier bearing.
- 4 Remove all side plate fasteners.
- 5 Remove the crossmember using acetylene torch, plasma cutter, cutting wheel or reciprocating saw.
- 6 Remove the parts from packaging.

Notes

Installation

- 1 Install top side plates using supplied fasteners in outermost positions.

Note: Secure remaining holes in webbing frame rail and cross section of crossmember with removed fasteners.

Note: Be sure to install spacers under bolt heads.

Note: Place supplied cross section bolts into top side plate before securing.

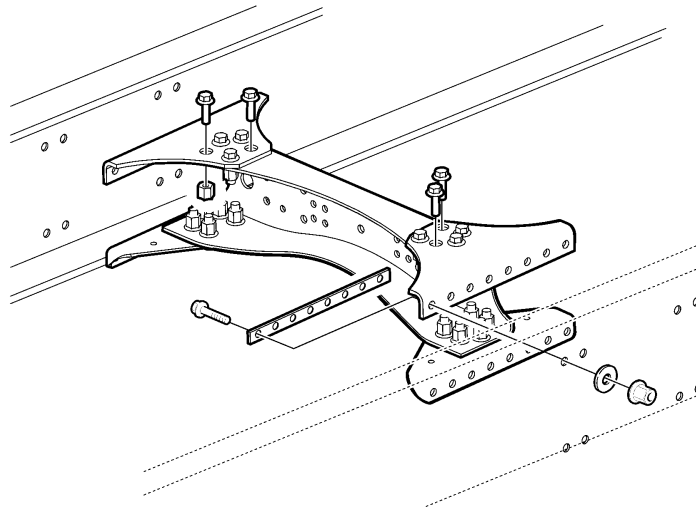

W7036729

- 2 Put cross section in place. Hand tighten top side plate fasteners.
- 3 Install bottom side plates.
Note: Torque 200 ± 33 Nm.
- 4 Move driver side airline aside near crossmember for fastener access.
- 5 Reinstall driver side airline into place.
- 6 Loosen the four carrier bracket fasteners.
- 7 Install drive shaft carrier to cross section in previous position.
- 8 Reposition carrier properly. Secure carrier bracket fasteners.
- 9 Remove jack from drive shaft.
- 10 Secure cab airline.

Closing Crossmember, Replacement

Removal

- 1 Remove taillight assemblies and wiring harness clamps.
- 2 Remove closing crossmember fasteners.



WARNING

Before beginning any service work on any part of the air system, be certain that the air pressure has been released. Failure to do so may cause a component to violently separate, which can result in serious personal injury.

- 3 For air suspension, disconnect and remove air line for left side rear air bag and remove left side upper shock absorber bracket. Also remove leveling valve assembly on 4x2 tractor.
- 4 Remove closing crossmember.

Installation

- 1 Place new closing crossmember between the frame rails.
- 2 Install and tighten the crossmember fasteners. Tighten fasteners to a torque of:
M14: 200 ± 33 Nm (148 ± 24 ft-lb)
- 3 For air suspension, install upper shock absorber bracket and air line for left side rear air bag. On 4x2 tractor, install leveling valve assembly.
- 4 Install taillight assemblies and wiring harness clamps.

Engine Crossmember, Replacement (Rear)



WARNING

Do not remove the coolant fill cap (or cap on the expansion tank) if the coolant is hot; wait until coolant temperature is less than 50° C (120° F). Otherwise, scalding steam or fluid may escape under pressure, which can cause serious injury.



WARNING

Coolant may be combustible. Coolant leaked or spilled onto hot surfaces or electrical components can cause a fire. Clean up coolant spills immediately.



WARNING

Use a hoist or get assistance when lifting components that weigh 23 kg (50 lb) or more. Make sure all lifting devices such as chains, hooks, or slings are in good condition and are of the correct capacity. Make sure hooks are positioned correctly. Always use a spreader bar when necessary. The lifting hooks MUST NOT be side loaded. Failure to follow these warnings may result in personal injury.

Removal

- 1 Park the vehicle on a level surface with the transmission in neutral and the front wheels chocked.
- 2 Remove the ABS modulator valves from the front engine crossmember and/or the frame rails on both sides of the front engine crossmember.
- 3 Support the frame rail on both sides of the front engine crossmember and remove the front spring pins. This step is for VNM and VNL models only.
- 4 Support the front of the engine with a hoist.
- 5 Drain the coolant into a suitable container. Disconnect the lower radiator hose and air cooler hose. This step is for VNM and VNL models only.
- 6 Remove the fasteners that hold the front engine isolator mount to the front engine crossmember.
- 7 Slowly raise the engine with the hoist to separate the isolator from the crossmember.
- 8 Remove the fasteners that mount the front engine crossmember to the spring hangers on the VHD. For the VNM and VNL models, remove the fasteners that mount the spring hangers to the frame rail. For the VHD axle forward, remove the frame bracket on one side to assist in the removal of the front engine crossmember. For the VHD axle back, remove the front engine mount isolator from the engine to assist with the removal of the front engine crossmember.
- 9 Remove the front engine crossmember.

Installation

- 1 Install the front engine crossmember.
- 2 Install the front engine mount isolator on the VHD axle back. Tighten fasteners to a torque of 105 ± 20 Nm (78 ± 13 ft-lb). Install the frame bracket on the VHD axle forward, or install the spring hanger fasteners to the frame rail on the VNM and VNL models. Tighten fasteners to a torque of 200 ± 33 Nm (148 ± 24 ft-lb).
- 3 Lower the engine and install the front engine mount isolator to the front engine crossmember.
- 4 Connect the lower radiator hose and the air cooler hose on the VNM and VNL models. Fill the radiator with coolant.
- 5 Install the front spring pins on the VNM and VNL models. Tighten fasteners to a torque of:
 85 ± 15 Nm (63 ± 11 ft-lb)
- 6 Install the front ABS modulator valves. Tighten fasteners as follows:
M10: tighten to a torque of 60 ± 10 Nm (44 ± 7 ft-lb)

Notes

Rear Suspension Crossmember (Bogie), Replacement

Removal

- 1 Park the vehicle on a level surface with the transmission in neutral and the front wheels chocked.
- 2 Remove the rear light bar and mud flaps.
- 3 Remove the closing crossmember. See "Closing Crossmember, Replacement", page 66 .
- 4 Remove the harness support brackets that are located between the rear suspension crossmember and the closing crossmembers.
- 5 Remove the airline support brackets located under the rear suspension crossmember.



WARNING

Before beginning any service work on any part of the air system, be certain that the air pressure has been released. Failure to do so may cause a component to violently separate, which can result in serious personal injury.

- 6 Remove the brake valves and brake hoses that are mounted to, or located at, the rear suspension. Also remove the Traction Control Valve (TCS) mounted to the frame rail if the vehicle is equipped with TCS.

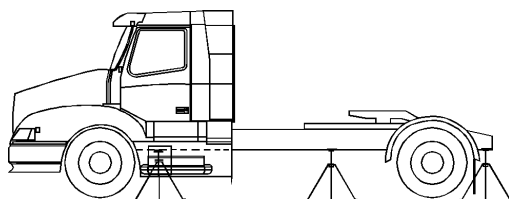

W0000411

- 7 Using jack stands, support the nose of the first and second drive axles and the rear section of the frame rails.
- 8 Remove the bump stops and the upper shock brackets for the rear drive axle.
- 9 Remove the intermediate crossmember. See "Intermediate Crossmember, Replacement (Bolted and Exposed Rivets)", page 64 .
- 10 Remove the fasteners for the spring hangers on the rear drive axle on trucks equipped with the Volvo Optimized Air Suspension.
- 11 Remove the V-torque rod on trucks equipped with the Volvo T-Ride.
- 12 Remove the leaf spring assembly on each side of the suspension on trucks equipped with the Volvo T-Ride.
- 13 Support the saddle bracket on each side of the suspension on trucks equipped with the Volvo T-Ride.
- 14 Remove the fasteners to the saddle bracket on each side of the rear suspension on trucks equipped with the Volvo T-Ride.
- 15 Remove the fasteners to the V-torque rod on the first drive axle at the frame bracket if the truck is equipped with the Volvo T-Ride.
- 16 Remove the remaining fasteners to the rear suspension (Bogie) crossmember and remove the rear suspension (Bogie) crossmember.

Installation

- 1 Once this step is complete, go back and tighten fasteners that have been installed from steps 1 through 7 as follows:
- 2 Install the rear suspension (Bogie) crossmember. Install and tighten fasteners as follows:
M14: tighten to a torque of 200 ± 33 Nm (148 ± 24 ft-lb)
M16: 275 ± 45 Nm (204 ± 34 ft-lb)
- 3 Install the fasteners between the V-torque rod and the frame bracket and apply the proper torque to trucks equipped with the Volvo T-Ride.
M14: 200 ± 33 Nm (148 ± 24 ft-lb)
M16: 275 ± 45 Nm (204 ± 34 ft-lb)
- 4 Install the fasteners to the saddle brackets and apply the proper torque on trucks equipped with the Volvo T-Ride.
M14: 200 ± 33 Nm (148 ± 24 ft-lb)
M16: 275 ± 45 Nm (204 ± 34 ft-lb)
- 5 Install the leaf spring assembly on each side and tighten the U-bolts to the saddle caps on trucks equipped with the Volvo T-Ride. Tighten the U-bolts to a torque of 500 ± 75 Nm (369 ± 55 ft-lb).
- 6 Install the fasteners to the spring hangers on the rear drive axle and apply proper torque on trucks equipped with the Volvo Optimized Air Suspension.
- 7 Install the intermediate crossmember and tighten the fasteners to a torque of 200 ± 33 Nm (148 ± 24 ft-lb).
- 8 Install the upper shock brackets and the bump stops and the tighten fasteners.
- 9 Install the brake valves and hoses located near the rear suspension crossmember.
- 10 Install and properly tighten the V-torque rod, on trucks equipped with the Volvo T-Ride. Tighten the V-torque rod nuts (axle housing) as follows to a torque of 310 ± 50 Nm (228 ± 37 ft-lb). Tighten the V-torque rod bolts (chassis bracket) to a torque of 320 ± 50 Nm (236 ± 37 ft-lb).
- 11 Install all the harness and airlines mounting brackets.
- 12 Install the light bar and mud flaps.
- 13 Install the closing crossmember. See "Closing Crossmember, Replacement", page 66 .
- 14 Remove any supports for the frame rails and the drive axle.

Notes

Rear Suspension Crossmember (Bogie), Replacement (Aluminum)

Removal

- 1 Park the vehicle on a level surface with the transmission in neutral and the front wheels chocked.
- 2 Remove the fasteners that mount the fifth wheel to the fifth-wheel angles and slide the fifth wheel forward out the way.
- 3 Jack up the truck and place jack stands under rear drive axle and frame.
- 4 Remove both right and left rear drive tires and wheels.
- 5 Remove the pneumatic valve package from the rear suspension crossmember.
Note: It should not be necessary to disconnect any air lines from the valve package.
- 6 Place a jack stand under the nose of the rear drive axle housing to keep the front of the differential from dropping down when all of the Huck fasteners are removed.
- 7 Using the Huck removal tool, remove the Huck fasteners mounting the crossmember from both sides of the frame rail. Remove fasteners mounting the crossmember to the frame rails if not equipped with Huck fasteners.
Note: If some of the Huck fasteners are too long, you will need to use a right angle grinder to cut off some of the excess from the threaded end of the Huck fasteners.
- 8 Using a saw of adequate rating, cut through the cross section of the crossmember being removed and remove the crossmember.
Note: If an Aluminum crossmember is being replaced by an Aluminum crossmember, then there is no need to cut the cross section for removal; just unbolt the end caps and remove the crossmember.

Notes

- Using the illustrations provided as reference, lay out and mark positions for additional holes needed in the right and left frame rails and drill additional holes needed for installation of the Aluminum crossmember.

Note: If an Aluminum crossmember is being replaced by an Aluminum crossmember, then no additional holes need to be drilled in the frame for installation.

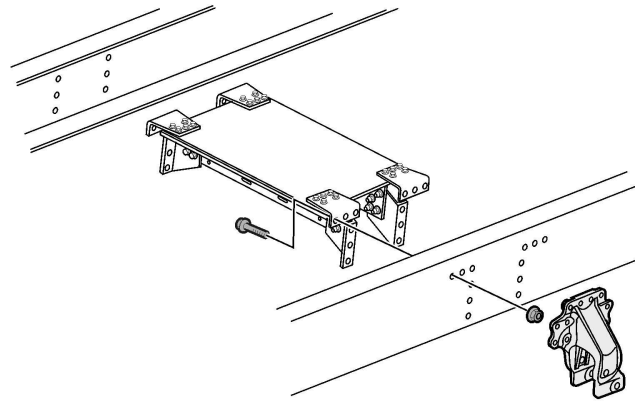

W7001470

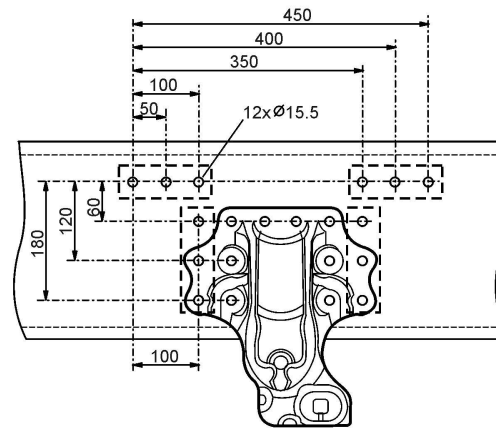

W7001471

- Remove the end plates from the Aluminum crossmember so that the crossmember can be installed between the frame rails.

Installation

- Position the crossmember between the frame rails and install end caps to crossmembers. Install fasteners but do not tighten at this time.
- Install bolts through the frame to the crossmember.
- Install bolts for all stand off brackets for the electrical and pneumatic harnesses also installing bolts into all unused bolt holes in the frame.

Note: Install bolts but do not tighten at this time.

- Tighten all bolts in the frame and torque to 156 Nm (115 ft-lb).
- Tighten all bolts in the crossmember and torque to 65 Nm (48 ft-lb).
- Bolt the pneumatic valve to the crossmember.
- Install the fifth wheel on the fifth wheel angles.
- Install both right and left side wheels and tires. Torque lug nuts to 780 Nm (575 ft-lb).

Rear Suspension Crossmember (Bogie), Replacement (Steel to Aluminum)

Removal

- 1 Park the vehicle on a level surface with the transmission in neutral and the front wheels chocked.
- 2 Remove the fifth-wheel fasteners from the fifth-wheel angles and slide the fifth wheel forward out of the way.
- 3 Jack up the truck and place jack stands under rear drive axle.
- 4 Remove both the right and left rear drive tires and wheels.
- 5 Remove the pneumatic valve package from the rear suspension crossmember.
- 6 Place a jack stand under the nose of the rear drive axle housing to keep the front of the differential from dropping down when all of the Huck fasteners are removed.
- 7 Using the Huck removal tool, remove the Huck fasteners from both sides of the frame rail.
Note: If some of the Huck fasteners are too long you will need to use a right angle grinder to cut off some of the excess from the threaded end of the Huck fastener.
- 8 Remove the end plates from the crossmember so that the crossmember can installed between the frame rails.
- 9 Position the crossmember between the frame rails and install end caps to crossmembers. Install fasteners but do not tighten at this time.

Installation

- 1 Install the bolts through the frame rails.
- 2 Install bolts for all stand off brackets for the electrical and pneumatic harnesses, also installing bolts into all unused bolt holes in the frame.
Note: Install bolts but do not tighten at this time.
- 3 Tighten all bolts in the frame at this time and torque to 156 Nm (115 ft-lb).
- 4 Tighten all bolts in the crossmember at this time and torque to 85 Nm (ft-lb).
- 5 Bolt up the pneumatic valve to the crossmember.
- 6 Install the fifth wheel on the fifth wheel angles.
- 7 Install both right and left side wheels and tires, torque lug nuts.

Notes

Frame Length, Adjustment



WARNING

Always wear appropriate eye protection to prevent the risk of eye injury due to contact with debris or fluids.

Note: Total wheel vehicle alignment may be necessary after completing this procedure. Refer to the appropriate service information.

Note: The only approved alteration to the frame is shortening of the vehicle wheelbase by moving the rear axle(s) forward and cutting the excess frame from the end. Frame rails are not to be spliced or extended.



WARNING

Before beginning any service work on any part of the air system, be certain that the air pressure has been released. Failure to do so may cause a component to violently separate, which can result in serious personal injury.



WARNING

Use a hoist or get assistance when lifting components that weight 23 kg (50 lb) or more. Make sure all lifting devices such as chains, hooks, or slings are in good condition and are of the correct capacity. Make sure hooks are positioned correctly. Always use a spreader bar when necessary. The lifting hooks **MUST NOT** be side loaded. Failure to follow these warnings may result in personal injury.

- 1 Place the vehicle on jack stands at the normal ride height. Do not jack the vehicle up.

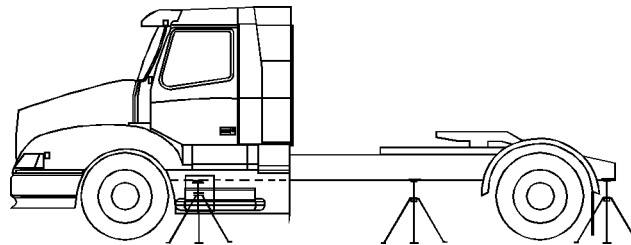

W0000411

- 2 Remove the driveshaft.
- 3 Unbolt the fifth-wheel angle irons from the frame and remove the fifth wheel and the angle irons as an assembly.
- 4 Mark the frame at the existing wheelbase (center line of the rear axle for single axle and center between axles for a tandem axle).
- 5 Unbolt the existing suspension brackets, hardware, and crossmembers.
- 6 Unbolt and remove any other brackets, hoses, or electrical wiring that obstruct the area of the frame to be altered.
- 7 Remove any intermediate crossmember that will no longer be needed.
- 8 Make a template of the hole pattern for the rear suspension using the existing wheelbase and hole pattern as reference points.
- 9 Determine the new wheelbase for the vehicle and mark on the frame rails.
- 10 Mark and drill the new holes necessary to accommodate the rear axle crossmember at its new position. Refer to "Bolt Hole Patterns", page 17 .
- 11 Unbolt the rear axle crossmember end plates from the frame and move the crossmember to its new position.

- 12 Bolt up the suspension and crossmembers. Tighten the fasteners as follows:
 14 200 ± 33 Nm (148 ± 24 ft-lb)
 M16: 275 ± 45 Nm (204 ± 34 ft-lb)
- 13 Remove the jack stands from under the frame.
- 14 Determine the appropriate minimum overhang from the table below.

Axle Type	Overhang		
	Straight End	Tapered end*	Tapered end**
4x2	838 mm	813 mm	889 mm
6x4	1371 mm	1346 mm	1422 mm

* For bar type mud flap brackets** for spring type mud flap brackets

- 15 Measure rearward from the new center line of the rear axle (4x2) or from the new center line of the bogie (6x4) the overhang amount. Mark that point on the frame rails as the **desired end of frame**. **DO NOT CUT THE FRAME**.

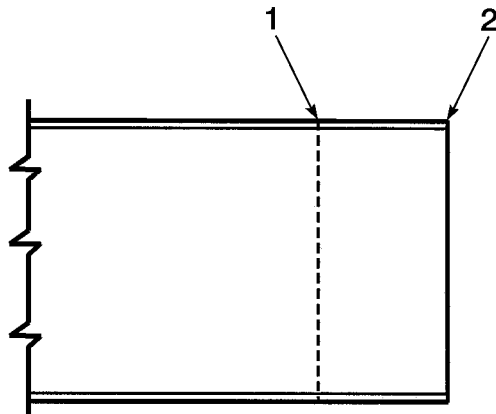

W7001167

- 1 Desired End of Frame
- 2 Current End of Frame

- 16 For tapered rail ends only, mark the frame rail at a point 28.5 mm (266 mm frame height) or 36 mm (300 mm frame height) past the mark for desired end of frame. This is the **rough cut** mark.

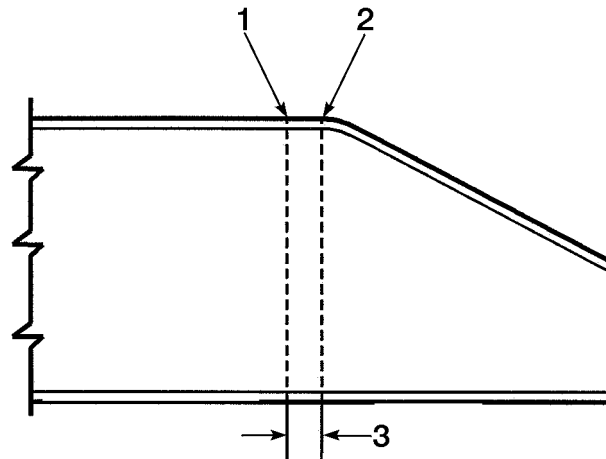

W7001168

- 1 Desired End of Frame
- 2 Rough Cut
- 3 28.5 mm (266 mm frame)
36.0 mm (300 mm frame)

- 17 For straight rails, cut the excess frame off at the mark for **desired end of frame**. For tapered rails, cut the excess frame off at the mark for **rough cut**.

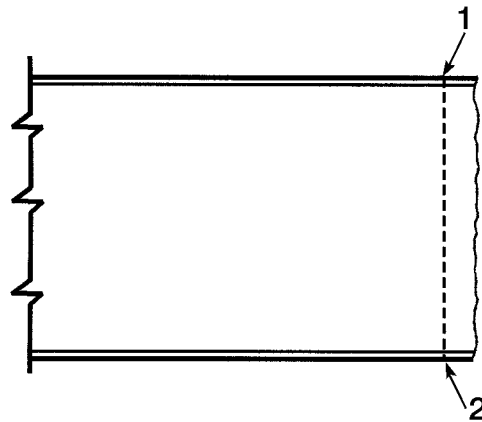

W7001169

- 1 Desired End of Frame
- 2 Rough Cut

- 18 Insert the closing crossmember between the frame rails and slide it as far forward as possible.

Note: Steps 20 through 29 for cutting, beveling, and welding the frame web apply only to vehicles that require a tapered closing crossmember.

19 Mark a wedge shape on the frame web for cutting. Refer to the table below for dimensions.

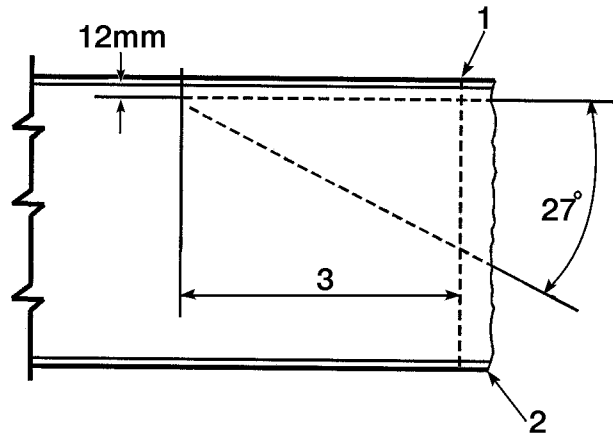

W7001170

- 1 Desired End of Frame
- 2 Rough Cut
- 3 See Table for Dimensions

Frame Height	Frame Thickness				
	6 mm	7 mm	8 mm	9.5 mm	11 mm
266 mm	219.8 ± 2 mm	217.6 ± 2 mm	215.9 ± 2 mm		
300 mm	280.7 ± 2 mm	278.7 ± 2 mm	276.7 ± 2 mm	274.8 ± 2 mm	271.6 ± 2 mm

20 Drill a 24 mm diameter hole with center at the upper corner of the wedge (12 mm below the bottom of the upper flange).

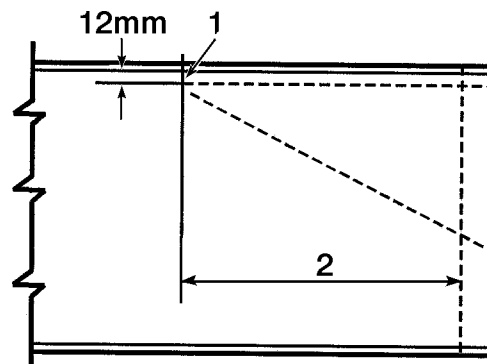

W7001171

- 1 Drill Hole Here
- 2 See Table for Dimensions

21 Verify the angle of the wedge is $27 \pm 0.25^\circ$.

22 Cut out the wedge.

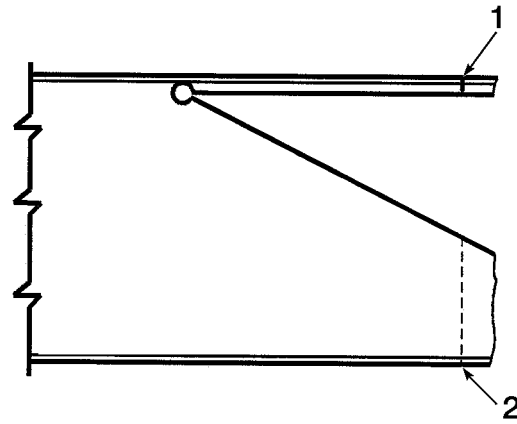

W7001172

- 1 Desired End of Frame
- 2 Rough Cut

23 Bevel the outer edges of the cuts to 45°.

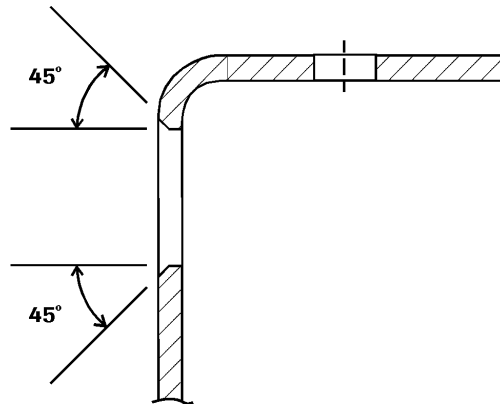

W7000390

24 Bend the upper flange down until it makes contact with the web.

Note: It may be necessary to heat the flange in order to bend it.

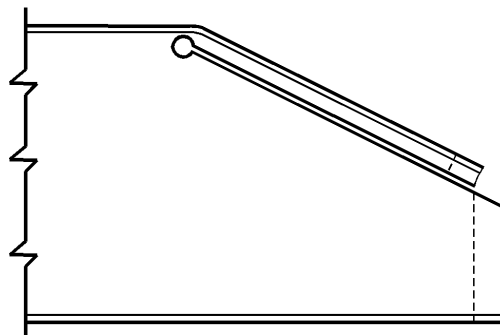

W7000408

25 Verify the proper fit up of the tapered crossmember before welding.



WARNING

Eye injury hazard. Wear eye protection during welding. Failure to wear eye protection could result in severe eye injury and blindness.

- 26 Weld the cut edges of the web together.

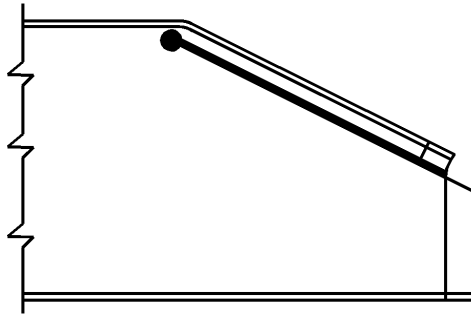

W7000413

- 27 Cut off the end of the frame rail at the desired end frame mark.

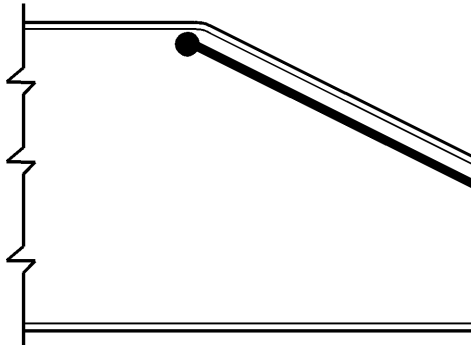

W7000414

- 28 Repeat the cutting and welding process for the other frame rail.
29 Measure, mark and drill holes in the frame to accommodate the closing crossmember.

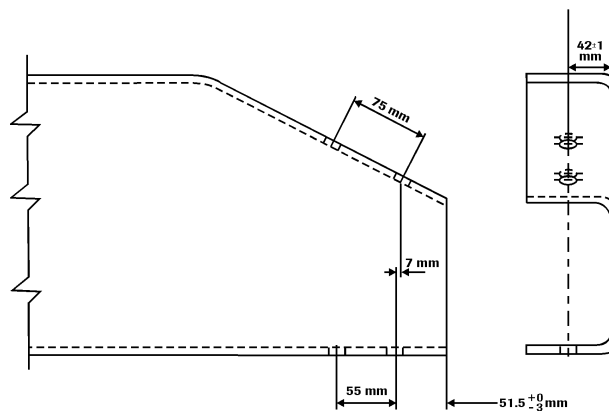

W7000391

- 30 Grind the end of the frame and the welded areas smooth and paint all bare metal frame surfaces.

- 31 Slide the closing crossmember into place. Tighten tapered crossmember bolts to:
275 ± 45 Nm (203 ± 33 ft-lb)

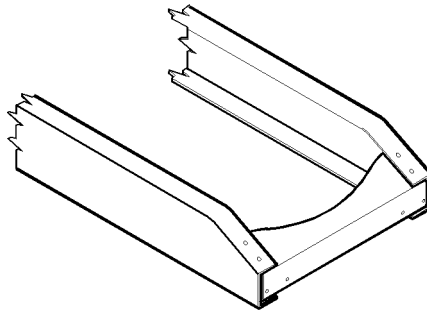

W7000378

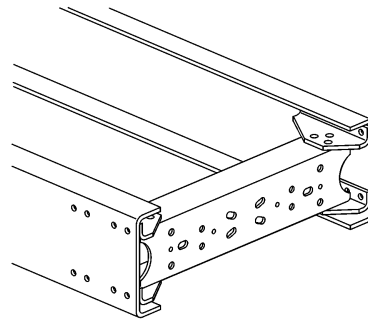

W7001284

- 32 Mark and drill holes for the fifth-wheel angle irons. Bolt the fifth-wheel assembly to the frame and tighten bolts to:
275 ± 45 Nm (203 ± 33 ft-lb)
- 33 Install and tighten an appropriate size metric flange bolt into each frame rail web hole that is not used.
- 34 Measure distance from transmission pinion to axle pinion, and record the distance. Have a certified drive-line shop alter the driveshaft for this distance.
- 35 Install the driveshaft.
- 36 Check the pinion angles and ride height, if necessary make corrections.

Notes

Body Bound Bolt, Installation



WARNING

Always wear appropriate eye protection to prevent the risk of any eye injury due to the contact with debris or fluids.



CAUTION

Only use a reamer with clockwise rotation. Do not reverse rotation to remove the reamer. Use a drill with a maximum 350 rpm no-load speed. Always use cutting oil. Failure to follow these precautions will result in damage to the reamer.

- 1 Ream the holes in the crossmember and end plates or bracket to 16.56 mm (0.652 in.).
- 2 Clean out any metal chips that remain in the holes.
- 3 Measure the thickness of the end plate or spring bracket.

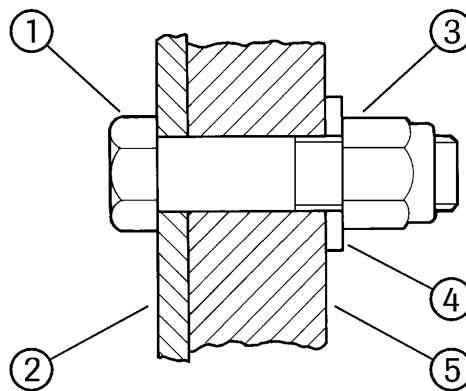

W7000383

- 1 Body bound bolt
- 2 Crossmember
- 3 Elastic stop nut
- 4 Hardened flat washer
- 5 End plate or spring bracket

- 4 Multiply the thickness from Step 3 by 66%.
- 5 Measure the thickness of the crossmember.
- 6 Add the thickness values from Steps 3 and 5. This is maximum bolt shank length.
- 7 Add the thickness values from Steps 4 and 5. This is minimum bolt shank length.
- 8 Select a body bound bolt with a shank length between the minimum and maximum shank length.
- 9 Install the body bound bolts in each hole that was reamed. Place a hardened steel washer and a stop nut on each bolt.
- 10 Tighten the nuts to:
225 ± 37.5 Nm (166 ± 28 ft-lb)
Hit the bolt with a brass hammer several times during torquing to insure proper seating.

HUCKBOLT® Permanent Fastener, Removal

The HUCKBOLT Permanent fasteners have a “swagged” over the grooved pin. No amount of twisting or hammering will dislodge or remove the pin from the collar. The collar must be cut parallel to the HUCKBOLT pin end of the swagged section. This is best accomplished with a small wheel grinder. Other options may be to use a drill or chisel to create openings on the collar wall.

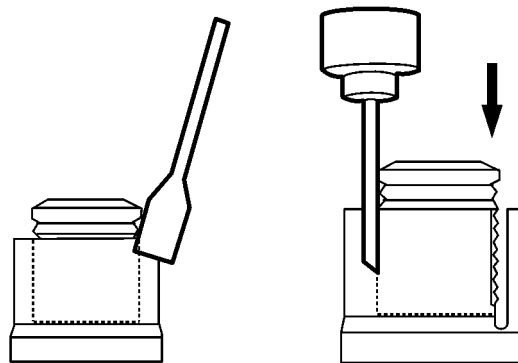

W7001282

Fig. 17 Optional Collar Removal Procedures



CAUTION

HUCKBOLT® Permanent Fasteners are clamped at a very high torque and they may release suddenly. Wear proper eye protection and keep your face at least two feet away from the collar. **Do not use a cutting torch for removal.**

Note: For further information on Huck fasteners refer to

http://www.arconic.com/global/en/products/product.asp?bus_id=1&cg_id=77&cat_id=1443&prod_id=900.

- 1 Using a wheel grinder (preferred method) cut a vertical groove into the “swagged” section of the HUCKBOLT® collar on two or more sides (see arrow in Fig. 17).

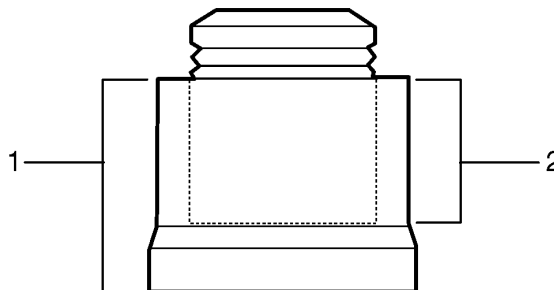

W7001283

- 1 Collar Section
- 2 Swagged Section

- 2 After the collar is opened over the length of the swagged portion on two or more opposing sides, the pin may become free. If not, additional collar material should be pulled away from the swagged section of the collar using vice grips or a chisel.

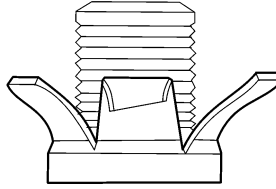

W7001274

- 3 Remove the pin after sufficient material is pulled away from the swagged section of the collar.

Note: Any fastener that is removed should be replaced with a fastener of equal or greater strength.

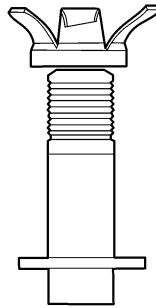

W7001276

Notes
