



Electrical, Electronic Control Unit (ECU) VN, VHD, VAH Section 3

Introduction

This information provides details for the electronic control unit (ECU) applications for Volvo vehicles.

Note: For basic operator information, refer to the Operator's Manual.

Note: We have attempted to cover as much information as possible. However, this information does not cover all the unique variations that a vehicle chassis may present. Note that illustrations are typical but may not reflect all the variations of assembly.

All data provided is based on information that was current at time of release. However, **this information is subject to change without notice.**

Please note that no part of this information may be reproduced, stored, or transmitted by any means without the express written permission of Volvo Trucks North America.

Contents:

- "ISO 26262 Functional Safety Manual", page 4
- "General Wiring Definitions", page 5
- "Routing and Clipping Guidelines", page 6
- "Battery Cable Guidelines", page 11
- "Body Builder Preparation Packages", page 16
- "Body Builder Harness ", page 18
- "Body Builder Connections End of Frame", page 20
- "Body Builder Pass Through Connectors (VHD)", page 22
- "VHD Body Builder Connectors", page 23
- "Allison Controlled Relays ", page 31
- "PTO1 Input/Enable and Output ", page 32
- "VHD Body Builder Wiring", page 33

- “Data Link Communication”, page 38
- “Supported SAE J1939 Serial Messages”, page 40
- “Supported SAE J1587 Serial Messages”, page 49
- “SAE J1939 Control Data Link”, page 57
- “SAE J1587/1708 Information Data Link”, page 59
- “ISO 14229 Data Link”, page 59
- “Vehicle Accessory Connector (RP1226)”, page 61
- “ECU Functions and Parameter Programming”, page 65
- “Cummins Engine Control Module (ECM)”, page 71
- “Cruise Control”, page 72
- “Manual Fan Input”, page 74
- ““Stalk” PTO Operation”, page 76
- ““Remote” (Wired) PTO1 Operation with VECU (Volvo Engines Only)”, page 78
- “Description of VECU Signals”, page 84
- “Engine Shutdown Inputs”, page 88
- “Resume to Pre-set Speed”, page 90
- “Engine Speed Limit Input”, page 91
- “Engine Torque Limit Input”, page 92
- “Road Speed Limit Input”, page 93
- “Neutral Gear Input”, page 96
- “Low Split Gear Input”, page 97
- “Split Shaft (Split Box) PTO Input”, page 98
- “Remote Throttle/2nd Accelerator Pedal”, page 101
- “Road Speed (C3) Output”, page 105
- “System Warning Output”, page 108

- “PTO Engine Speed Control Inputs”, page 113
- “PTO Engine Speed Increment/Decrement Inputs”, page 119
- “PTO Output Control (Inputs and Outputs)”, page 120
- “Body Builder CAN (J1939) Interface”, page 124
- “BBM Connector A (Orange 30–way)”, page 126
- “Summary of Adjustable VECU/BBM Parameters”, page 129
- “Supplemental Restraint System”, page 143
- “Body Builder Module”, page 144
- “Climate Control (ECC/MCC)”, page 145
- “Instrument Cluster”, page 146
- “Light Control Module”, page 147
- “Add-on Exterior Lighting”, page 148
- “Transmission Control Module”, page 152
- “Vehicle Electronic Control Unit (VECU)”, page 153
- “Parameter List”, page 155
- “Switches and Controls”, page 163
- “Remote Start and Stop, VAH and VHD”, page 177

ISO 26262 Functional Safety Manual

Scope

This section describes the functional safety aspects related to the interface between the vehicle and the body builder equipment.

Introduction

ISO 26262 is the functional safety standard for road vehicles. Functional safety addresses safety related functionality implemented in electronics and software. Volvo Trucks has during 2018 initiated development of new vehicle functions and systems according to ISO 26262 after the standard became applicable to trucks, buses and trailers. Before ISO 26262, Volvo Trucks followed other internal processes addressing functional safety.

The truck will gradually be made compliant to ISO 26262. However, it will take several years until the complete truck is compliant to the standard.

The status of the truck related to functional safety with regards to ISO 26262 will be described in this section. Continuous updates will be made to reflect the current status of the truck.

The ASILs of the body builder interface characteristics will be documented and it will be described in which sense the interfaces meet the different ASILs. This section will also contain information on requirements and constraints for the usage of the body builder interface. In case specific safety measures have to be applied by the body builder, this shall be stated in this section.

When a body builder needs anything that is not described or when the ASIL of the characteristic is not according to the body builders expectations, the body builder shall contact Volvo Trucks for guidance. This section will be referenced from other body builder sections when applicable.

Current status of the truck in relation to ISO 26262

The existing trucks are developed according to Volvo Trucks internal process addressing functional safety, applicable before ISO 26262.

Presently no functions or systems in the trucks have been developed according to ISO 26262.

General Wiring Definitions

The general wiring definitions provides a standardized list of terminology used in running wires, hoses, and cables throughout the vehicle.

Abrasive Surface	Items capable of causing damage to the routed commodity in a rubbing condition during vehicle operation
AWG	American Wire Gauge
Bundled With	A number of items tied, wrapped, or otherwise held together
Cable Tie	A nylon plastic self-sizing strap, UV resistant, capable of bundling specified load(s) during vehicle operation
Chafing	To wear away by rubbing
Contacts	Items touching each other
Crimped	A routed commodity that is bent or pressed into ridges
Damaged	An item that differs from its original condition
Drooping	Routed items hanging downward which are detrimental to safe vehicle operation
Dual Fall	(Pertaining to the Compressor Discharge Line) A high point in the routing of the Compressor Discharge Line (located on the engine) whereby any collected moisture is allowed to fall in two different directions where it is either dissipated by heat or is purged
High Current Electrical Cables	Wire sizes 13 mm sq. (0.5 inches sq.) (6 AWG) and larger
High Nut	Extended clamp length
Kinked	A tight bend, curl, or twist in the routed commodity causing flow to be restricted
Low Current Electrical Cables	Wire sizes 8 mm sq. (0.3 inches sq) (8 AWG) and smaller
Low Nut	Standard clamp length
Material Grade 30	Minimum yield strength of 30,000 psi
Material Grade 50	Minimum yield strength of 50,000 psi
May	Verb typically used in a statement of practice that is a permissive condition and carries no requirement or recommendation. It can be included to alter statements of mandate or recommendation
Not Secured	Items not fastened, bundled or tied
Plastic Conduit	Corrugated or smooth wall tubing used to protect hoses, harnesses, cables, tubing, pipes, etc.
Puncture	Small hole or wound
Routed With	Items taking the same path but not attached to each other (i.e., parallel but separate)
Rubbing	Items that contact each other and have independent movement
Shall	Verb typically used in a statement of required, mandatory or specifically prohibitive practice regarding routing and clipping
Sharp Edge	A surface capable of cutting or piercing the routed commodity during vehicle operation
Should	Verb typically used in a statement of recommended, but not mandatory, practice in typical situations with deviations allowed if Engineering judgement or Engineering study indicates the deviation is appropriate

Twisted	Distorted from the routed commodities' original shape about it's cross-sectional center line
Touch	Items that contact each other but do not have relative movement

Routing and Clipping Guidelines

- 1 Brackets used in routing and clipping should be Material Grade 50 or better to ensure sufficient clamp load when sharing joint connections with cross members or other structural members. This applies only to joint connections using a low nut. Brackets of Material Grade 30 are acceptable provided the shared joint is using a high nut. The area of the clip bracket under the bolt head must be a least as large as the bolt head itself.
- 2 Clips that scratch exterior mounting surfaces shall not be used (i.e., barbed/spring type) unless the material is non-corroding (i.e., plastic). Clips must have rust protection.
- 3 Clip sizes should adequately secure the bundle without restricting flow, causing collapse, or preventing relative movement.
- 4 Bundles shall be supported at 24 inches (600 mm) maximum intervals, a cable tie should be used between clip points on bundles with the exception of electrical wiring harness which shall have a maximum support distance of 18 inches (450 mm) and a cable tie on bundles between clip points. When air and electrical lines are bundled together, the commodity with the greater cross sectional area may determine the support spacing. A minimum of two cable ties shall be used between clip points to bundle electrical lines when the larger interval is used.

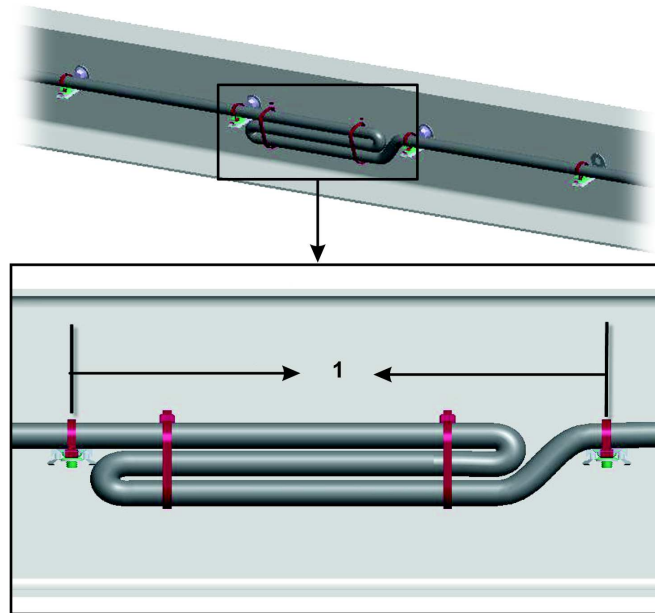

W3104131

1 Support electrical cables every 18 inches (450 mm)

Support Distances, Continued

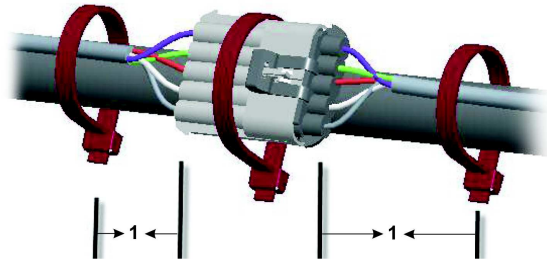

W3104144

1 Support cables near connectors every 4 inches (100 mm)

- 1 Electrical cables and wiring harnesses are to be secured 4 inches (100 mm) from the wire insertion end of the connector or clipped to the body.
- 2 Routing and clipping on purchased components (i.e., engine/transmission) should not include removing or replacing a bolt(s), nut(s) or screw(s) installed by the manufacturer. In such cases where this is unavoidable, the bolt(s), nut(s) or screw(s) shall be re-installed to the manufacturer's specifications.
- 3 Bundles should not contact sharp edges of cross members. Contact may occur if it is against a smooth surface, a smooth radiused edge or a coined edge and the bundle is secured to prevent independent movement.
- 4 Hoses, tubing, pipes and electrical conduits shall not rub each other but may touch.
- 5 The fabric braided portion of the compressor discharge hose is compatible to be bundled with all routed air lines.
- 6 The compressor discharge pipe shall be routed independent of all other routing.
- 7 Electric cables/harnesses must not be bundled with fuel or hydraulic lines. The electrical cables/harnesses may be routed parallel with fuel or hydraulic lines, however must remain separated by approved clipping materials. When design control is possible, electrical cables/harnesses will be routed above fuel or hydraulic lines. If fuel or hydraulic lines must route above circuit protected electrical cables /harnesses, the fuel or hydraulic lines will have no fittings or potential leak points above electrical cables/harnesses and shall be minimized to the shortest distance possible over low current electrical cables/harnesses.
- 8 All associated markings on air and electrical harnesses should have a corresponding clipping apparatus.
- 9 Critical clipping locations shall be designated on the component to insure proper placement in the vehicle (i.e., tape).
- 10 Maximum support distance for compressor discharge rigid pipe, 30 inches (762 mm). Pipe to be isolated from support brackets (i.e. rubber isolator).
- 11 Maximum support distance for compressor discharge flex hose, 24 inches (600 mm).
- 12 Compressor discharge line should have a constant fall from compressor to air dryer. A dual fall is allowable provided it occurs on the engine and within 24 inches (600 mm) of the compressor.
- 13 Maximum allowable dip in compressor discharge pipe/hose is one half the outer diameter of the pipe/hose. Preferred routing should have no dips in any of the routing. This is to avoid line blockage due to water collecting and freezing in the line.

Heating Specifications

In order to maintain the integrity of the cables and hoses, observe the following specifications for routing near a heat source.

Cable, hose, or harness type	Specification
Electrical cables and wiring harnesses	5 inches (130 mm) in all directions from turbocharger, exhaust components, and other high heat components
Unprotected hoses, tubing, harnesses, and cables	6 inches (150 mm) above, 5 inches (130 mm) beside and 4 inches (100 mm) below
Hoses, tubing, harnesses, and cables protected by reflective heat sheathing	3 inches (76 mm) above, 2 ½ inches (63,5 mm) beside and 2 inches (51 mm) below
Silicone transmission coolant hoses	2 inches (51 mm) from exhaust manifold and turbo (with reflective heat sleeving), 1 inch (25 mm) from exhaust pipe
Hoses, tubing, harnesses, and cables protected by a heat shield (no reflective sheathing)	3/8 inch (10 mm) between the component and the heat shield. (Not valid for fuel lines)
Refrigerant suction hoses	8 inches (200 mm)

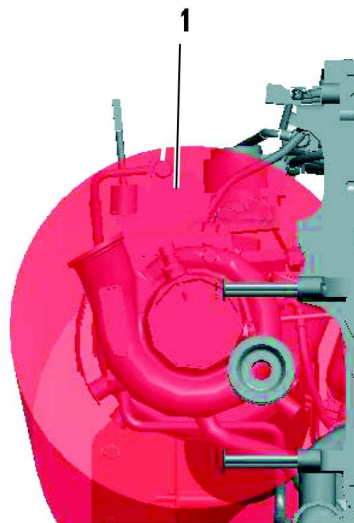

W3109897

1 Heat Radius from the Turbocharger, Front: 5 inches (130 mm)

Clipping Guidelines

Clipping brackets should be designed and mounted to adequately support the bundle. Clips should be mounted in a hanging position or supported along three-quarters of the horizontal mounting surface. Orientations that do not conform to the illustrations shall be tested.

- 1 When hoses, wires, and cables cross one another, secure them with a clamp. This prevents the sawing motion that could abrade them.
- 2 When routing flex hoses that are bent in two planes, clip them to prevent twisting. Clamp the hose at the point where the hose changes planes. The clamp has the effect of dividing the hose into two assemblies. If the section of the hose is bent in the same plane as the movement, the bend will absorb the movement and the hose will not twist.

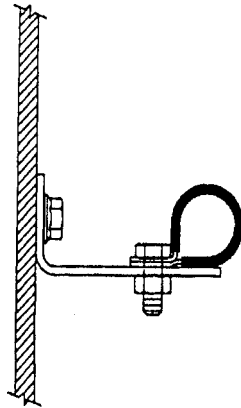

ACCEPTABLE

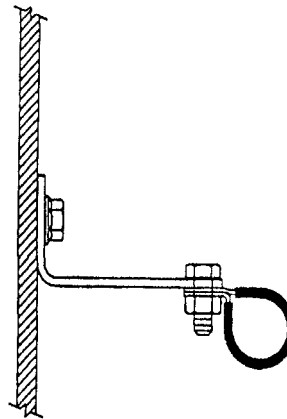

NOT ACCEPTABLE

W3103550

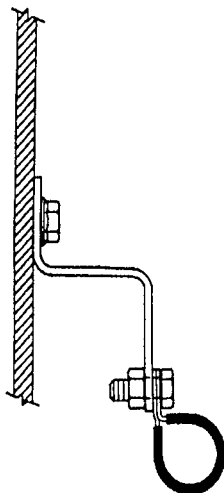

ACCEPTABLE

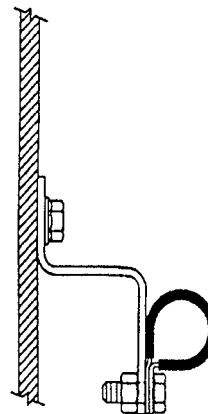

NOT ACCEPTABLE

W3103553

When routing connectors with cable ties, ensure the cable ties do not contact the connector locking tab. Cable ties should also not contact the bare wire.

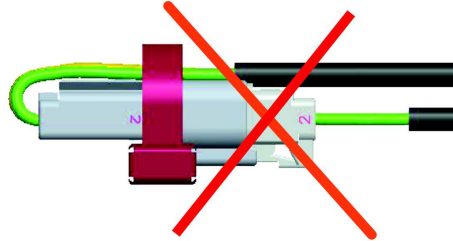
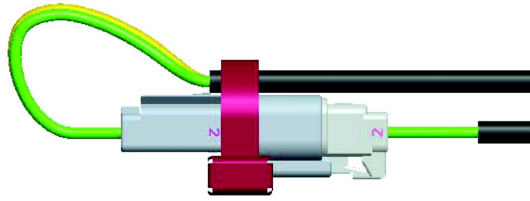

W3104148

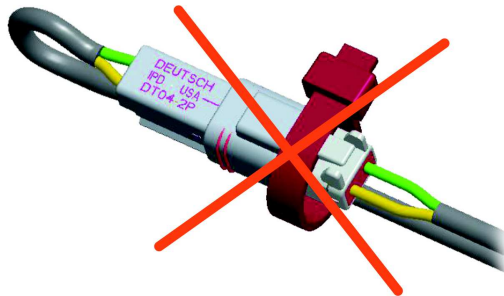
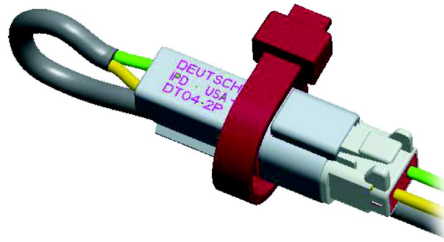

W3104149

Battery Cable Guidelines

The battery cable guidelines prevent electrical interference that can occur from improperly routed cables. In addition, the guidelines prevent cable damage through abrasion.

- 1 Battery cables with standard SAE stranding shall be supported at 16 inches (400 mm) maximum intervals. A separator type cable tie or an independent separator with cable tie may be used between clip points. No relative movement may occur between cables. If two (2) cable separators are used, they are to be installed equidistant from each other and arranged on a straight line, a maximum span between clip points of 24 inches (600 mm) may be used.
- 2 Strain relief clipping shall be provided for the battery and starter motor terminals. The strain relief clip shall be located with no relative motion to the terminals. The strain relief clip should be located close to these terminals and shall be within 20 inch (500 mm) cable length to the starter terminals.
- 3 Grommets shall be installed at points where cables pass through sheet metal or frames.
- 4 Routing shall avoid exposed edges of frame members, abrasive surfaces, and all sharp edges. When routing inside the frame, ensure that no contact with the frame is made with uncovered cables. Uncovered battery cables, external of the battery box, shall be routed independent of all other conduits. Covered cables may be bundled with other similarly covered conduits and air piping with a secured separator. **Do not route with/under fuel lines.**
- 5 Cables should be clipped as close as possible to all cable bends.
- 6 Battery cables shall not be located within 5 inches (130 mm) of engine exhaust related components or other heat sources without heat coverings or heat shielding. Testing shall be performed to determine effects of closer allowances and the use of heat shields. Battery cables should not be installed in any area directly above engine exhaust related components.
- 7 Where cables flex between moving parts, the last supporting clip shall be securely mounted such that relative movement does not promote chaffing.
- 8 Battery cables shall not support any mechanical loads other than their own mass.
- 9 Minimum bend radii of battery cables should be three (3) times the cable diameter for standard SAE strand cable.

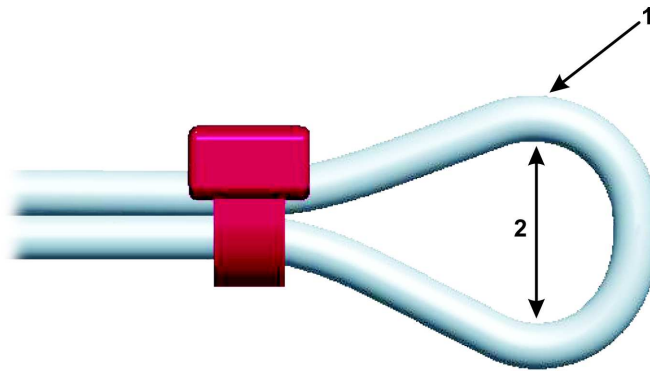

W3104133

1 Tube Diameter

2 Circle Diameter (3 x Tube Diameter)

Battery Guidelines, Continued

- 1 Star washers shall not be used on current path connections including grounds.
- 2 Asphalt type loom shall not be used for battery cable protection applications.
- 3 Battery cables shall not rub each other or surrounding items, but may touch when all items have no independent movement. Uncovered battery cables may not touch each other outside the battery box.
- 4 All exposed exterior to cab circuit ends shall be coated with a dielectric protective coating. Thickness to be 0.13 – 0.3 inches (3.5 – 7 mm) wet, full coverage, 3 inches (76.2 mm) diameter, or shall be completely covered with required inhibitor.
- 5 Clip orientations should be per illustration or installation drawings utilizing compression or heavy duty clip.
- 6 Plastic conduit may be bundled and cable tied with covered battery cables when all items have no independent movement with each other. Battery cables may touch each other, plastic conduit or the battery, inside the battery box.
- 7 Covered battery cables may be securely tied or clamped to each other if no independent movement exists. Cables attached to the same terminal stud may be tied or clamped to each other.
- 8 Battery cable ends at the starter motor posts should be installed and positioned first with the engine harness terminals assembled after. Starter terminals that come with the starter may be first on the starter studs. Terminals shall not be reconfigured or bent.
- 9 Frame bolt placement, adjacent to the battery box, should have the bolt or screw threaded end facing away from the battery box and any related cables. Wrench grip type bolts should not be used in the frame at the battery box area. Non-wrench grip type bolt or screw threaded ends may face toward the battery box only if clip bracketing or shielding shall be provided to prevent any possible cable contact with frame mounted hardware. Bolts that mount the battery box to the frame may be oriented toward the battery box.
- 10 Added abrasion protection should be used where the cable contacts other routed commodities or surfaces with no independent movement such as frame rail surfaces or transmission and engine castings. Polyethylene, polypropylene, nylon conduit and thick wall heat shrink tubing may be used for added abrasion protection.
- 11 Cables should be located to afford protection from road splash, stones, abrasion, grease, oil and fuel. Cables exposed to such conditions should be further protected by either, or a combination of, the use of heavy wall thermoplastic insulated cable, additional tape application, plastic sleeve or conduit.
- 12 Anytime an existing fastener is used to secure a clipping bracket (or any similar device), the fastener shall be re-torqued to the value specified in the original documentation given for the fastener.
- 13 Each exposed exterior circuit end must be coated with a dielectric protective coating. Thickness to be 0.13 – 0.3 inches (3.5 – 7 mm) wet, full coverage, 3 inches (76.2 mm) diameter.
- 14 Do not use box clamps to secure battery cables.
- 15 In addition to Behringer clamps, use double-head tie clamps.

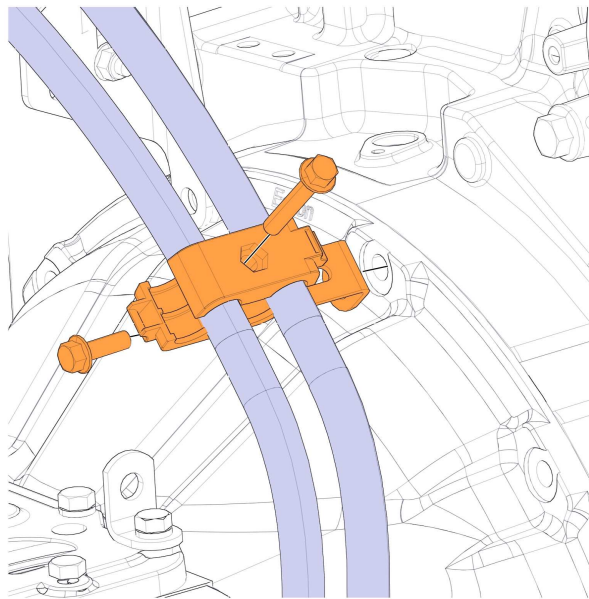

W3077595

Behringer clamps are recommended for securing battery cables to each other.

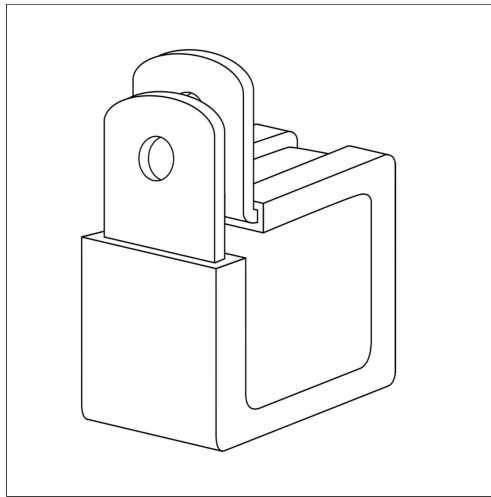

W3105372

Box Clamps (shown above) are NOT to be used for securing battery cables to each other.

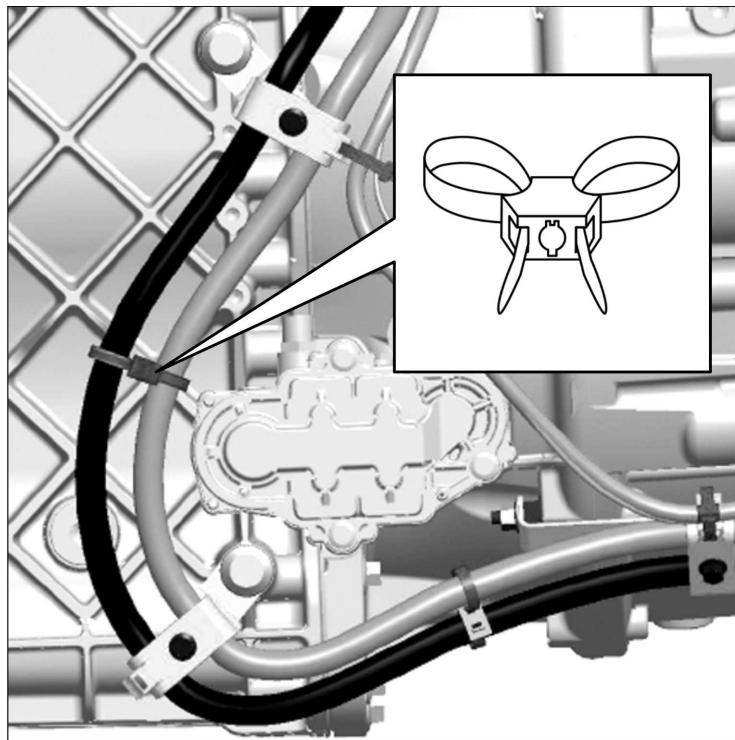

W3105374

Double-head tie clamps may be used to route battery cables.

Ring Terminal Assembly

Assemble terminal carrying the highest current (largest gauge wire) first, then graduate to the smallest gauge up to the fastener. Use a maximum of three (3) terminals per stud (unless otherwise specified on an illustration drawing).

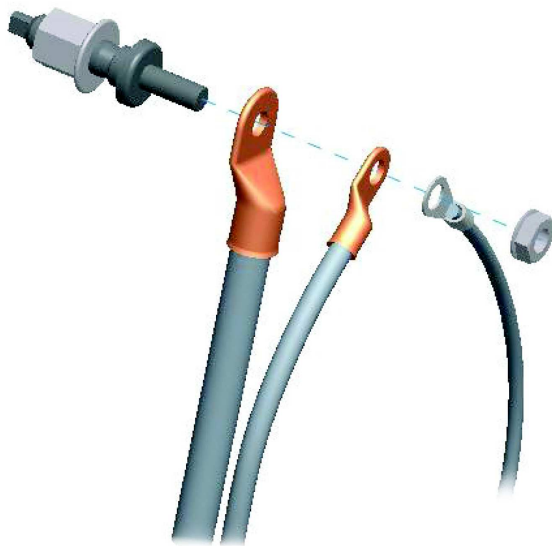

W3104152

When attaching ring terminals with a fastener, tighten the fastener to appropriate torque so that the contact area will touch the terminal at any point, in a full circle that is part of the terminal.

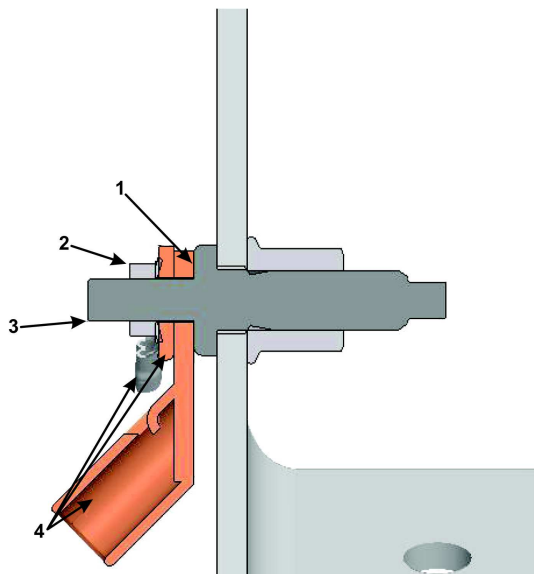

W3104153

- 1 Contact Area
- 2 Fastener
- 3 Stud
- 4 Terminals

When attaching multiple terminals, position the terminals at an angle to allow maximum contact of the terminal surface. Terminals are not allowed to bend other than their natural form. Terminals may be stacked back to back.

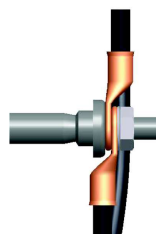
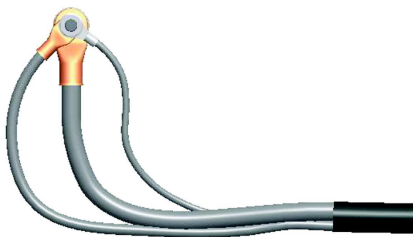

W3104154

Improperly fanned terminals result in unacceptable bends.

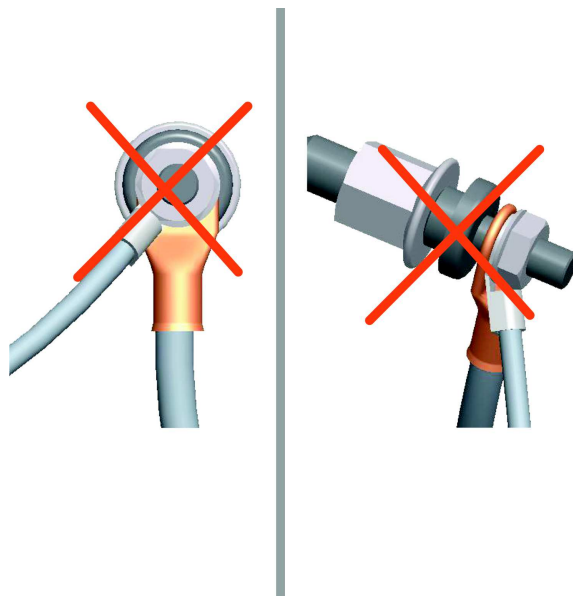

W3104155

Body Builder Preparation Packages

This section lists the available Body Builder Preparation packages for VN and VHD vehicles, and details the content of each package.

Package Level	Variant (Sales Code)	Standard or Optional	Applies to which engine	Contains
Basic	ELCE-PK (L3-A1)	Standard	All	<ul style="list-style-type: none"> 16-way connector located in the cab, between the seats – with body builder power, ground, and REVERSE power; remote stalk PTO speed adjust to VECU, PTO1 I/O (usable w/ VOLVO eng. only). When equipped with Allison Transmission, one additional 16-way conn. with Allison-specific ckts. 3 free circuits in cab <-> chassis harness pass-through
Complete	ELCE-CK (L3-C1)	Optional	VOLVO Only	<p>Contents of ELCE-PK, plus:</p> <ul style="list-style-type: none"> BBM ECU 2 x 16-way connectors pre-wired to BBM ECU body builder I/O circuits

Note: For Factory-Installed Side-Engine PTOs (variants PTES-XXXX, sales codes T9-XX): If a vehicle is ordered with one of the available factory-installed side-engine PTO options (VOLVO engines only), the vehicle will be pre-wired (including dash switch, wiring to VECU, and wiring down to the PTO solenoid). This applies to both VN and VHD vehicles, and is separate from any Body Builder Preparation packages listed above.

Notes

Body Builder Connector Locations (VHD)

VHD

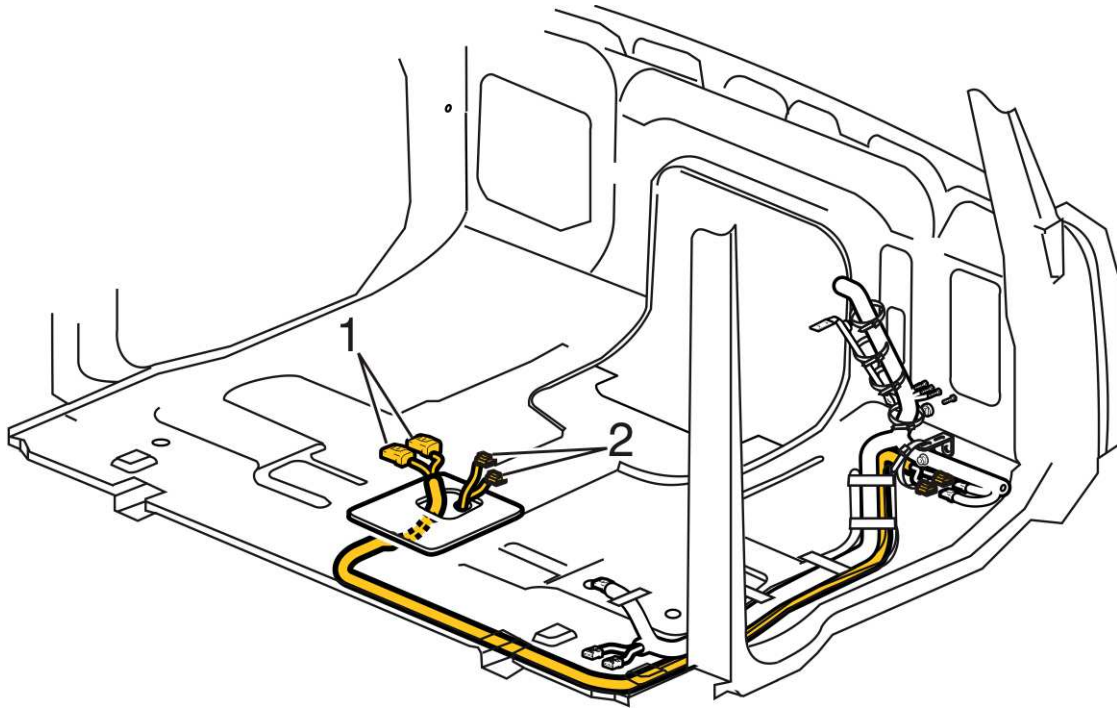

W3037024

Body Builder Prep Kit Wiring and available cover plates

- 1 ELCE-PK connectors - labeled "BB CONN #1 and #2" (#1 is always installed, #1 and #2 if equipped with Allison Transmission)
- 2 ELCE-CK connectors - 2 additional 16-ways - labeled "BB CONN #3 and #4"

Note: For Aftermarket installation without Body Builder hookup use cover plate 85102451.

Plate with Body Builder access hole 20395950.

Notes

Body Builder Harness

Body Builder Harness with Auxiliary Switch Overlay (Dash), VN

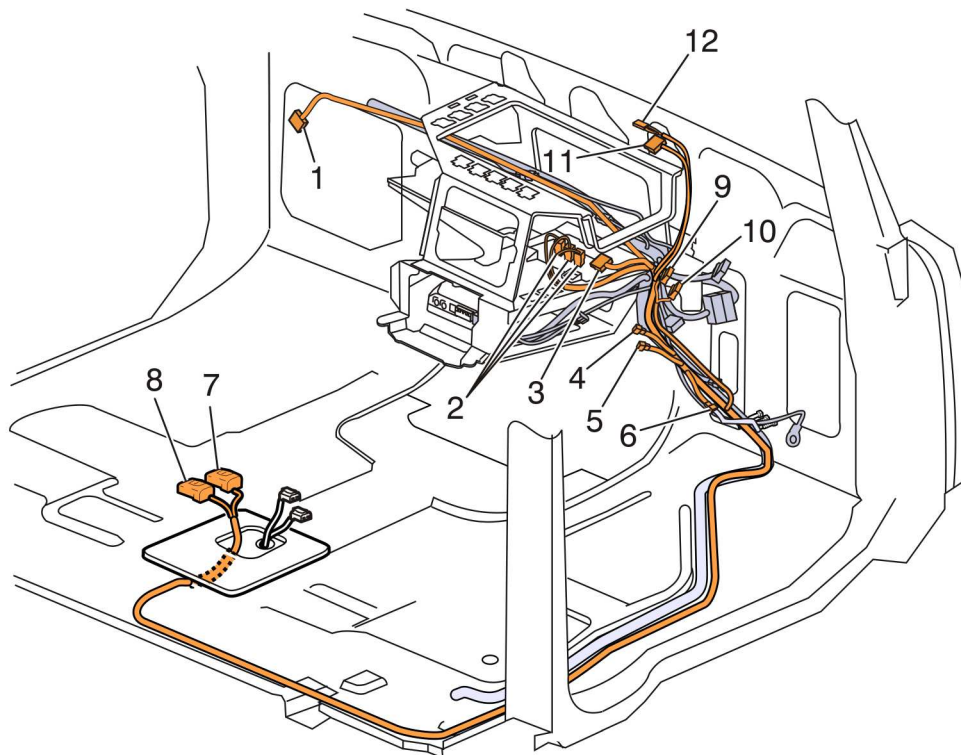

W3035627

- 1 Dual power take off (PTO), Switch
- 2 Body Builder Module (BBM) Electronic Control Unit (ECU)
- 3 Splice Pack (5K141B)
- 4 Main Cab (OPT5)
- 5 Main Cab (OPT1587)
- 6 Main Cab (MCBB)
- 7 Body Builder Connector # 4 (203D.A)
- 8 Body Builder Connector # 3 (203C.A)
- 9 Body Builder Connector # 3 (203C)
- 10 Body Builder Connector # 4 (203D)
- 11 Terminating Resistor (R08A)
- 12 Overlay Options (OPT3)

Body Builder Harness with Auxiliary Switch Overlay (Dash), VHD

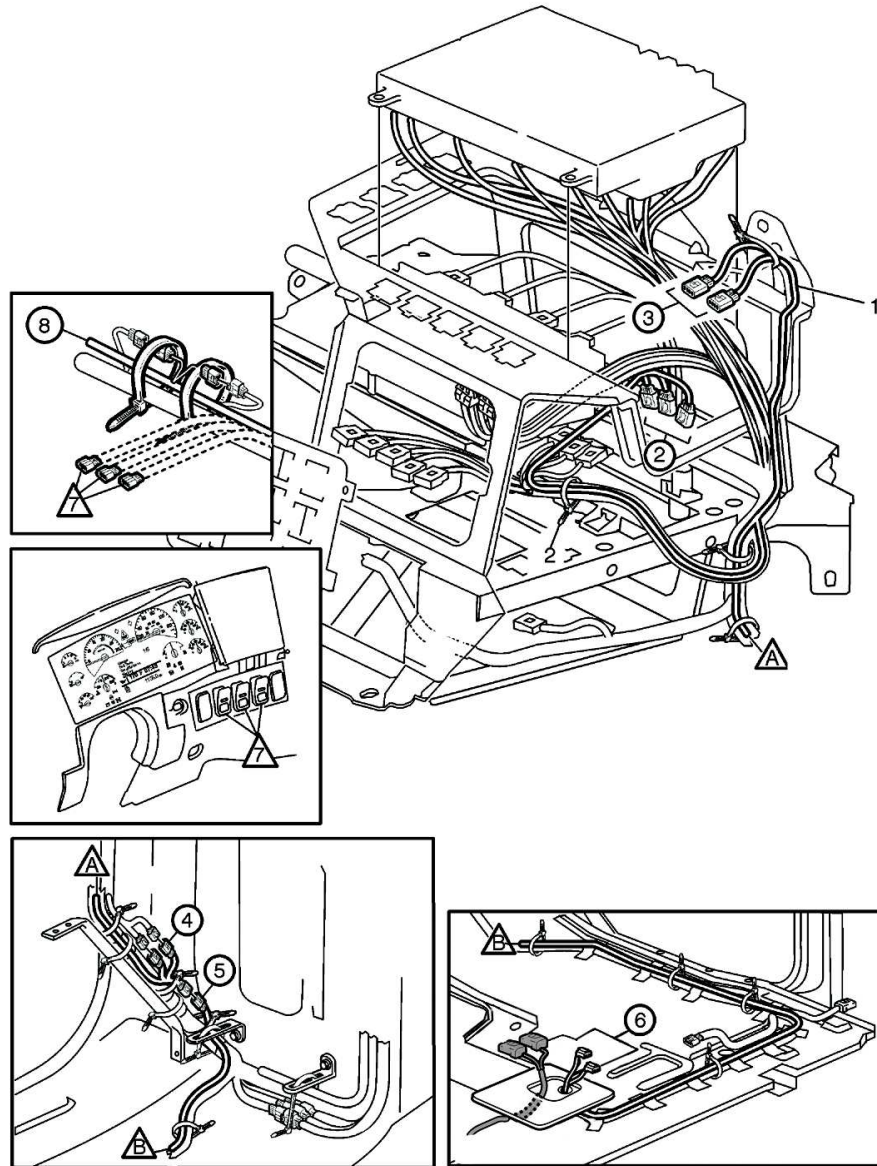

W3118564

- 1 Wiring Harness
- 2 BB Module
- 3 Datalink Option Connector
- 4 Datalink Connection
- 5 Body Builder Module Connection
- 6 Body Builder Module Connection
- 7 Auxiliary Switch Connectors
- 8 To 141A Splice

Body Builder Connections End of Frame

Body Builder connections end of frame provides access to the electrical lighting connections. The circuits provide for separate STOP and TURN signals.

Notes:

- Mating connectors are located in the cab when the truck is delivered.
- If a combined Stop/Turn is required, use the in-line connection point in the rear lighting in-line connector.

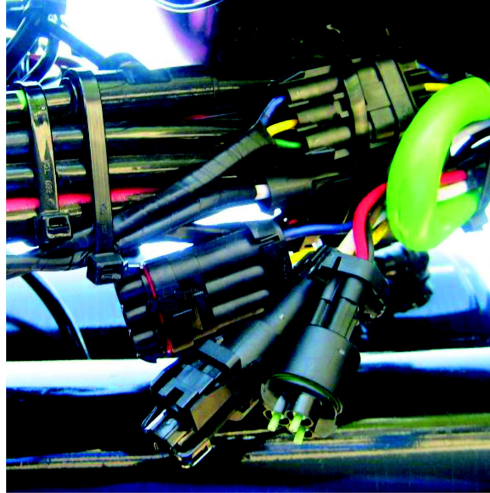

W3118341

Fig. 1 Connectors located at the end of frame

Notes

The connections are grouped into three connectors:

3-Way Metri-Pack 480 Series Connector		
Cavity Assignment	Wire Color	Description
1	Black	Trailer Marker/Clearance lamps
2	Brown	Trailer Tail lamps
3	Red	Stop Lights

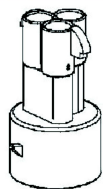

W3118342

3-Way Metri-Pack 630 Series Connector		
Cavity Assignment	Wire Color	Description
A	Yellow	LH Turn Signal Light
B	Green	RH Turn Signal Light
C	Blue	Auxiliary (12V ignition power)

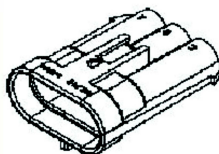

W3118343

1-Way Maxi Connector		
Cavity Assignment	Wire Color	Description
A	White	Ground

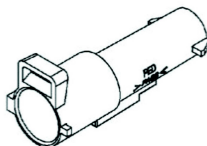

W3118344

Body Builder Pass Through Connectors (VHD)

Three body builder option connectors are in the cab and engine harnesses. These wires provide a pass-through for add-on wiring from the engine compartment to inside the cab.

They are single wires, with plugged connectors, circuit numbers 999A, 999B, and 999C. They are located near the engine pass-through on the engine side, and inside the dash, behind the instrument cluster, on the cab side.

Note: A body builder connector is installed with 14 wires for passing circuits through the cab floor.

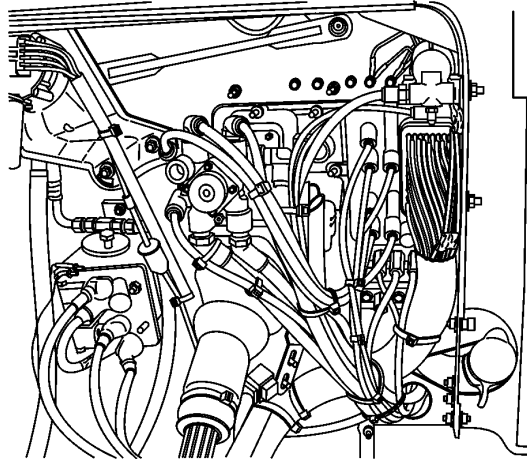

W8003318

Option Connectors, Driver Side Engine Compartment

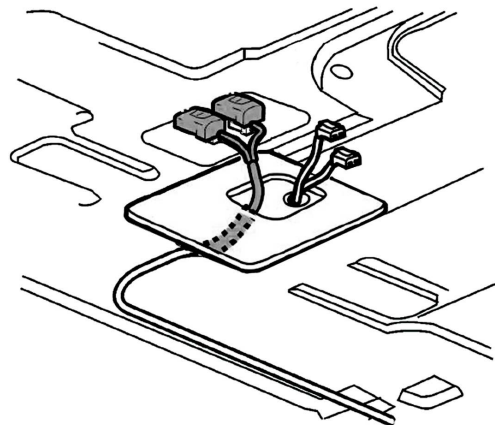

W3118565

Body Builder Connector

VHD Body Builder Connectors

Connector Usage/Gender Information

Connector/Item	Connector Series	Gender On-Vehicle
BB Connector #1 (ELCE-PK)	280-GT, Unsealed 16-way	Female Housing/Female Terminals
BB Connector #2 (ELCE-PK)	280-GT, Unsealed 16-way	Male Housing/Male Terminals
BB Connector #3 (ELCE-CK)	150-GT, Unsealed 16-way	Female Housing/Female Terminals
BB Connector #4 (ELCE-CK)	150-GT, Unsealed 16-way	Male Housing/Male Terminals
Snow Plow Prep.	280-GT, Sealed 10-way	Male Housing/Male Terminals

Cable kit 85148537 is for connectors 1 and 2.
Cable kit 85146080 is for connectors 3 and 4.

Delphi/Packard 150-GT, Unsealed 16-way

Female Housing/Female Terminals

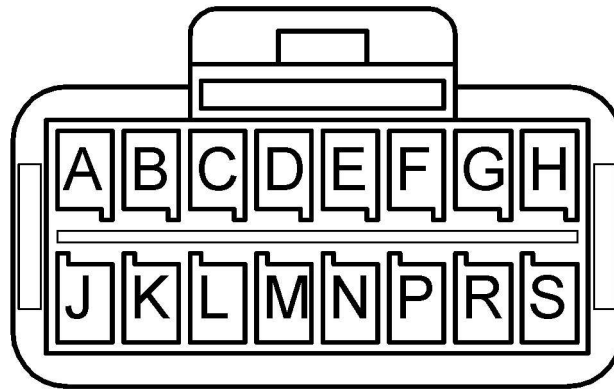

W9000766

Item	Supplier P/N	VOLVO P/N
Housing	15332177	20481359
Terminals-choose by conductor size:		
0.35–0.50 mm ² (0.013-0.019 in ²)	12191811	N/A
0.75–1.00 mm ² (0.029-0.039 in ²)	12191812	N/A
Cable Seals-Not Required		
Cavity Plugs-Not Required		

Male Housing/Male Terminals

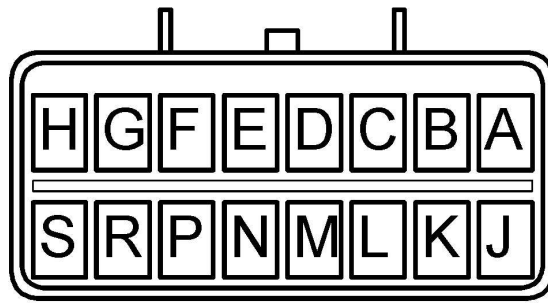

W9000767

Item	Supplier P/N	VOLVO P/N
Housing	15332182	20481361
Terminals-choose by conductor size:		
0.35–0.50 mm ² (0.013-0.019 in ²)	15304701	N/A
0.75–1.00 mm ² (0.029-0.039 in ²)	15304702	N/A
Cable Seals-Not Required		
Cavity Plugs-Not Required		

Delphi/Packard 280-GT, Sealed 10-way

Female Housing/Female Terminals

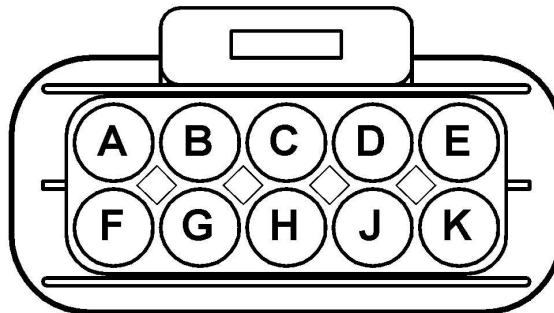

W9000768

Item	Supplier P/N	VOLVO P/N
Housing	15326660	20478205
Terminals-choose by conductor size:		
0.35–0.50 mm ² (0.013-0.019 in ²)	15304718	N/A
0.75–1.00 mm ² (0.029-0.039 in ²)	15304719	N/A
1.50-3.00 mm ² (0.059-0.118 in ²)	15304720	N/A
Cable Seals-choose by insulation O.D.		
1.85-2.25 mm ² (0.072-0.088 in ²)	15366066	N/A
2.50-3.20 mm ² (0.098-0.125 in ²)	15366067	N/A
3.40-3.90 mm ² (0.133-0.153 in ²)	12191235	N/A
Cavity Plugs	15305170	N/A

Male Housing/Male Terminals

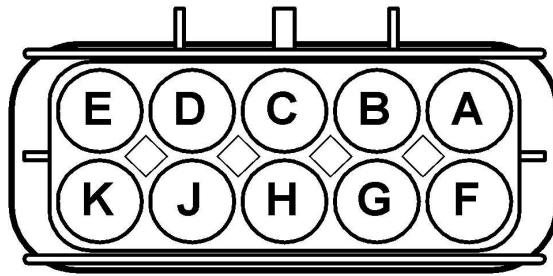

W9000769

Item	Supplier P/N	VOLVO P/N
Housing	15326661	20478204
Terminals-choose by conductor size:		
0.35–0.50 mm ² (0.013-0.019 in ²)	15304730	N/A
0.75–1.00 mm ² (0.029-0.039 in ²)	15304731	N/A
1.50-3.00 mm ² (0.059-0.118 in ²)	15304732	N/A
Cable Seals-choose by insulation O.D.		
1.85-2.25 mm ² (0.072-0.088 in ²)	15366066	N/A
2.50-3.20 mm ² (0.098-0.125 in ²)	15366067	N/A
3.40-3.90 mm ² (0.133-0.153 in ²)	12191235	N/A
Cavity Plugs	15305170	N/A

Delphi/Packard 280-GT, Unsealed 16-way

Female Housing/Female Terminals

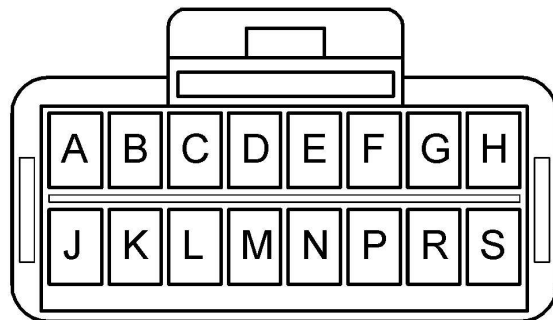

W9000770

Item	Supplier P/N	VOLVO P/N
Housing	15326952	20378995
Terminals-choose by conductor size:		
0.35–0.50 mm ² (0.013-0.019 in ²)	15304711	N/A
0.75–1.00 mm ² (0.029-0.039 in ²)	15304712	N/A
4.00-5.00 mm ² (0.157-0.196 in ²)	15304713	N/A
Cable Seals-Not Required		
Cavity Plugs-Not Required		

Male Housing/Male Terminals

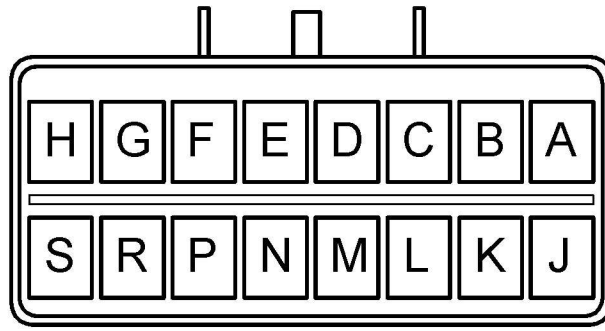

W9000771

Item	Supplier P/N	VOLVO P/N
Housing	15326956	3186494
Terminals-choose by conductor size:		
0.35–0.50 mm ² (0.013-0.019 in ²)	15304723	N/A
0.75–1.00 mm ² (0.029-0.039 in ²)	15304724	N/A
4.00-5.00 mm ² (0.157-0.196 in ²)	15304725	N/A
Cable Seals-Not Required		
Cavity Plugs-Not Required		

Notes

Basic Prep Kit

“Basic” Prep Kit - ELCE-PK (Sales Code: L3-A1)

The basic prep package installed in all VHDs prewires for the most commonly used body builder circuits. It includes fused battery power circuits (both switched and unswitched), ground, Reverse power, and access to the 'stalk' PTO engine speed adjustment circuits.

A 31-way pass through connector in the cab floor is included for passing circuits from inside to outside the cab in a safe, weather-proof manner. In addition, there are two unassigned circuits (MAAA1 and MAAB1) installed in the 102-way pass through from the cab to the engine compartment for body builder use.

If the vehicle is equipped with an Allison Transmission, additional Allison-specific circuits are pre-wired to the body builder connector, as well.

The following tables list the pinout and mating connector information for the 16-way body builder connectors which are part of the ELCE-PK package, located on the cab floor between the seats.

Description of Circuits included in ELCE-PK (Basic Prep Kit)

This is the 'basic' prep kit; Available with all engines. Content is the same for all engines, but differs depending on transmission.

Note: Verify fuse numbers and values with the fuse legend decal installed in your particular vehicle.

Connector #1

Type: 16-way, unsealed Packard GT 280-series (female housing w/ female terminals)

Location: Between driver and passenger seat

Present: Always present with ELCE-PK option (sales code L3-A1)

Pin	Circuit Gen 2 2018	Circuit Gen 1 Pre 2018	Description	Notes
A	X03DH3	X03EA2	Body Builder Ground Return	30A Max.
B	HA10AB	MABA1	Alternator “R” Terminal	N/A
C	F19A1	F43A2	Fused, Unswitched Battery Power	30A “Body Builder” Maxi Fuse; 25A Max.
D	F35A1	F65A1	Fused, Ignition Switched Power	15A “IGN-X” fuse; draw 12A Max.
E	N122A1	N122A1	Allison Defined	N/A
F	N123A1	N123A1	Varies; typically Reduced Eng Load at Stop Input	Typ. Reduced Engine Load at Stop Input
G	F49A4	F62F2	+12V when transmission in REVERSE	Fed via “Body Builder Reverse” fuse; 5A Max.
H	F47A1	F64A1	Fused, Ignition-Switched Power	15A “IGN-Y” fuse; draw 12A Max.
J	F46A1	F29A1	Fused, Ignition-Switched Power	15A “IGN-Z” fuse; draw 12A Max.
K	CAKJ5C5	MAKA1	Stalk PTO engine speed increase	Active High Input
L	CALJ5F5	MALA1	Stalk PTO engine speed decrease	Active High Input
M	F65A3	F34C3	Remote PTO1 Output	Active High Output; 4A Max.
N	CA1AN	F34E3	Remote PTO1 Input/Activation	Active High Input

Pin	Circuit Gen 2 2018	Circuit Gen 1 Pre 2018	Description	Notes
P	N/A	N/A	Empty	
R	N/A	N/A	Empty	
S	N/A	N/A	Empty	

Connector #2

Type: 16-way, unsealed Packard GT 280-series (male housing w/ male terminals)

Location: Between driver and passenger seat

Present: Present with ELCE-PK option (only when Allison transmission installed)

Pin	Circuit Gen 2 2018	Circuit Gen 1 Pre 2018	Description	Notes
A	N/A	N/A	Empty	
B	FR15A87A	NABA1	N.C. contact of relay controlled by A112	Typical PTO Enable Output
C	FR15A87	NACA1	N.O. contact of relay controlled by A112	
D	FR15A30	NADA1	COM contact of relay controlled by A112	
E	FR16A87	NAEA1	N.O. contact of relay controlled by A114	Typical Neutral Indicator for PTO
F	FR16A87A	NAFA1	N.C. contact of relay controlled by A114	
G	FR16A30	NAGA1	COM contact of relay controlled by A114	
H	N103A2	N103A2	Switch Return (Ground)	Use for all Allison-connected active low inputs
J	N117A2	N117A2	Allison defined	Typically AutoNeutral Input
K	N143A1	N143A1	Allison defined	Typically PTO Enable Input
L	XO3BA	XO3BA	Allison ECU Power Ground	Use for ground-connected Allison Outputs
M	N142A1	N142A1	Allison defined	Typically Range Hold Input
N	N101A1	N101A1	Allison defined	Typically Range Inhibit Input
P	N125A1	N125A1	Allison defined	Typically Speedometer Output
R	N113A1	N113A1	Allison defined	Output; varies by application
S	N105A1	N105A1	Allison defined	Typically 'Speed Indicator A' Output

1 The function of all Allison-defined circuits (Axxx) will depend on the chosen Vocational Package. Always refer to Allison Documentation for details.

Note: Allison-Only Circuits numbered "Axxx": Refer to Allison Transmission documentation or Body Builder Transmission service bulletins (using the "Axxx" circuit references) to determine the exact function of each Allison circuit, as they can vary depending upon the vocational package chosen.

Connector/Mating Part Information

Note: Unless otherwise indicated, all part numbers are Delphi / Packard:

Connector/Item	Supplied on vehicle	Mate required to plug into vehicle
Connector #1	Packard 280-GT series (unsealed), 16-way; Female housing & Terminals	Packard 280-GT series (unsealed), 16-way; Male housing & Terminals
Housing Assy:	Packard PN 15326952 VOLVO PN 20378995	Packard PN 15326956 VOLVO PN 3186494
Terminals	Female Terminals, size as required	Male Terminals: Packard 15304723 (0.75 ~ 1.00 mm ²) Packard 15304724 (1.50 ~ 3.00 mm ²) Packard 15304725 (4.00 ~ 5.00 mm ²)
Connector #2	Packard 280-GT series (unsealed), 16-way; Male housing & Terminals	Packard 280-GT series (unsealed), 16-way; Female housing & Terminals
Housing Assy:	Packard PN 15326956 VOLVO PN 3186494	Packard PN 15326952 VOLVO PN 20378995
Terminals:	Male Terminals, size as required	Female Terminals: Packard 15304711 (0.75 ~ 1.00 mm ²) Packard 15304712 (1.50 ~ 3.00 mm ²) Packard 15304713 (4.00 ~ 5.00 mm ²)

Battery and Ignition Feed circuits (F43A1, F65A1, F64A1, and F29A1)

These unswitched and ignition-switched power feeds are provided for body builder's use. Note that each circuit is fused by either a Maxifuse in the Power Module, and/or a minifuse in the standard Fuse and Relay Center. Observe the maximum current capabilities of each circuit.

Note: Verify fuse numbers and values with the fuse legend decal installed in your particular vehicle.

Circuit	Fuse/Fuse Size	Maximum Usable Current
F43A1	F43/10A/30A	25 A (80% of fuse rating)
F65A1	F65/15A	12A
F64A1	F64/15A	12A
F29A1	F29/15A	12A

Note: NEVER increase the size of the fuse beyond what is listed above (or on the Fuse and Relay Center decal). If needed for the application, though, the fuse size may be reduced as dictated by load of the attached equipment.

Special NOTE for the F65A1 circuit (Fuse F65) and F64A1 circuit (Fuse F64)

These circuits are in the electrical 'path' of the PLC4TRUCK signal as it makes its way from the trailer (AUX circuit) to the tractor ABS ECU. Do not use the F65A1 or F64A1 circuits for powering items such as:

- large inductive or capacitive loads such as electric motors or continuously-activated solenoids
- add-on equipment which uses a type of Power Line Carrier (PLC) communication which is not compatible with the PLC4TRUCK signal

Doing so may affect the PLC4TRUCK signal, resulting in a loss of trailer ABS malfunction indication.

Likewise, do not use the F65A1 or F54A1 circuits for powering sensitive communication or weighing equipment which may be affected by the PLC4TRUCK signal.

If you will be connecting to a trailer equipped with the PLC4TRUCK system (basically, any air-braked trailer manufactured after March, 2001), it will be the user's responsibility to ensure that any add-on electrical equipment does not interfere with the trailer ABS malfunction circuit function.

Ground Circuit (X03EA2)

This ground circuit should be used as much as possible for all body builder ground needs. It connects to a ground stud on the vehicle firewall which is a central ground point for all vehicle electrical loads. Note the maximum current capacity of the circuit (dictated by the 6.0mm² conductor size) of 30A.

Reverse Circuit (F63H2)

This is a 10A (max) circuit, live when the transmission is placed into REVERSE gear. It shares a relay (RLY14) and fusing (F63) with the lift-axle logic: when the transmission is not in reverse, the lift axles are allowed to operate; when the transmission is in reverse, circuit F63H2 receives power.

Note: OVERLOADING CIRCUIT F63H2 (and causing F63 to blow) WILL PREVENT PROPER OPERATION OF THE LIFT AXLES.

Notes

Allison Controlled Relays

(NADA1/NACA1/NABA1 and NAEA1/NAFA1/NAGA1) - Allison Transmission Only

Two relays are provided which are controlled by the Allison Transmission circuits N145A1 and N130A1. See the diagram below.

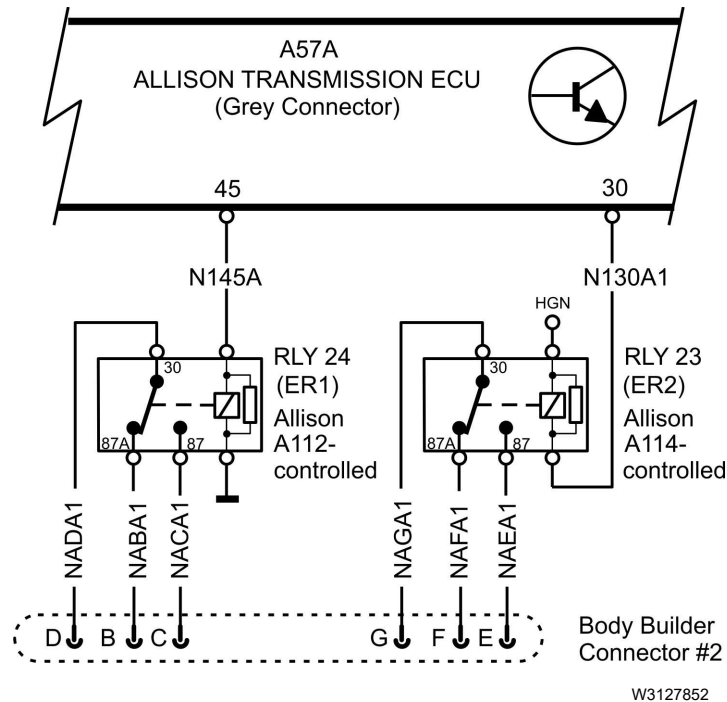

Refer to either Allison Transmission documentation, or the Body Builder Transmission service bulletins, for details on the exact functions of these circuits, as they differ depending upon which vocational package was chosen.

Stalk PTO Engine Speed INC/DEC (MAKA1, MALA1)

These circuits are provided for "remote" adjustment of the engine speed while operating in "stalk PTO" mode. They are connected to relays which operate in parallel with the "SET+" and "SET-" stalk switches, and will allow trimming of the PTO engine speed just as if the in-cab controls were used, except for the added requirement that the vehicle's park brake must be set in order to use these "remote" control circuits.

As with the in-cab stalk PTO mode of operation, the Cruise Control On/Off switch must remain "on". The 'base' PTO set speed should be selected before exiting the cab.

These circuits are usable on both VOLVO and Cummins engines (VNL only), with the same mode of operation that each engine has concerning the in-cab "stalk PTO" operation. Refer to the "Stalk PTO" topic in the "PTO Functions" section of this document.

PTO1 Input/Enable and Output

(F34E3, F34C3) - VOLVO Engine Only

These circuits provide access to the single PTO function of the VECU, and are usable with the VOLVO engine only. If more than one PTO function is required for your application with the VOLVO engine, a body builder module (BBM) ECU will be required - refer to the section on the ELCE-CK prep package.

For a complete description of the PTO1 Input/Enable and Output functions of the VECU, please refer to the "VECU Functions" section of this document.

For all wired-PTO functions with the Cummins engines, it will be necessary to wire directly to the Engine ECU. Refer to the section on the ELCE-EK prep package for available pre-wired circuits, and also to Cummins Engine Company documentation for PTO operation with these engines.

Notes:

- 1 ELCE-PK is standard equipment on all VHDs (truck and tractor), unless specified otherwise.
- 2 ELCE-PK is available with all engines.
- 3 ELCE-PK is available with all transmissions; additional content is included when Allison transmission is specified.
- 4 The wiring for the PTO Relay (RLY07), PTO DASH SWITCH, and "PTO" fusing are present in every VHD; the components themselves are only installed when one of the available PTO-prep options are ordered.
- 5 The function of all Allison Transmission circuits (Axxx) will depend on the chosen Vocational Package; REFER TO ALLISON DOCUMENTATION FOR DETAILS.

Notes

VHD Body Builder Wiring

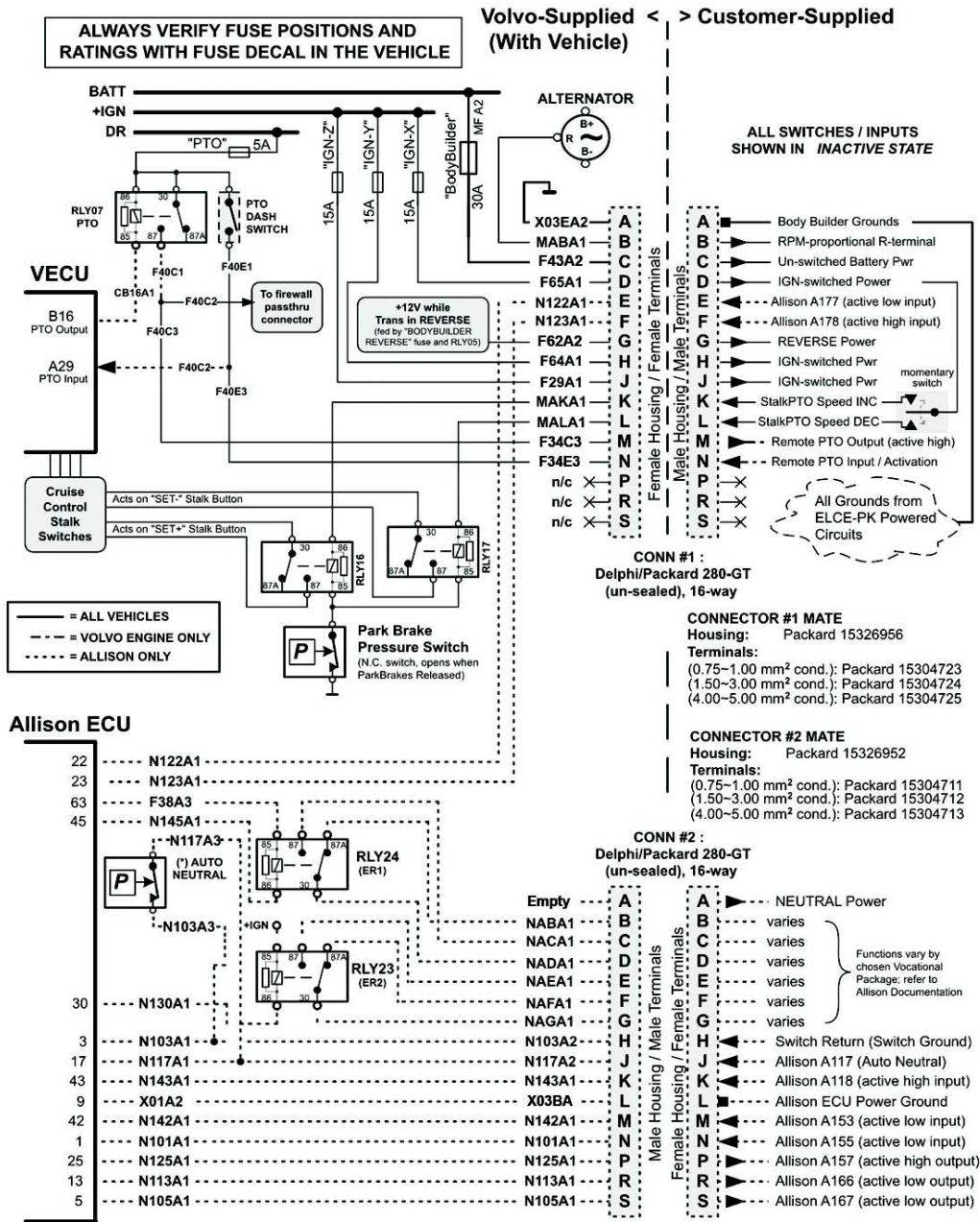

VHD 'BASIC' BODY BUILDER WIRING Variant ELCE-PK, SalesCode L3-A1

W3119185

“Complete” Prep Kit; Including BBM ECU; ELCE-CK (Sales Code: L3-C1)

The "complete" prep kit adds a body builder module (BBM) electronic control unit (ECU) and associated wiring to the standard "basic" prep kit. The ELCE-CK kit is only available with a VOLVO engine.

The following tables list the pinout and mating connector information for the 16-way body builder connectors which are part of the ELCE-CK package, located on the cab floor between the seats.

Description of Circuits Included in ELCE-CK ("Complete" Prep Kit)

In addition to all the circuits listed above in the ELCE-PK package, the ELCE-CK package adds the body builder module (BBM) electronic control unit (ECU), together with the following circuits brought out to two additional connectors located between the seats (same location as -PK package).

Connector #3

Connector # BB-EK

Type: 16-way, unsealed Packard GT 150-series (female housing w/ female terminals)

Location: Between driver and passenger seat

Present: Always present with ELCE-CK option (sales code L3-C1)

Pin	Circuit Gen 2 2018	Circuit Gen 1 Pre 2018	Description	Notes
A	X03DB16	X03EA21	Ground return for all BBM-connected Inputs	
B	MB5A3	MB5A3	+V Power for BBM-connected Switches	Limit to –10 switches per +V output
C	MB19A1	MB19A1	+V Power for BBM-connected Switches	Limit to –10 switches per +V output
D	MA18A2	MA18A2	PTO2 Input/Enable	All PTO inputs are Active High; See VECU (ELCE-PK) for PTO1 Input/Enable
E	MA19A1	MA19A1	PTO3 Input/Enable	
F	MA20A1	MA20A1	PTO4 Input/Enable	
G	MA4A1	MA4A1	PTO1 Engine Speed Control Input	
H	MB21A1	MB21A1	PTO2 Engine Speed Control Input	Active High Inputs
J	MA3A1	MA3A1	PTO3 Engine Speed Control Input	
K	MA5A1	MA5A1	PTO4 Engine Speed Control Input	
L	MB2A1	MB2A1	PTO2 Output	
M	MB3A1	MB3A1	PTO3 Output	Active Low Outputs; limit to 1 Amp per output. See VECU (ELCE-PK) for PTO1 Input/Enable
N	MB4A1	MB4A1	PTO4 Output	
P	MA1A1	MA1A1	Remote PTO Engine Speed DECrement	
R	MA2A1	MA2A1	Remote PTO Engine Speed INCrement	Active High Inputs; act on PTO2-4 only
S	F44BS	N/A	Hood Position Switch	

Connector #4

Connector # BB-EK

Type: 16-way, unsealed Packard GT 150-series (male housing w/ male terminals)

Location: Between driver and passenger seat

Present: Always present with ELCE-CK option (sales code L3-C1)

Pin	Circuit Gen 2 2018	Circuit Gen 1 Pre 2018	Description	Notes
A	MA6A1	MA6A1	Engine Shutdown #1 Input (See Note 1)	Normally Open (N.O.) Switch to +V
B	MA27A1	MA27A1	Engine Shutdown #2 Input (See Note 1)	Normally Closed (N.C.) Switch to Ground
C	MA7A1	MA7A1	Forced Idle/Throttle Interlock Input	Active High Input
D	MA17A1	MA17A1	Engine Speed Limit Input	Active High Input
E	MA25A1	MA25A1	Engine Torque Limit Input	Active Low Input
F	MA26A1	MA26A1	Road Speed Limit Input	Active Low Input
G	MA24A1	MA24A1	PTO Neutral Interlock Input	Active Low Input
H	MA28A1	MA28A1	PTO Low Split Gear Interlock Input	Active Low Input
J	MA29A1	MA29A1	Split Shaft PTO Input	Active High Input
K	MB12A1	MB12A1	Remote Throttle Enable Input	Active Low Input; See Note 2 and 3
L	MB10A1	MB10A1	Remote Throttle V-Ref (5V) Output	See Note 2 and Note 3. Use twisted-trio wiring for these three circuits
M	MB9A1	MB9A1	Remote Throttle Sensor/Signal Input	
N	MB22A1	MB22A1	Remote Throttle Ground Reference	
P	MB28A1	MB28A1	Road Speed Output ("C3" Output)	Active High Output
R	MB16A1	MB16A1	System Warning Output	Active Low Output
S	MB18A1	MB18A1	Databus Triggered Output	Active Low Output

Notes:

- 1 Engine Shutdown Input #1 is always enabled. Do not install a switch at that position if function is not required. Engine Shutdown Input #2 must be enabled in software, and once enabled will shutdown the engine unless ground is present at that input.
- 2 For stationary 2nd Throttle use, it is recommended to add a redundant Park Brake pressure switch in series with the Remote Throttle Enable Input (see schematic). This will allow remote throttle only while the park brake is set. DO NOT tie into the factory-installed Park Brake pressure switch for this purpose.
- 3 For non-stationary 2nd Throttle use, an Accelerator Pedal with Idle Validation Switch (IVS) is required. Circuits for the IVS are not brought out to Body Builder Connector #4. Refer to the BBM ECU section of this document for details on the circuitry needed for a 2nd driving position.

Connector/Mating Part Information

All part numbers shown are Delphi / Packard, unless otherwise noted.

Connector/Item	Supplied on vehicle	Mate required to plug in to Vehicle
Connector #3	Connector #3 Packard 150-GT series (unsealed), 16-way; Female housing & Terminals Packard 150-GT series (unsealed), 16-way; Male housing & Terminals	Packard 150-GT series (unsealed), 16-way; Male housing & Terminals
Housing Assembly	Packard PN 15332177 VOLVO PN 20481359	Packard PN 15332182 VOLVO PN 20481361
Terminals	Packard 12191812 (0.75 ~ 1.00 mm ²)	Packard 15304702 (0.75 ~ 1.00 mm ²) Packard 15304701 (0.35 ~ 0.50 mm ²)
Connector #4	Packard 150-GT series (unsealed), 16-way; Male housing & Terminals	Packard 150-GT series (unsealed), 16-way; Female housing & Terminals
Housing Assembly	Packard PN 15332182 VOLVO PN 20481361	Packard PN 15332177 VOLVO PN 20481359
Terminals	Packard 15304702 (0.75 ~ 1.00 mm ²)	Packard 12191812 (0.75 ~ 1.00 mm ²) Packard 12191811 (0.35 ~ 0.50 mm ²)

Notes:

- 1 ELCE-CK is standard equipment on VHD trucks; optional on VHD tractors.
- 2 ELCE-CK includes all contents of the 'basic' prep (ELCE-PK).
- 3 ELCE-CK is only available with VOLVO engines.
- 4 ELCE-CK is available with all transmissions.

Notes

Volvo-Supplied < | > Customer-Supplied

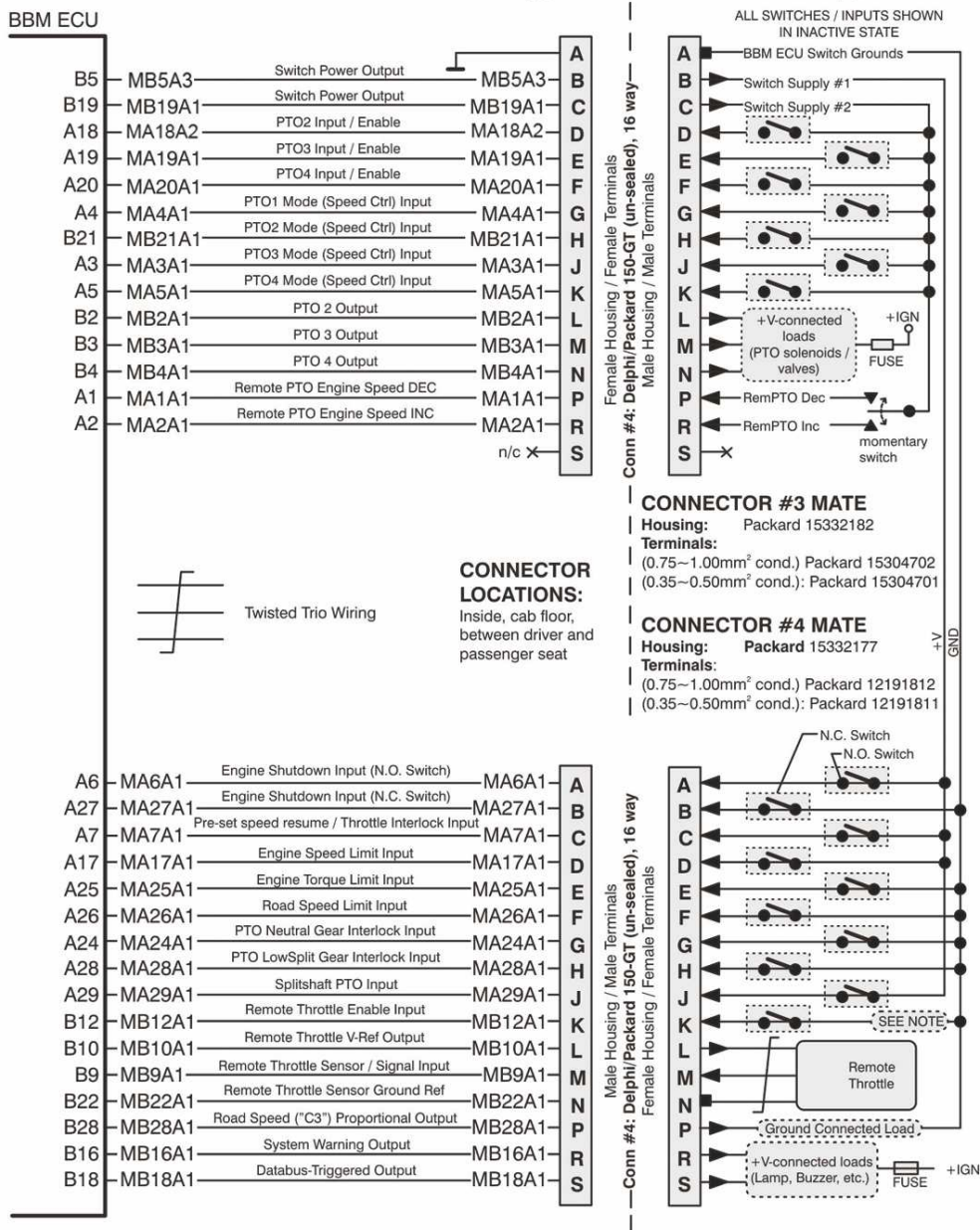

VHD 'BBM ECU' BODY BUILDER WIRING (VECU 4)
 Variant ELCE-CK, SalesCode L3-C1

T3168292

General Information

The VN/VHD contain many Electronic Control Units (ECUs) for operating many of the vehicle's functions. Most ECUs are linked together using one or more databuses for sharing information.

Some ECUs operate independently of each other, but most rely on interaction with other ECUs to properly perform their functions. For example, the Engine Control Module (ECM) depends on the Vehicle ECU (VECU) to supply information on the in-cab controls and switches. Without this information, the engine will not operate properly.

All ECUs use some form of Input and Output devices to perform their functions. These devices may include switches, sensors, solenoids, and relays. **NEVER** tie or splice into a sensor or input device used by an ECU. This could affect the proper operation of the sensor. Likewise, never tie into an output device, which is controlled by an ECU, unless specifically authorized to do so elsewhere in this document.

Data Link Communication

Communication between the different ECUs take place via the two data links: the SAE J1939 data link and the J1587/1708 data link.

The instrument cluster, the engine control module (ECM), the vehicle ECU and the data link connector (DLC) are always included in the system. The system may include other ECUs, depending on engine type and optional equipment.

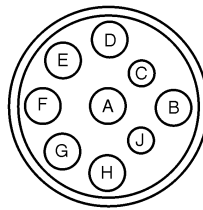
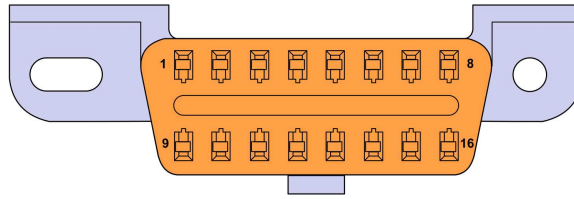

Fig. 2 Diagnostic Connector (Z01)

Pin	Circuit No.	Function
A	X03DA11	Ground
B	F12A1	Fused +Vbatt (Hot at all times)
C	J1939HN4	J1939 Bus (+) (Yellow)
D	J1939LN4	J1939 Bus (-) (Green)
E	AD8A4	ABS
F	J1587HN15	J1708/J1587 Bus (A)
G	J1587LN15	J1708/J1587 Bus (B)
H	AD7A4	ABS
J	F15D5	Ignition Switched +V



W3085011

Fig. 3 16 Pin Diagnostic Connector (OBD 13)

Pin Allocation for the 2013 SAE J1962 16-pin Vehicle Diagnostic Connector (Global Commonality)

16 Pin Diagnostic Connector (OBD 13) Definitions

16 Pin Diagnostic Connector (OBD 13 SAE J1962-Type A Connector)	
PIN	Definition
1	OEM discretionary (assigned as: Key switch – ignition signal for AM tool)
2	Bus positive line of SAE J1850 (Not Used)
3	OEM discretionary (assigned as: SAE J1939-15_CAN_H)
4	Chassis ground
5	Signal ground 6 CAN_H line of ISO
6	CAN_H line of ISO 15765-4
7	K line of ISO 9141-2 and ISO 14230-4 (Not Used)
8	OEM discretionary (Not assigned)
9	OEM discretionary (Not assigned)
10	Bus negative line of SAE J1850 (Not Used)
11	OEM discretionary (assigned as: SAE J1939-15_CAN_L)
12	OEM discretionary (assigned as: SAE J1708 / J1587 positive)
13	OEM discretionary (assigned as: SAE J1708 / J1587 negative)
14	CAN_L line of ISO 15765-4
15	L line of ISO 9141-2 and ISO 14230-4 (Not Used)
16	Battery positive voltage

Supported SAE J1939 Serial Messages

Note: Volvo does not recommend broadcasting on the databus. However, it is known that there are devices on the market which effect an engine speed control.

Volvo broadcasts the following with message and signal definition per SAE J1939-71 Exceptions noted. Dates are build dates rather than model year. Most changes correspond with emissions regulation.

SAE J1939 Messages

SAE J1939 Messages						
PGN	Message Name	Source Address	SPN	Signal Name	Usage	Notes
65198	Air Supply Pressure	23	1087	Service Brake Circuit 1 Air Pressure	Conventional Since 2007	
			1088	Service Brake Circuit 2 Air Pressure		
			46	Pneumatic Supply Pressure		
65269	Ambient Conditions	0, 17, 23	171	Ambient Air Temperature	SA 23 Since 2007 & SA 0,17 since 2010	23 – Sensor Source
			0	108	Barometric Pressure	Since 2007
		172		Engine Air Intake Temperature		
64891	Aftertreatment 1 Service	0	3719	Aftertreatment Diesel Particulate Filter 1 Soot Load Percent	Since 2007	
			3720	Aftertreatment Diesel Particulate Filter 1 AshLoad Percent		
65110	Aftertreatment 1 SCR Reagent Tank 1 Information	0	1761	Aftertreatment 1 SCR Catalyst Tank Level	Since 2010	
			3517	Aftertreatment 1 SCR Catalyst tank Level 2		
			5245	Aftertreatment 1 DEF Tank Low Level Indicator		
			5246	Aftertreatment SCR Operator Inducement Severity		
64946	Aftertreatment 1 Intermediate Gas	0	3251	Aftertreatment 1 Diesel Particulate Filter Differential Pressure	Since 2007	
64947	Aftertreatment 1 Outlet Gas 2	0	3246	Aftertreatment 1 Diesel Particulate Filter Outlet Gas Temperature	Since 2007	

SAE J1939 Messages							
PGN	Message Name	Source Address	SPN	Signal Name	Usage	Notes	
64948	Aftertreatment 1 intake Gas 2	0	3242	Aftertreatment 1 Diesel Particulate Filter Intake Gas Temperature	Since 2007		
65265	Cruise Control/Vehicle Speed	17	84	Wheel Based Vehicle Speed	All		
			86	Cruise Control Set Speed			
			595	Cruise Control Active			
			596	Cruise Control Enable Switch			
			597	Brake Switch			
			598	Clutch Switch			
			599	Cruise Control Set Switch			
			600	Cruise Control Coast (Decelerate) Switch			
			601	Cruise Control Resume Switch			
			602	Cruise Control Accelerate Switch			
			976	PTO Governor State			Reflects engine speed control state not PTO input or output state.
			527	Cruise Control States			
			70	Parking Brake Switch			
57344	Cab Message 1	23	3695	Diesel Particulate Filter Regeneration Inhibit Switch	Since 2007		
			3696	Diesel Particulate Filter Regeneration Force Switch			
			1856	Seat Belt Switch	Since 2010		
65276	Dash Display	23	96	Fuel Level 1	Since 2007		
65226	DM1	0			Since 2007		
64952	DM26	0			Since 2010		
64892	Diesel Particulate Filter Control 1	0	3697	Diesel Particulate Filter Lamp Command	Since 2007		
			3698	Exhaust System High Temperature Lamp Command			

SAE J1939 Messages

PGN	Message Name	Source Address	SPN	Signal Name	Usage	Notes
			3699	Diesel Particulate Filter Passive Regeneration Status		
			3700	Diesel Particulate Filter Active Regeneration Status		
			3701	Diesel Particulate Filter Status		
			3702	Diesel Particulate Filter Active Regeneration Inhibited Status		
			3703	Diesel Particulate Filter Active Regeneration Inhibited Due to Inhibit Switch		
			3706	Diesel Particulate Filter Active Regeneration Inhibited Due to PTO Active		
			3707	Diesel Particulate Filter Active Regeneration Inhibited Due to Accelerator Pedal Off Idle		
			3709	Diesel Particulate Filter Active Regeneration Inhibited Due to Vehicle Speed Above Allowed Speed		
			3710	Diesel Particulate Filter Active Regeneration Inhibited Due to Parking Brake Not Set		
			3711	Diesel Particulate Filter Active Regeneration Inhibited Due to Low Exhaust Gas Temperature		
			3712	Diesel Particulate Filter Active Regeneration Inhibited Due to System Fault Active		
64892 (cont.)	Diesel Particulate Filter Control 1	0	3714	Diesel Particulate Filter Active Regeneration Inhibited Due to Temporary System Lockout	Since 2007	

SAE J1939 Messages						
PGN	Message Name	Source Address	SPN	Signal Name	Usage	Notes
			3715	Diesel Particulate Filter Active Regeneration Inhibited Due to Permanent System Lockout		
			3716	Diesel Particulate Filter Active Regeneration Inhibited Due to Engine Not Warmed Up		
			3698	Exhaust System High Temperature Lamp Command		
61441	Electronic Brake Controller 1	11	561	ASR Engine Control Active	Per ABS type	
			562	ASR Brake Control Active	Per ABS type	
			563	Anti-Lock Braking (ABS) Active		
			1121	EBS Brake Switch	Not Used	
			521	Brake Pedal Position	Not Used	
			575	ABS Off-road Switch	Per ABS type	
			576	ASR Off-road Switch	Per ABS type	
			577	ASR "Hill Holder" Switch	With I-shift	
			1238	Traction Control Override Switch	Per ABS type	
			1243	ABS Fully Operational		
			1438	ABS/EBS Amber Warning Signal (Powered Vehicle)		
			1793	ATC/ASR Information Signal	Per ABS type	
			1481	Source Address of Controlling Device for Brake Control	Per ABS type	
			1836	Trailer ABS Status	Per ABS type	
1792	Tractor-Mounted Trailer ABS Warning Signal	Per ABS type				

SAE J1939 Messages

PGN	Message Name	Source Address	SPN	Signal Name	Usage	Notes
65215	Wheel Speed Information	11	904	Front Axle Speed	All	
			905	Relative Speed; Front Axle, Left Wheel		
			906	Relative Speed; Front Axle, Right Wheel		
			907	Relative Speed; Rear Axle #1, Left Wheel		
			908	Relative Speed; Rear Axle #1, Right Wheel		
			909	Relative Speed; Rear Axle #2, Left Wheel		
			910	Relative Speed; Rear Axle #2, Right Wheel		
64964	Electronic Brake Controller 5	11	2912	Hill Holder Mode	With I-Shift/ mDrive	
61444	Electronic Engine Controller 1	0	899	Engine Torque Mode	All	20 ms fixed rate
			512	Driver's Demand Engine - Percent Torque		
			513	Actual Engine - Percent Torque		
			190	Engine Speed		
			1483	Source Address of Controlling Device for Engine Control		
			1675	Engine Starter Mode		
61443	Electronic Engine Controller 2	0	558		All	from SA 17 with Cummins
			91	Accelerator Pedal Position 1		
			92	Engine Percent Load At Current Speed		
65247	Electronic Engine Controller 3	0	514	Nominal Friction - Percent Torque	All	
64981	Electronic Engine Controller 5		2791	Engine Exhaust Gas Recirculation 1 (EGR1) Valve Control	Since 2007	
			2795	Engine Variable Geometry Turbocharger (VGT) 1 Actuator Position	All	
65263	Engine Fluid Level/ Pressure 1	0	94	Engine Fuel Delivery Pressure	All	

SAE J1939 Messages							
PGN	Message Name	Source Address	SPN	Signal Name	Usage	Notes	
			98	Engine Oil Level			
			100	Engine Oil Pressure			
			101	Engine Crankcase Pressure			
			111	Engine Coolant Level			
65251	Engine Configuration 1	0			30 bytes		
61440	Electronic Retarder Controller 1	0,15	900	Retarder Torque Mode	SA 15 before 2007		
			520	Actual Retarder - Percent Torque			
65262	Engine Temperature 1		110	Engine Coolant Temperature	All		
			174	Engine Fuel Temperature 1			
			175	Engine Oil Temperature 1			
61442	Electronic Transmission Controller 1	3	161	Transmission Input Shaft Speed	Automated transmissions		
			560	Transmission Driveline Engaged			
			573	Transmission Torque Converter Lockup Engaged			
			574	Transmission Shift In Process			
			4816	Transmission Torque Converter Lockup Transition in Process			
			191	Transmission Output Shaft Speed			SA 17 with Cummins
			522	Percent Clutch Slip			
			606	Engine Momentary Overspeed Enable			
			607	Progressive Shift Disable			
			5015	Momentary Engine Maximum Power Enable			
61445	Electronic Transmission Controller 2	3	524	Transmission Selected Gear	Automated transmissions		
			523	Transmission Current Gear			

SAE J1939 Messages						
PGN	Message Name	Source Address	SPN	Signal Name	Usage	Notes
			526	Transmission Actual Gear Ratio		
65134	High Resolution Wheel Speed	11	1592	Front Axle, Left Wheel Speed	Since 2007	
			1593	Front Axle, Right Wheel Speed		
			1594	Rear Axle, Left Wheel Speed		
			1595	Rear Axle, Right Wheel Speed		
65270	Intake/Exhaust Conditions 1	0	173	Engine Exhaust Gas Temperature	Since 2007 SA 23 from 2004-2007	
			102	Engine Intake Manifold #1 Pressure	Since 2007	
			105	Engine Intake Manifold 1 Temperature		
			106	Engine Air Intake Pressure		
			107	Engine Air Filter 1 Differential Pressure		
65266	Fuel Economy (Liquid)	0	183	Engine Fuel Rate	Since 2007	
			184	Engine Instantaneous Fuel Economy		
			185	Engine Average Fuel Economy		
65254	Time/Date	23	959	Seconds	All	
			960	Minutes		UTC/GMT
			961	Hours		UTC/GMT
			962	Day		
			963	Month		
			964	Year		
			1601	Local minute offset		Display clock
			1602	Local hour offset		Display clock
65272	Transmission Fluids 1	3	177	Transmission Oil Temperature	Automated Transmissions	
0	Torque/Speed Control 1	3,11,17,42,230	695	Engine Override Control Mode	By options – engine brake, transmission, etc.	
			898	Engine Requested Speed/Speed Limit		

SAE J1939 Messages						
PGN	Message Name	Source Address	SPN	Signal Name	Usage	Notes
			518	Engine Requested Torque/Torque Limit		
61449	Vehicle Dynamic Stability Control 2	11	1807	Steering Wheel Angle	Trucks with stability control	
			1808	Yaw Rate		
			1809	Lateral Acceleration		
			1810	Longitudinal Acceleration		
			1811	Steering Wheel Turn Counter		
			1812	Steering Wheel Angle Sensor Type		
65103	Vehicle Dynamic Stability Control 1	11	1813	VDC Information Signal	Trucks with stability control	
			1814	VDC Fully Operational		
			1815	VDC Brake Light Request		
			1816	ROP Engine Control Active		
			1817	YC Engine Control Active		
			1818	ROP Brake Control Active		
			1819	YC Brake Control Active		
65217	High Resolution Vehicle Distance	23	917	High Resolution Total Vehicle Distance	All	
			918	High Resolution Trip Distance		
65271	Vehicle Electrical Power 1	0	158	Keyswitch Battery Potential	Since 2007	
65260	Vehicle Identification	0	237	Vehicle Identification Number	Since 2010	
65135	Adaptive Cruise Control	42	1586	Speed of Forward Vehicle	By option	
			1587	Distance to Forward Vehicle		
			1588	Adaptive Cruise Control Set Speed		
			1589	Adaptive Cruise Control Set Distance Mode		
			1590	Adaptive Cruise Control Mode		

SAE J1939 Messages

PGN	Message Name	Source Address	SPN	Signal Name	Usage	Notes
			1796	ACC Distance Alert Signal		
			1797	ACC System Shutoff Warning		
			1798	ACC Target Detected		
			5022	Forward Collision Warning		
65264	Power Takeoff Information	17	980	Engine PTO Governor Enable Switch	Mack	
			984	Engine PTO Governor Set Switch		
256	Transmission Control 1	11	681	Transmission Gear Shift Inhibit Request	By ABS type with Automatic Transmission	
1024	External Brake Request	3	2920	External Acceleration Demand	I-Shift	
			2914	XBR EBI Mode		
			2915	XBR Priority		
			2916	XBR Control Mode		
			3189	XBR Message Counter		
			3188	XBR Message Checksum		

Notes

Supported SAE J1587 Serial Messages

MID 144 (Since 1998)

MID 144 (Since 1998)		
PID	Name	Usage
43	Ignition Switch Status	
44	Attn/Warn Ind Lamps Status	
70	Park Brake SW Status	
71	Idle Shutdown Timer Status	
84	Road Speed	
85	CC Status	
86	CC Set Speed	
89	PTO Status	Bit 1 is any PTO switch. Bit 8 is engine speed control state
91	Acc. Pedal Position	
150	PTO Status, Transmission	
187	PTO Set Speed	
234	Software ID	
237	Vehicle ID Number	Model — Serial
243	Comp. ID	
235	Total Idle Hours	
237	Vehicle ID Number	Model — Serial
243	Comp. ID	

MID 136

MID 136		
PID	Name	Usage
49	ABS Control Status	
84	Road Speed	Until 2007
151	ATC Control Status	
168	Battery Potential	

MID 128 (1998–2013)

MID 128 (1998–2013)		
PID	Name	Usage
44	Attn/Warn Ind Lamps Status	
45	Engine Intake Air Heater Status	By Option
74	Max Road Speed Limit	Actually shows current road speed limit
83	Road Speed Limit Status	
84	Road Speed	

MID 128 (1998–2013)		
PID	Name	Usage
92	Engine Load	
94	Engine Fuel Delivery Pressure	
97	Water in Fuel Indicator	By Option
98	Engine Oil Level	
100	Engine Oil Pressure	
102	Intake Manifold Pressure	
103	Engine Turbocharger Speed	
105	Engine Intake Manifold Temp	
106	Air Inlet Pressure	
108	Barometric Pressure	
110	Engine Coolant Temp.	
111	Engine Coolant Level	
122	Engine Retarder %	
155	Engine Aux. IO Status #1	Fan State
174	Engine Fuel Temperature	
175	Engine Oil Temperature	
183	Engine Fuel Rate	
184	Engine Instantaneous Fuel Economy	
185	Engine Average Fuel Economy	
188	Idle Engine Speed	
190	Engine Speed	
234	Software ID	
235	Total Idle Hours	
237	Vehicle ID Number	Model — Serial
243	Comp. ID	
245	Total Vehicle Distance	
247	Total Engine Hours	
249	Total Engine Rev.	
250	Total Fuel Used	
354	RELATIVE HUMIDITY	Until 2007
411	Engine EXHAUST GAS RECIRCULATION Dif-ferential Pressure	
412	Engine EXHAUST GAS RECIRCULATION Temperature	
439	ExtRange Boost Press #1	
440	ExtRange Boost Press #2	

MID 140 (Since 1998)

MID 140 (Since 1998)		
PID	Name	Usage
77	Forward Rear Drive Axle Temp	By Option
78	Rear Rear Drive Axle Temp	By Option
80	Washer Fluid Level	By Option
96	Fuel Level	
107	Air Filter Diff. Pressure	By Option
116	Brake Appl. Pressure	By Option
117	Brake Primary Pressure	Conventional
118	Brake Secondary Pressure	Conventional
171	AMBIENT AIR TEMPERATURE	
177	Trans. Oil Temp.	Cooler inlet temperature
234	Software ID	
237	Vehicle ID Number	Model — Serial
243	Comp. ID	
245	Total Vehicle Distance	
251	Clock	UTC/GMT
252	Date	

MID 130 (Automated Transmissions until 2013)

MID 130 (Automated Transmissions until 2013)		
PID	Name	Usage
36	Clutch Plate Wear Condition	
44	Attn/Warn Indicator Lamps	
162	Transmission. Range Selected	
163	Transmission Range Attained	
177	Transmission Oil Temp	

Datalink Link Flow

VOLVO Engine

EOBD 2013 and EOBD 2015

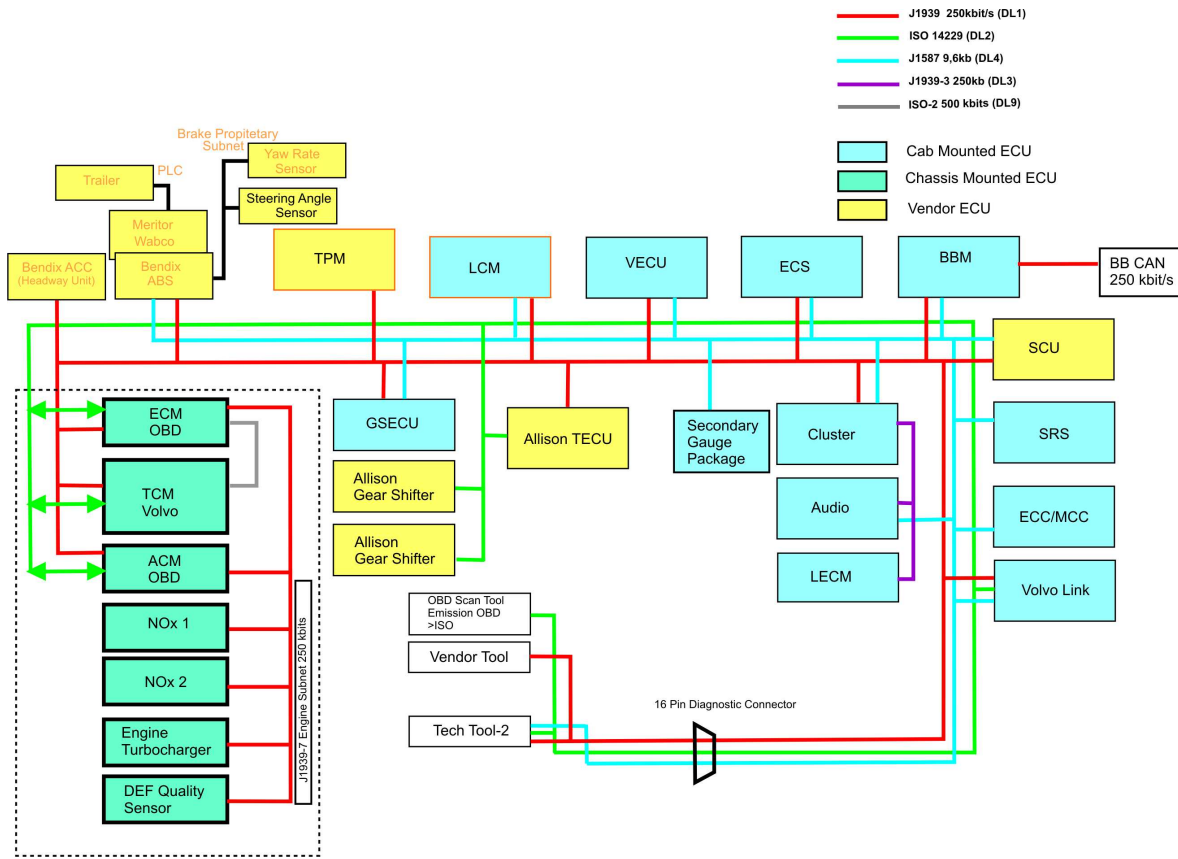

W3081480

Acronym	Description
ABS	Anti-lock Braking System
ACC	Adaptive Cruise Control
ACM	Aftertreatment Control Module
BBM	Body Builder Module
DEF	Diesel Exhaust Fluid
ECC/MCC	Electronic Climate Control/ Manual Climate Control
ECM	Engine Control Module
ECS	Electronically Controlled Suspension
GSECU	Gear Selector Electronic Control Unit
LCM	Light Control Module
LECM	Living Environment Control Module
NOx	Nitrogen Oxide
OBD	On-board Diagnostics
SCU	Satellite Control Unit (Qualcomm)
SRS	Supplemental Restraint System

Acronym	Description
TCM	Transmission Control Module
TECU	Transmission Electronic Control Unit
TPM	Tire Pressure Monitor
VECU	Vehicle Electronic Control Unit

EOBD 2016 and EOBD 2018

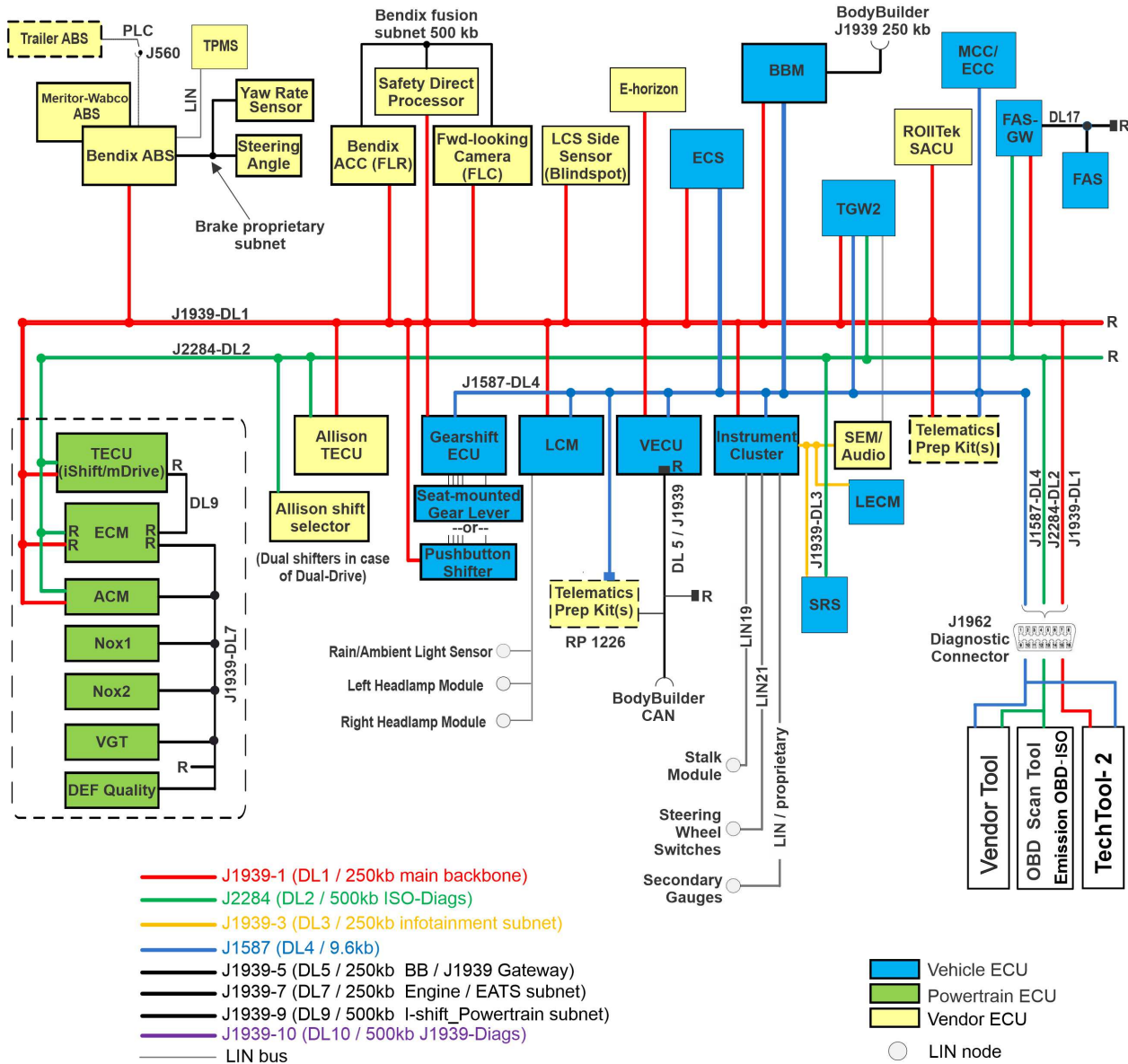

T3173531

Acronym	Description
ABS	Anti-lock Braking System
ACC	Adaptive Cruise Control
ACM	Aftertreatment Control Module
BBM	Body Builder Module
DEF	Diesel Exhaust Fluid

Acronym	Description
DL	Data Link
ECC/MCC	Electronic Climate Control/ Manual Climate Control
ECM	Engine Control Module
ECS	Electronically Controlled Suspension
FAS	Front Axle Steering
FAS-GW	Front Axle Steering- Gateway
FLC	Forward Looking Camera
FLR	Forward Looking Radar
GSECU	Gear Selector Electronic Control Unit
LCM	Light Control Module
LCS	Lane Change System
LECM	Living Environment Control Module
NOx	Nitrogen Oxide
OBD	On-board Diagnostics
SACU	Side Airbag Control Unit
SCU	Satellite Control Unit (Qualcomm)
SEM	Service and Entertain Module
SDP	Safety Direct Process
SRS	Supplemental Restraint System
TCM	Transmission Control Module
TECU	Transmission Electronic Control Unit
TPM	Tire Pressure Monitor
VECU	Vehicle Electronic Control Unit
VGT	Variable Geometry Turbocharger

Note: Not all listed ECUs are available on every vehicle.

EOBD 2013 and EOBD 2015

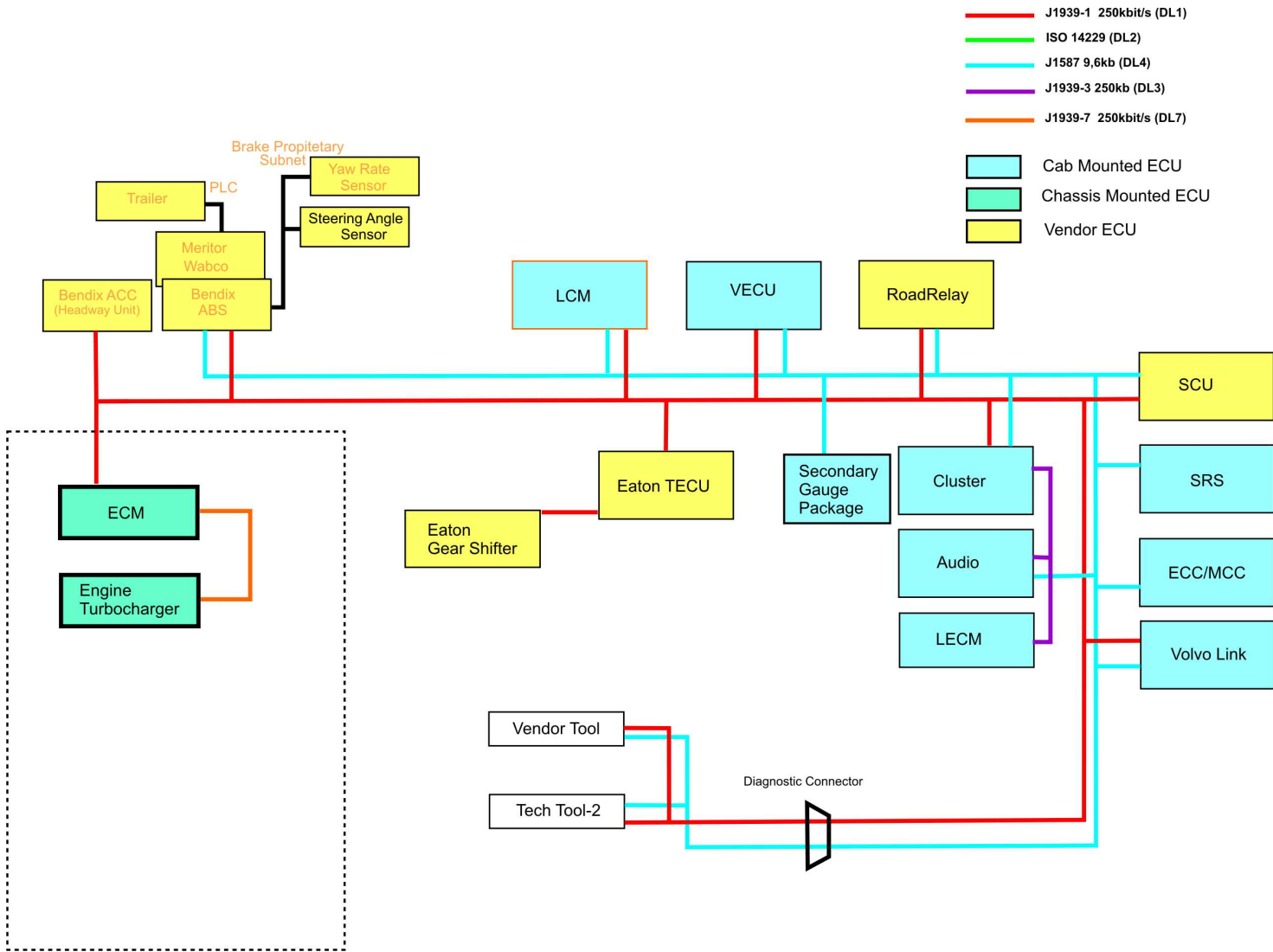

W3081481

Acronym	Description
ABS	Anti-lock Braking System
ACC	Adaptive Cruise Control
ACM	Aftertreatment Control Module
ECC/MCC	Electronic Climate Control/ Manual Climate Control
ECM	Engine Control Module
ECS	Electronically Controlled Suspension
LCM	Light Control Module
LECM	Living Environment Control Module
OBD	On-board Diagnostics
SCU	Satellite Control Unit (Qualcomm)
SRS	Supplemental Restraint System

Acronym	Description
TECU	Transmission Electronic Control Unit
VECU	Vehicle Electronic Control Unit

EOBD 2016 and EOBD 2018

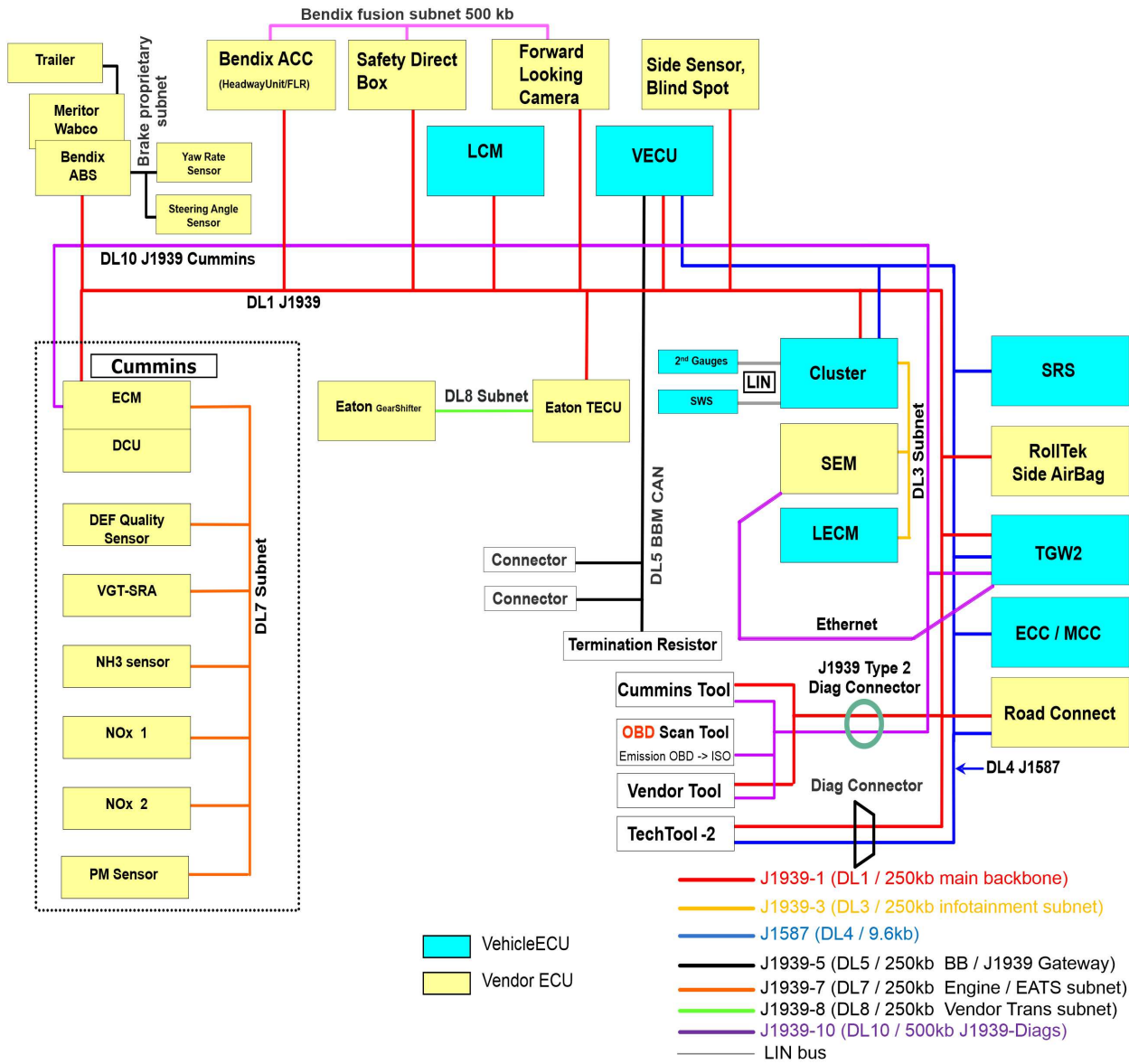

T3173532

Acronym	Description
ABS	Anti-lock Braking System
ACC	Adaptive Cruise Control
ACM	Aftertreatment Control Module
BBM	Body Builder Module
DEF	Diesel Exhaust Fluid
DL	Data Link
ECC/MCC	Electronic Climate Control/ Manual Climate Control

Acronym	Description
ECM	Engine Control Module/Engine management System
ECS	Electronically Controlled Suspension
FLC	Forward Looking Camera
FLR	Forward Looking Radar
GSECU	Gear Selector Electronic Control Unit
LCM	Light Control Module
LCS	Lane Change System
LECM	Living Environment Control Module
NOx	Nitrogen Oxide
OBD	On-board Diagnostics
SACU	Side Airbag Control Unit
SCU	Satellite Control Unit (Qualcomm)
SEM	Service and Entertain Module
SDP	Safety Direct Process
SRS	Supplemental Restraint System
TCM	Transmission Control Module
TECU	Transmission Electronic Control Unit
TPM	Tire Pressure Monitor
VECU	Vehicle Electronic Control Unit
VGT	Variable Geometry Turbocharger

SAE J1939 Control Data Link

The system's **control signals** are sent via this link.

The J1939 link is very fast, operating at 250,000 (250K Baud rate) bits per second. This operating speed allows the system to function more effectively and adapt quickly to changing conditions and vehicle requirements.

The link complies with SAE standards, and consists of two twisted wires: a green wire (CAN_H), and a yellow wire (CAN_L). The twisted wire set [0.89 twists per 25.4 mm (1 inch) or 33 twists per meter (3.28 feet)] is used to protect the link from electrical interference.



CAUTION

No modifications or connections should be made to wires CAN_H (yellow), or CAN_L (green). These wires carry the high-speed communications between the electronic systems in the vehicle. **Any modification, connection to, or damage to these wires can result in the failure of the vehicle's electronic systems.**

Terminating Resistor

Terminating resistors are wired into each end of the J1939 data link. One is located near the Fuse/Relay Center in the cab and the other near the ECM. On Volvo engines, the terminating resistor at the ECM end is located inside the ECM.

Only two terminating resistors are used in a vehicle. Never install three in one truck. If more than two terminating resistors exist in the J1939 circuit, damage to the ECU electronics can occur over time. You can easily check to see if you have two resistors by measuring the resistance between circuits CAN_H and CAN_L, at the diagnostic connector, with the ignition OFF. The correct resistance is 50 - 70 Ω .

The purpose of these resistors is to prevent data link signal reflections. They must remain connected for the system to function properly.

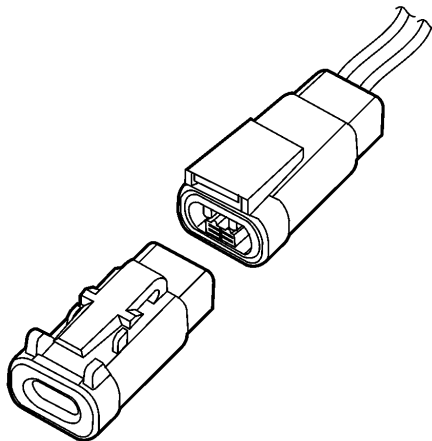

W3005518

Fig. 4 J1939 Terminating Resistor

SAE J1587/1708 Information Data Link

Information and diagnostic signals are sent via this link. The link also functions as a “backup” should the J1939 control data link fail to function for any reason.

SAE J1708 is a standard that specifies hardware and a databus speed of 9600 bits per second (9.6K Baud rate). SAE J1587 is a protocol that provides a standard method for exchanging information between microprocessors.

The J1587 link consists of two wires [(SAE J1708 (A)) and (SAE J1708 (B))] that are twisted 1 twist per 25.4 mm (1 inch) or 40 twists per meter (3.28 feet). The twisted-pair wires are to protect the link against electrical interference.



CAUTION

If a circuit must be added to the electrical system, and will carry high currents or frequencies, route it in a location **AWAY** from wires (SAE J1708 (A)) and (SAE J1708 (B)) to prevent mutual inductance from interfering with data link functions.



CAUTION

Wires (SAE J1708 (A)) and (SAE J1708 (B)) **MUST NOT** be cut or spliced for any connections. These wires are used for the transmission of data for diagnostic messages and gauges. Modifying this circuit can cause these functions to fail.

ISO 14229 Data Link

Note: ISO 14229 only applies to vehicles with VOLVO engines.

ISO 14229 is the Powertrain control link. The ISO is used for programming between the ECM, ACM and TCM. It is used primarily to transmit control signals that are shared between other stand alone modules. The information on the ISO 14229 control link is used for control functions. Fault messages or diagnostic information also transmits across this link. These control signals may be for engine, transmission and aftertreatment ECUs.

The ISO 14229 operates at 500,000 (500K Baud rate) bits per second. This higher speed allows the system to operate at a faster sampling rate and higher resolution, thus being more capable of improving programming and diagnostic time.

The ISO 14229 data link consists of a pair of 18 gauge un-shielded twisted wires. The designations of the networks are CAN_H and CAN_L. The designations of the individual wires are DL2H and DL2L which are both white with orange stripes. The nominal rate of twist required is 40 twists per meter (3.28 feet). This twist helps protect against electrical interference.

The ISO 14229 data link is electrically terminated at each end with a load resistor, which is commonly referred to as a termination resistor. Each ISO 14229 network has two termination resistors associated with it. Only two termination resistors are allowed within a network. The termination resistor can be located externally as part of the wiring harness, or integrated internally in the ECU/ECM. Any ECU/ECM that does not contain the termination resistor is referred to as a Type I, and an ECU/ECM that contains the termination resistor is referred to as a TYPE II. The correct number of termination resistors can be easily checked by measuring the resistance across cavities 3 and 11 for the 16 pin diagnostic connector. The correct resistance is 50 – 70 ohms. The terminating resistors should each have a resistance of 110 – 130 ohms when tested individually.

Note: It is important to remember which control units the vehicle is equipped with and which fault codes are stored in each control unit.

Diagnostic Connector

The diagnostic connector is located in the driver's side kick panel. The diagnostic connector is connected to the ISO information link and gives the system a way to communicate with an external PC or diagnostic tool.

With a PC or diagnostic tool connected, error codes can be read from all the control units. This is important in fault tracing to carry out basic checks of all the vital parts of the vehicle's electronics.

Some programming can also be done via the diagnostic connector.

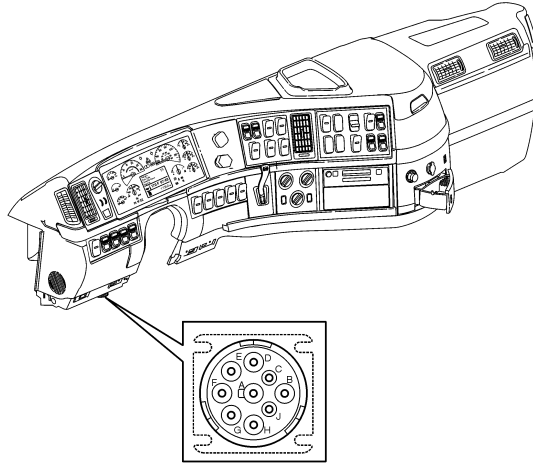
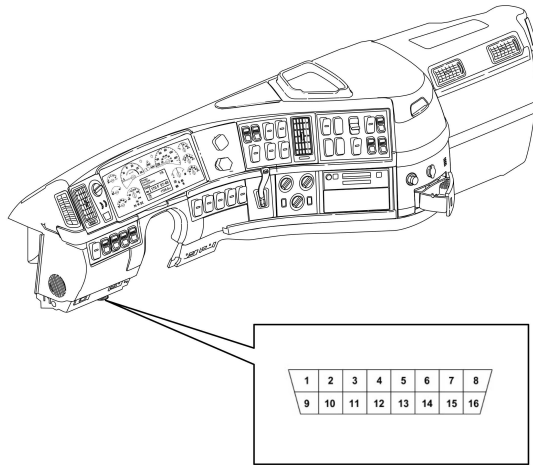
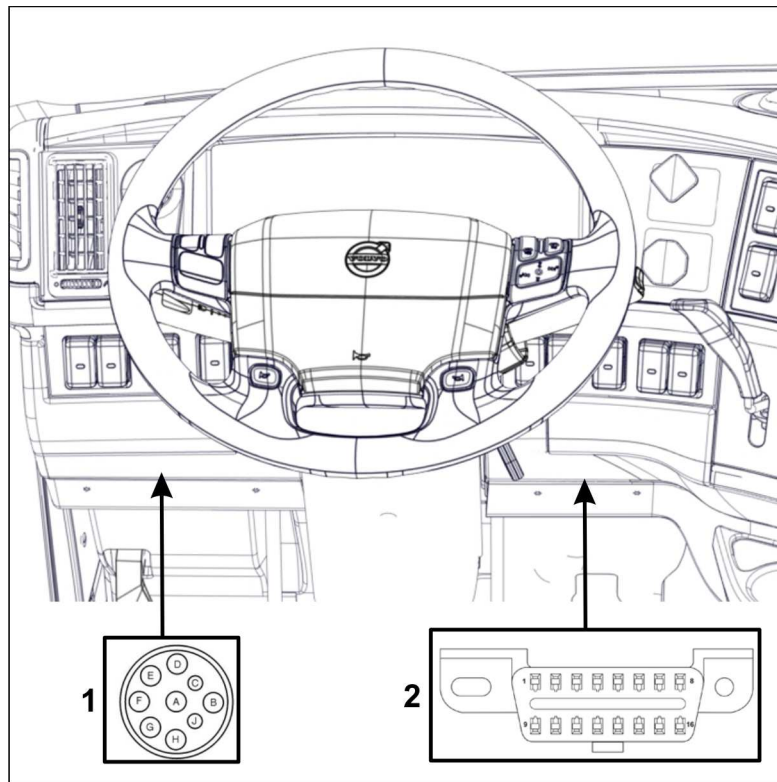

Fig. 5 Diagnostic Connector (9 Pin)



W3077811

Fig. 6 Diagnostic Connector (16 Pin)



W3108714

Fig. 7 GHG 2017 with Cummins Engine

- 1 Diagnostic Connector (9 Pin)
- 2 Diagnostic Connector (16 Pin)

Vehicle Accessory Connector (RP1226)

The purpose of vehicle accessory connector (TMC RP1226) is to connect the vendor device to the vehicle.

This connector provides an intuitive and quality assured interface between the vehicle and vendor device.

Location of the connectors

An accessory connector is located under the instrument panel. The connector is used to connect the aftermarket Fleet Management devices. Only one vendor device is allowed to connect with the connector.

Note: The vendor device must not have an internal termination resistor.

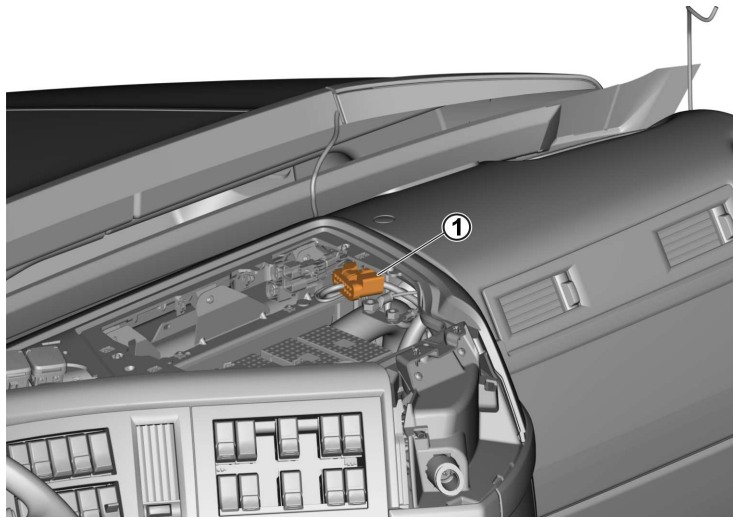

T0169408

1 Vehicle Accessory Connector (TMC RP1226)

TMC RP1226 Connector

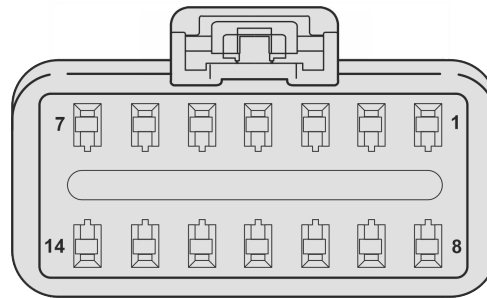

T3159520

Pin numbers	Description
1	+12 V After battery switch (10 A shared)
2	CAN-1 High
3	—
4	—
5	—
6	J1708A
7	+12 V After ignition (10 A shared)
8	Ground
9	CAN-1 Low
10	—
11	—
12	—
13	J1708B
14	+12 V Battery (10 A shared)

Mating Connector

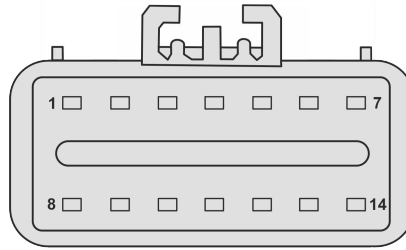

T3159741

Description	Part number
Drive cam harness	23805104

TMC RP1226 Wiring Schematics

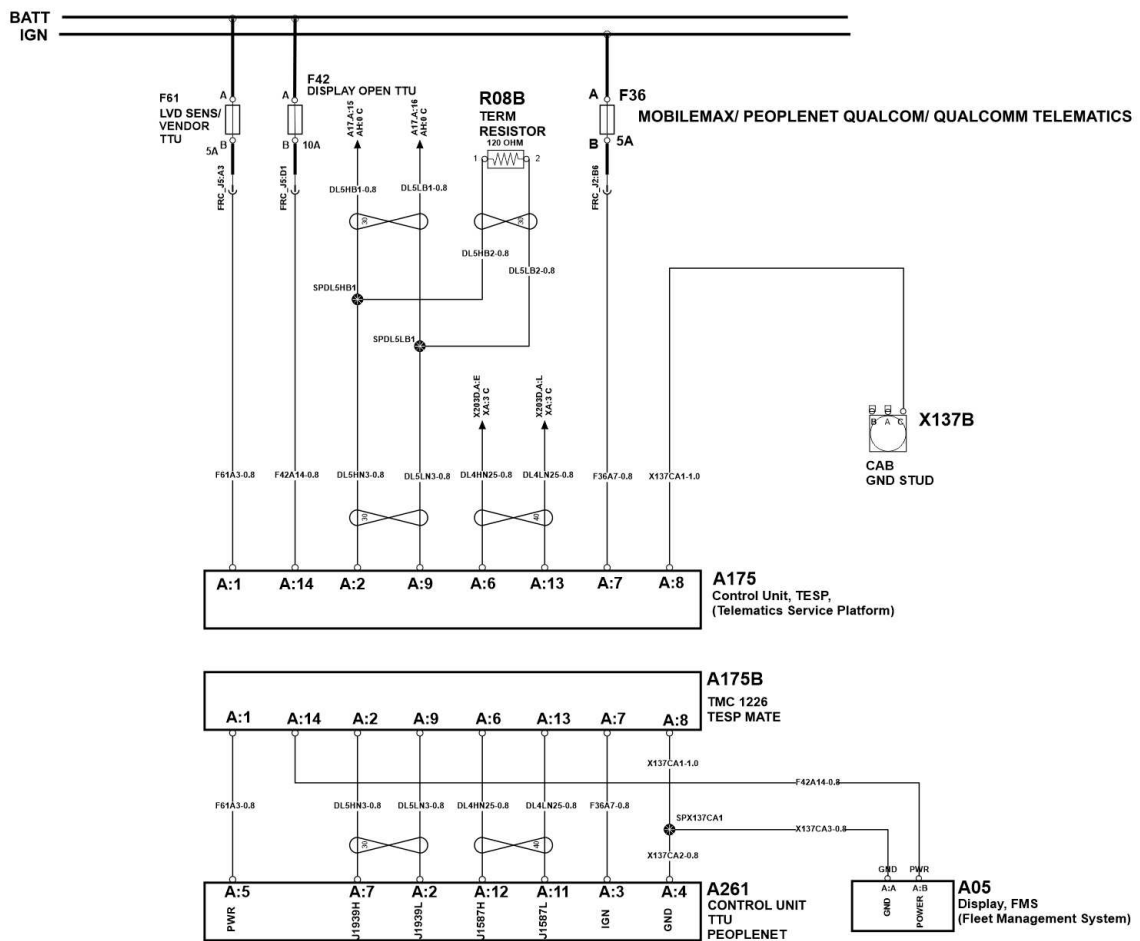

T3169445

Notes



ECU Functions and Parameter Programming

This section lists functions which will be of interest to Body Builders and others needing to modify certain (programmable) aspects of the ECUs. If an ECU is not included in this section, it is because there are no adjustable functions which can be modified in the field.

Not all functions or parameters listed in this document may apply to the vehicle you have, because of running changes and improvements made over time. Using each component's Main Software part number, the Premium Tech Tool (PTT) knows which parameters apply, and show only those which are adjustable for that particular vehicle.

Whenever working on the electrical system of the vehicle, certain ECUs such as the Airbag (SRS) ECU, need special handling to avoid damage. Refer to the appropriate ECU sections, and to the individual ECU service manual, for the appropriate precautions.

All ECUs use some form of Input and Output devices to perform their functions. These devices may include switches, sensors, solenoids, and relays. DO NOT tie or splice into an existing sensor or input device used by an ECU, or else proper operation of that sensor may be affected. Likewise, DO NOT tie into an Output device which is controlled by an ECU unless specifically authorized to do so in this document.

Always observe proper Electrostatic Discharge (ESD) precautions while working around the ECUs, as outlined in the "Service Procedures" portion of this document.

The Inputs and Outputs (I/O) of the ECUs follow a certain "logic" which are important to understand when interfacing to the ECUs. The following information explains the terminology used in this document:

Input/Output Type	Definition
Active High (or Active +V)	<p>This input is typically configured with a switch wired to + Voltage. The input has two states; either floating (switch open), or +V (switch closed). The input is considered active when +V is applied.</p> <div data-bbox="737 1058 1313 1299" data-label="Diagram"> </div> <p style="text-align: right; font-size: small;">W9000629</p>
Active Low (or Active ground)	<p>This input is typically configured with a switch wired to ground. The input has two states; either floating (switch open), or grounded (switch closed). The input is considered active when grounded.</p> <div data-bbox="737 1518 1313 1759" data-label="Diagram"> </div> <p style="text-align: right; font-size: small;">W9000630</p>
NC switch to +V	<p>This input type typically has a Normally Closed (NC) switch contact connected to +V. The input becomes active when the switch is opened or the circuit is otherwise broken.</p>

Input/Output Type	Definition
	<div data-bbox="662 149 1239 390" data-label="Diagram"> </div> <p data-bbox="1170 428 1252 447">W9000631</p>
NC switch to ground	<p data-bbox="440 478 1463 537">This input type typically has a Normally Closed (NC) switch contact connected to the ground. The input becomes active when the switch is opened or the circuit is otherwise broken.</p> <div data-bbox="662 575 1239 816" data-label="Diagram"> </div> <p data-bbox="1170 850 1252 869">W9000632</p>

I/O Type	Definition
OUTPUTS	
Active High	<p data-bbox="448 1016 1455 1075">This output sources current (the voltage goes high) when active. The other side of the load or controlled device is connected to ground.</p> <div data-bbox="662 1115 1239 1356" data-label="Diagram"> </div> <p data-bbox="1170 1390 1252 1409">W9000633</p>
Active Low	<p data-bbox="440 1440 1463 1499">This output sinks current (the voltage goes low, usually to the ground) when active. The other side of the load controlled device must be connected to +V.</p> <div data-bbox="662 1535 1239 1776" data-label="Diagram"> </div> <p data-bbox="1170 1810 1252 1829">W9000634</p>

Many of the functions on today's vehicles are shared among different ECUs. Use the following guide to help decide which ECU controls which functions:

Feature/Function	With Volvo engine, adjust in:	With Cummins engine, adjust in:
Cruise Control Parameters	VECU	ECM
Engine Brake Levels	(not adjustable)	VECU
Gear down Protection	ECM	ECM
Idle Shutdown Operation	VECU	ECM
Low Idle Speed Adjustment	VECU	VECU and ECM
PTO Programming	VECU and BBM ECU	ECM
Road Speed Limit(s)	ECM	ECM
All Other Body Builder Related Functions (e.g., switchable engine speed & torque limits, remote throttle activation, etc.)	BBM ECU	ECM

Volvo Engine Control Module (ECM)

Starting with OBD13 all engines have P-Codes for parameters.

OBD 2013 Engine Codes	
Electronics Version 3 Parameter Code	Electronics Version 3 + Equivalent DOID
DN	P1IP6
9D	P1I09
DP	P1AOC
AJ	P1AIO
DV	P1AOD
9G	P1I07
9H	P1I08
ATJ-ATO	P1AM4-P1AM9
BNQ	P1IDB
AU	P1ANA
AZQ	P1I03
AZS	P1I06
AZR	P1I05
ADZ	P1I0G
AEA	P1I0L
ADV	P1I53
AEB	P1I0P
BTR	P1I0M
ADX	P1I0H

OBD 2013 Engine Codes	
Electronics Version 3 Parameter Code	Electronics Version 3 + Equivalent DOID
ADY	P110J
AZN	P1HTZ

The following parameters and features are adjustable in the Volvo engine; note that some 'engine' functions such as Idle Shutdown, Cruise Control, and PTO settings are actually contained in the Vehicle ECU (VECU) and/or BBM ECU.

Parameter Name	Code	Default Value	Adjustment Range	Description
Customer Data, Fleet ID	DN	N/A	13 character alphanumeric	Fleet ID can also be viewed/adjusted via the Instrument Cluster.
Road Speed Limit (RSL), mandated by law	9D	140 km/h (87 mph)	DP ~ 140 km/h (DP ~ 87 mph)	Maximum permissible vehicle speed (factory-programmed); required by some jurisdictions/regions.
Road Speed Limit (RSL), owner/customer	DP	110 km/h (68 mph)	30 ~ 9D km/h (18 ~ 9D mph)	Customer-selectable maximum vehicle speed (road speed limit).
Differential Road Speed Limit (RSL) enable/disable	AJ	No	Yes/No	Gear Down Protection-Allows imposing a different (lower) road speed limit unless operating in 'top' gear. If, 'Yes', also specify DV, 9H, and 9G .
Differential Road Speed Limit (RSL) Vehicle Speed	DV	DP-8 km/h (DP-5 mph)	30 ~ DP km/h (18 ~ DP mph)	If the parameter AJ is enabled, this regulates the Vehicle Speed Limit when not in top gear.
Gear Ratio-Diff. RSL-Highest Gear	9G	74% (0.74)	30 ~ 130 %, (0.30 ~ 1.30)	Gear ratio for the top transmission gear; programmed as a percentage. (0.74:1 ratio = 0.74 = 74%). Maximum value of 9H
Gear Ratio-Diff. RSL-2nd Highest Gear	9H	100% (1.00)	30% ~ 150% (0.30 ~ 1.50)	Gear ratio for the gear one below 'top' gear; programmed as a percentage. (1:1 ratio = 1.00 = 100%). Minimum value of 9G
Injector Calibration Values	ATJ-ATO	Each unit injector is assigned a calibration number at the time of manufacturing. If any injectors are replaced in the field, these values need to be updated with the value shown on the replacement injector label. DO NOT alter these values unless instructed by the applicable service literature.		
Max. Engine RPM at Speed Sensor Error	BNQ	Varies	Varies	Maximum allowed engine speed when a Vehicle Speed Sensor (VSS) error is present.
Max. Engine RPM, Stationary	AU	Varies	Varies	Maximum engine speed with zero vehicle speed
Max. Engine RPM, High Gears (Governed ESPD)	AZQ	Varies	1900, 2000, or 2100 RPM	Governed Engine Speed which will apply when operating the transmission in the 'top gears', as defined by gear ratio parameters AZS and AZR.
Max. Engine RPM-Gear ratio for limited max. ESPD	AZS	360% (3.60)	100% ~ 500% (1.00 ~ 5.00)	Transmission Gear Ratio for the gear where governed engine speed is applied. Expressed as a percentage, 3.6:1 = 3.60 = 360%. Max. value of AZR
Max. Engine RPM-Gear Ratio Setting (Lowest Gear)	AZR	340% (3.40)	100% ~ 500% (1.00 ~ 5.00)	Transmission Gear Ratio for the one gear below the ratio setting in parameter AZS. Expressed as a percentage, minimum value of AZS.

Parameter Name	Code	Default Value	Adjustment Range	Description
Perf. Bonus-Enable/ Disable	ADZ	Selected at time of order	Yes/No	Selects whether the Performance Bonus feature is enabled. If 'Yes' then also specify AEA, ADV, AEB, BTR, ADX and ADY.
Perf. Bonus-Rewarded Parameters	AEA	Varies	Varies	Specifies whether the Performance Bonus system considers Fuel Economy, Idle Time or both.
Perf. Bonus-Rewarded Distance Base	ADV	4825 km (3000 miles)	250 ~ 17000 km (155 ~ 10560 miles)	Distance (km or miles) over which the Per- formance Bonus targets are evaluated.
Perf. Bonus-Rewarded Increased RSL	AEB	5.0 km/h (3 mph)	0 ~ 20 km/h (0 ~ 12.5 mph)	The in increase in max. vehicle speed when the bonus is awarded. In no case can base RSL + bonus increase exceed 140 km/h (87 mph).
Perf. Bonus-Rewarded Steps	BTR	1	1 ~ 3	The number of steps used when granting the speed bonus (1 = all at once, 3 = give only 1/3 of the bonus at a time).
Perf. Bonus-Target Fuel	ADX	33.6 L/100 km (7.0 mpg)	78 ~ 24 L/100 km (3.0 ~ 9.8 mpg)	The fuel economy target must be main- tained in order to keep the 'bonus' active (mpg = miles per US gallon).
Perf. Bonus-Target Idle	ADY	25%	0 ~ 80%	The idle time target (in percentage of total engine run time) that must be maintained in order to keep the 'bonus' active.
Warmhold Coolant Temp.	AZN	70 °C (158 °F)	70 ~ 80 °C (158 ~ 176 ° F)	Coolant temp. at which Exhaust Pressure Governor (EPG) Warmhold will cutout.

Note: Some default values and adjustment ranges depend upon the value of another parameter. Examples are:

- 1) Parameter 'DV' has a default value of "DP-8 km/h". This means the default value is 8 km/h lower than the value stored in parameter 'DP'.
- 2) Parameter 'DV' has a maximum value of 'DP', meaning that 'DV' can be no larger than the value stored in parameter 'DP'.

Note: Not all parameters may be adjustable in your particular engine or vehicle, because of running changes made to the ECM software. Premium Tech Tool 2 will show only the parameters applicable for your vehicle.

Notes

Low Idle Engine Speed Adjustment

The curb idle speed setting of the engines is adjustable within a certain range, defined by the engine manufacturer. For Volvo engines, this feature is always enabled.

Pin / Connector Information

Not Applicable.

Pre-requisites and Adjustment Procedure

The conditions that must be in place before the idle can be adjusted are the same regardless of the engine. However, the adjustment procedure changes slightly.

Pre-requisites

- Engine coolant temperature must be above 50°C (120°F)
- Accelerator pedal is released, and no accelerator pedal related fault codes are present
- Zero vehicle speed
- Parking brake set

Adjustment Procedure - Volvo Engines

- 1 Set the Cruise Control / PTO stalk switch to the ON position.
- 2 Depress and hold the foot brake throughout the entire procedure.
- 3 Move the Cruise Control / PTO switch to the RESUME position, and hold it for 4 seconds. When the engine speed begins to drop, release the RESUME switch.
- 4 Use the SET+ and SET- switches in the end of the stalk switch to adjust idle speed. The speed cannot be increased above the maximum, or reduced below the minimum values which are preset for the engine (typically 500 ~ 650 RPM for a Volvo engine). "Tap" the SET buttons for smaller RPM increments, "hold" them for rapid changes.
- 5 To store the new setting, simultaneously push and hold both the SET+ and RESUME stalk switches for 4 seconds. Then release the brake pedal.

Note: If an error was made during the procedure, the default idle speed will be restored upon release of the brake pedal. The procedure can be interrupted at any time by releasing the brake pedal.

Notes

Cummins Engine Control Module (ECM)

All parameter and programming information for Cummins engines must be obtained from the appropriate Cummins Engine Company documentation. Typically Cummins' INSITE service tool will be required.

For assistance with circuits available in the ECM, also see the section on prep kit ELCE-EK, which pre-wires certain body builder circuits for the Cummins ECM.

Low Idle Engine Speed Adjustment – Cummins

The curb idle speed setting of the engines is adjustable within a certain range, defined by the engine manufacturer. For Cummins engines, it must be enabled in the ECM. Refer to Cummins literature for details on how to enable this function.

Pin / Connector Information

Not Applicable.

Pre-requisites and Adjustment Procedure

The conditions that must be in place before the idle can be adjusted are the same regardless of the engine. However, the adjustment procedure changes slightly.

Pre-requisites

- Engine coolant temperature must be above 50°C (120°F)
- Accelerator pedal is released, and no accelerator pedal related fault codes are present
- Zero vehicle speed
- Parking brake set

Adjustment Procedure - Cummins Engines

- 1 Set the Cruise Control / PTO stalk switch to the ON position.
- 2 Depress and hold the foot brake throughout the entire procedure.
- 3 Move the Cruise Control / PTO switch to the RESUME position, and hold it for 4 seconds. When the engine speed drops a small amount, release the RESUME switch.
- 4 "Tap" the SET+ and SET- switches in the end of the stalk switch to adjust idle speed. The speed cannot be increased above the maximum, or reduced below the minimum values which are preset for the engine (refer to Cummins documentation for limits).
- 5 To store the new setting, release the brake pedal.

Note: If the above procedure does not perform as shown, it is likely that the low-idle adjustment function is not enabled in the Cummins Engine ECM.

Vehicle Electronic Control Unit (VECU)

There are many programmable features of the VECU; the functions listed here are included because they will be of particular interest to body builders and others needing to modify certain aspects of the VECU. For a complete list of all programmable parameters, see the appropriate Premium Tech Tool 2 parameter and reprogramming information.

Cruise Control

Note: Applies to Volvo Engines Only.

The Cruise Control function will maintain a pre-set vehicle speed (within the engine's capabilities) regardless of terrain or other vehicle load conditions.

The manner in which Cruise Control operates differs depending on the engine:

- **The functionality and programming described below applies to Volvo engines only.**
- **Refer to Cummins engine literature for a description and details of Cruise Control in those engines.**

Pin/Connector Information

This function uses the Cruise Control stalk switches. See the VECU I/O table for pin locations of the Cruise Control On/Off, Resume, and Set + / Set - button inputs.

Pre-requisites / Conditions for Activation

- The function is enabled in the VECU
- Cruise Control stalk switch set to the On position
- Current vehicle speed is between Cruise Control MAX and MIN vehicle speed parameters
- Clutch and Brake pedals are released
- No Vehicle Speed Sensor (VSS) related faults
- No J1939 control data link related faults in the VECU or ECM

Press either the SET+ or SET- switch to select the current vehicle speed as the "set" speed. A Cruise Control ("CC") icon will appear in the instrument cluster while the Cruise Control governor is engaged. Once active, the SET buttons may be used to adjust the CC set speed within programmed limits. Speed changes may be made either as a "ramp" (by holding the SET+ or SET- button), or as a "step" change (by tapping the buttons).

The Cruise Control Maximum Set Speed is the maximum vehicle speed allowed while in CC mode; note that it may be different (higher or lower) than the overall maximum vehicle speed limit set in the Engine ECM, but the overall speed limit will be enforced if it is lower than the CC Maximum Set Speed.

If disengaged for any reason (any of the pre-requisites above are no longer met), the Cruise Control RESUME button will re-engage Cruise Control and restore the last "set" speed.

If load or terrain conditions are such that the vehicle speed is reduced below the Minimum Governed Speed while the Cruise Control is engaged, the Cruise Control governor will drop out.

Parameter codes

Parameter Name	Code	Default Value	Range	Description
F_ENABLE_CRUISE_CONTROL	AG	1	0/1	Enables the CC Function.
CC Maximum Set Speed	AI	130 km/h (81 m/h)	30 ~ 140 km/h (19 ~ 87 m/h) must be > BK	Maximum CC Set speed allowed.
CC Minimum Set Speed	BK	30 km/h (19 m/h)	30 ~ 140 km/h (19 ~ 87 m/h) must be < AI	Minimum CC Set speed allowed.
CC Minimum Governed Speed	BL	15 km/h (9 mph)	15 ~ 30 km/h (9 ~ 19 m/h)	Vehicle speed below which the Cruise governor will no longer attempt to maintain preset speed.
Cruise Trim Factor	GP	2 km/h per second (1 mph/ per second)	0 ~ 10 km/h (0 ~ 6 m/h) per second	Specifies the speed change ramp (in km/h per second) that will be requested when the SET+ button is held.
Cruise Trim Factor Minus	RR	2 km/h per second (1 mph/ per second)	0 ~ 10 km/h (0 ~ 6 m/h) per second	Specifies the speed change ramp (in km/h per second) that will be requested when the SET- button is held.
Cruise Step Factor	RS	2 km/h (1 mph)	0 ~ 10 km/h (0 ~ 6 m/h)	Specifies the step speed change (in km/h) that will be requested when 'tapping' either the SET+ or SET- buttons.

Other Information/Notes

None.

Notes

Manual Fan Input

This active high input can be used as a manual override to turn on the engine cooling fan, typically for applications demanding extra cooling.

Note: Turning this switch off does not disable the fan.

Pin/Connector Information

Pin Name	I/O, Type	VECU Pin No.	ELCE-xx Connector Pin	Comment
Manual Fan (Override) Input	Input, Active High	A19	N/A	Use N.O. switch to +V

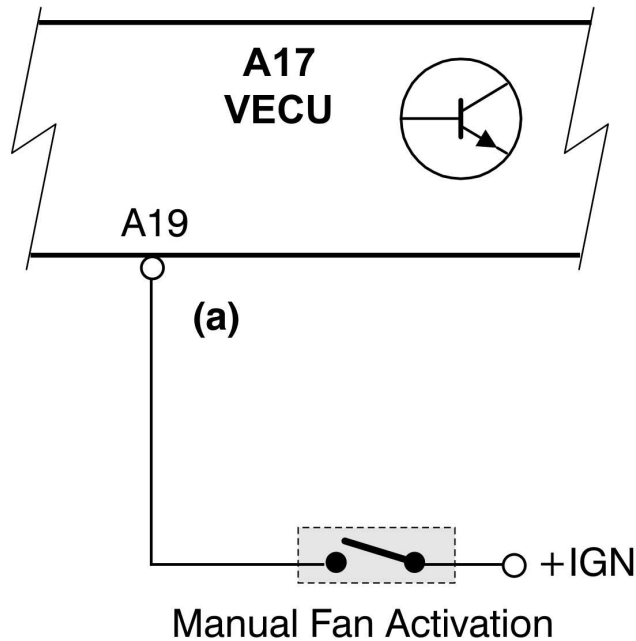

W3007636

Pre-requisites / Conditions for Activation

- Manual Fan Input pin must be active.
- If Cummins engine, "fan accessory switch" must be ON in multiplexing setup, but OFF in general 'Fan Features' setup.

Related VECU ECU Parameters/Setup for Premium Tech Tool 2

None.

Other Information/Notes:

When used for a Volvo engine, the manual fan input must be connected as shown above.

When used with a Cummins engine, there are two choices:

- Wire to the VECU as outlined above.

Note: The multiplexing setup in the ECM must be such that the “fan accessory switch” is enabled. The general “fan features” setup should be disabled.

- Wire to the ECM.

Note: In this case the manual fan must be enabled in the general “fan features” setup, and the wiring to the ECM must use a Normally Closed (N.C.) switch to ground instead of the N.O. switch to +V shown above for the VECU connector.

Note: This input is not routed to the Body Builder connector(s) on VHD (from build date 11.2002) vehicles.

Notes

“Stalk” PTO Operation

This mode of operation, sometimes called "high idle" or "stalk PTO" (Mack calls it "Electronic Hand Throttle" (EHT)), is available in all vehicles regardless of engine, transmission, or level of Body Builder prep.

With a Volvo engine, all Stalk PTO functions are programmed in the VECU. With a Cummins engine, the VECU plays no part aside from sending information on the state of the switches to the Cummins ECM.

"Stalk PTO" is a mode which uses the Cruise Control stalk switches to control the engine speed. It can be used for PTO engine speed control, to maintain engine speed at an elevated idle speed for faster warm-up, or can be used to prevent idle shutdown from occurring.

Pin/Connector Information

This function uses the Cruise Control stalk switches. See the VECU I/O table for pin locations of the Cruise Control On/Off, Resume, and Set+ / Set- button inputs.

On VHD vehicles only, the Set+ and Set- buttons are also brought out to the body builder connector for remote speed adjustment; refer to the section on the "ELCE-PK Prep Kit" for details.

Pre-requisites/Conditions for Activation

This function is operational when all of the following are true:

- Cruise control stalk switch is "ON"
- Vehicle speed is below some limit (programmable)
- No active Vehicle Speed Sensor (VSS) faults logged in any of the ECUs
- Park brake must be applied (N/A with Cummins engine, programmable w/ Volvo engine)
- Brake pedal not depressed (programmable)
- Clutch pedal (if equipped) not depressed (programmable with Cummins engine)
- None of the "remote PTO" functions (described below) are active (Volvo Engine Only)

The manner in which this mode operates will depend upon the installed engine:

With Volvo Engine (programmable functions handled in VECU):

Pressing the "CC_Resume" button will take the engine to the preset speed programmed in VECU parameter HIGH_IDLE_DEFAULT_RES_ESPD (parameter code ANE). Engine speed may be adjusted up or down from the default speed by either 'tapping' (for step-changes) or 'holding' (for ramp-changes) the "CC_Set(+)" or "CC_Set(-)" buttons. The RPM change for step changes is programmable in the VECU; the ramp change rate is fixed at 50 RPM per second. When adjusting the speed using this method, Min. and Max. engine speed limits programmed into the VECU will be enforced. This mode may also be entered by using the Accelerator Pedal to obtain the desired engine speed, then pressing "CC_Set(+)" or "CC_Set(-)", which will then maintain the current engine speed.

The accelerator pedal can be used to override the PTO set speed at any time while in Stalk PTO. There is no way (without the Engine Speed Limit Input of the BBM) to prevent AccPedal override while in any PTO mode.

With Cummins Engine (programmable functions handled in ECM):

Refer to the "PTO Functions - General Information and Overview" section above for Stalk PTO operation with the Cummins engine. All Stalk PTO parameters in this case are programmed in the Cummins ECM, not the VECU.

Related VECU Parameters/Setup for Premium Tech Tool 2 (Volvo Engines Only)

Parameter Name	Code	Default Value	Range	Description
HIGH_IDLE_DEFAULT_RES_ESPD	ANE	750	Must be within a window defined by parameters ANF ~ AND	Default RESUME Engine Speed for "Stalk PTO" (high idle).
HIGH_IDLE_MIN_ESPD	ANF	500 RPM	500-2500 RPM	Minimum allowed PTO engine speed; "ANF" must be < "AND"
HIGH_IDLE_MAX_ESPD	AND	2500 RPM	500-2500 RPM	Maximum allowed PTO engine speed; "AND" must be > "ANF". Note that this parameter does not limit the engine speed when using the accelerator pedal as an override.
PTO_HIGH_IDLE_BRAKE_COND	XP	1	0/1	Specifies whether the service brake pedal must be released in order to maintain PTO engine speed control ("high idle"). 0 = No / 1 = Yes
PTO_HIGH_IDLE_PARKINGBRAKE_CONDITION	AZG	0	0/1	Specifies whether the Park Brake must be set in order to maintain PTO engine speed control ("high idle"). 0 = No / 1 = Yes
PTO_STEP_FACTOR	RT	50 RPM	1-250 RPM	Each short press of the CC Set(+) or Set(-) buttons will trim the set speed by this amount.
PTO_MAX_VSPD	DA	12 km/h (7.5 mph)	0-30 km/h (0-19 mph)	PTO Engine Speed Control mode will drop out if Vehicle Speed exceeds this value.

Other Information/Notes

The PTO_STEP_FACTOR parameter only affects the "step" adjust function when the CC Set(+) or Set(-) buttons are "tapped". If the buttons are "held", a fixed ramp rate of 50 RPM per second will be used.

The "remote" Stalk PTO Engine Speed Increase / Decrease circuits provided by the ELCE-PK prep. package act in parallel with the stalk Set(+) and Set(-) pushbuttons. All operations outlined above apply to the "remote" speed adjustment, with the added requirement that the parking brake be set before the "remote" circuits become active.

Driver Tamper: The brake and accelerator pedals are driver inputs which can be left applied to indefinitely prevent idle shutdown in previous versions. Later versions have some time and tolerance for change and will otherwise allow idle shutdown even when applied. Parameters that affect this are PPL, MWP, MWQ and MWR but are only visible in central systems.

Notes

“Remote” (Wired) PTO1 Operation with VECU (Volvo Engines Only)

When only a VECU is present (no BBM ECU), the Volvo Engine is limited to one (1) remote or "wired" PTO function. This is referred to as "PTO1". The PTO1 function actually consists of two parts:

- An Input / Enable pin, used to (a), enable the PTO1 Output, and (b), enable the engine speed control mode (if desired).
- A PTO1 Output pin, used to physically power the PTO device under the proper conditions.

Both functions are related, but somewhat independently set-up.

When a BBM ECU is added, three more PTO functions are added - refer to the appropriate section for more information on the BBM ECU and the ELCE-CK package.

This section deals only with the PTO1 function contained within the VECU. Note that the PTO1 function in the VECU is not usable with Cummins engines.

The PTO1 function is contained in all vehicles with a Volvo engine - VN and VHD. In addition, for VHD only, access to the PTO1 Input and Output circuits is also available in the body builder connector.

Pin/Connector Information

Pin Name	I/O, Type	VECU Pin No.	ELCE-PK Connection Pin	Comment
PTO1 Input / Enable Input	Input, Active High	A29	Conn 1 Pin N	
PTO1 Output	From VECU: Output, Active Lo From ELCE-PK Connector: Active High	B16	Conn 1 Pin M	Note that the PTO1 Output pin from the VECU (PB-16) is connected to Relay R07 which inverts the PTO1 Output signal to an Active High state. At the ELCE-PK connector, the output is Active High, 5A Max.

Pre-requisites/Conditions for Activation

- Parameter PTO_BASIC_MODE_ENABLE must be set.
- The PTO1 Input / Enable Input pin must be activated.
- If PTO Output activation is desired, parameter PTO_SET_OUTPUT must be set.
- CC On/Off switch must be ON.
- If desired, the activation of the PTO1 Input / Enable pin will also command engine speed control (will act as if the "stalk PTO" mode had been engaged using the CC Resume switch).
- The service brake pedal is not depressed (only affects Engine Speed Control, and is programmable).
- The park brake must be applied (programmable for both Engine Speed Control & Output control).
- Engine speed must be non-zero, and no engine speed related faults.
- Vehicle speed must be below a programmed limit, and no vehicle speed related faults active.
- The PTO1 Input / Enable Input pin must have been turned off at least once during the current ignition key cycle, in order to prevent a stuck-on switch from engaging PTO unintentionally.

Related VECU Parameters/Setup for Premium Tech Tool 2 (Volvo Engines Only)

Parameter Name	Code	Default Value	Range	Description
PTO_BASIC_MODE_ENABLE	QP	1	0/1	Enables / Disables entire PTO1 function in the VECU. Currently does not affect the High Idle Function.
PTO_HIGH_IDLE_BRAKE_COND	XP	1	0/1	Specifies whether the service brake pedal must be released in order to maintain PTO engine speed control ("high idle"). 0 = No / 1 = Yes
PTO_HIGH_IDLE_PARKINGBRAKE_CONDITION	AZG	0	0/1	Specifies whether the Park Brake must be set in order to maintain PTO engine speed control 0 = No / 1 = Yes
F_ENABLE_HIGH_IDLE_WITH_PTO_ENABLE_SW	AZH	0	0/1	Specifies whether PTO Engine Speed control mode (aka "stalk PTO" or "high idle" mode) will be initiated when the PTO1 Input / Enable pin is activated. 0 = No / 1 = Yes
PTO_OUTPUT_PARKINGBRAKE_CONDITION	XM	1	0/1	Specifies whether Park Brake must be set in order for PTO1 Output to become active. 0 = No / 1 = Yes
PTO_OUTPUT_TYPE	XN	3 (ENG)	1-4	Specifies where the PTO device is located (engine or trans.) Only needed when a Volvo-brand transmission is installed; any other transmission can accept any value (1 ~ 4) in this parameter with the same results.
PTO_SET_OUTPUT	XO	1	0/1	Set to 1 if desire the PTO1 Output pin to be driven while the PTO1 Input/Enable pin is active. Set to 0 if the PTO Output pin will not be used. Otherwise, on some versions the PTO Input will not function correctly.
HIGH_IDLE_DEFAULT_RES_ESPD	ANE	750	Must be within a window defined by parameters ANF ~ AND	Default RESUME Engine Speed for "Stalk PTO" (high idle).
HIGH_IDLE_MIN_ESPD	ANF	500 RPM	500-2500 RPM	Minimum allowed engine speed; "ANF" must be < "AND"
HIGH_IDLE_MAX_ESPD	AND	2500 RPM	500-2500 RPM	Maximum allowed engine speed; "AND" must be > "ANF". Note that this parameter does not limit the engine speed when using the accelerator pedal as an override.
PTO_STEP_FACTOR	RT	50 RPM	1-250 RPM	Each short press of the CC Set (+) or Set (-) buttons will trim the set speed by this amount.
PTO_MAX_VSPD	DA	12 km/h (7.5 mph)	0-30 km/h (0-19 mph)	Engine Speed Control mode will drop out if Vehicle Speed exceeds this value.

Other Information/Notes

If the vehicle was ordered with one of the available side-engine PTOs factory installed, everything will be pre-wired (from the VECU to the PTO pump, including the dash switch). The VECU will be programmed for default PTO operation as described in the parameter setting table above. For further information refer to Fig. 8 on page 80 .

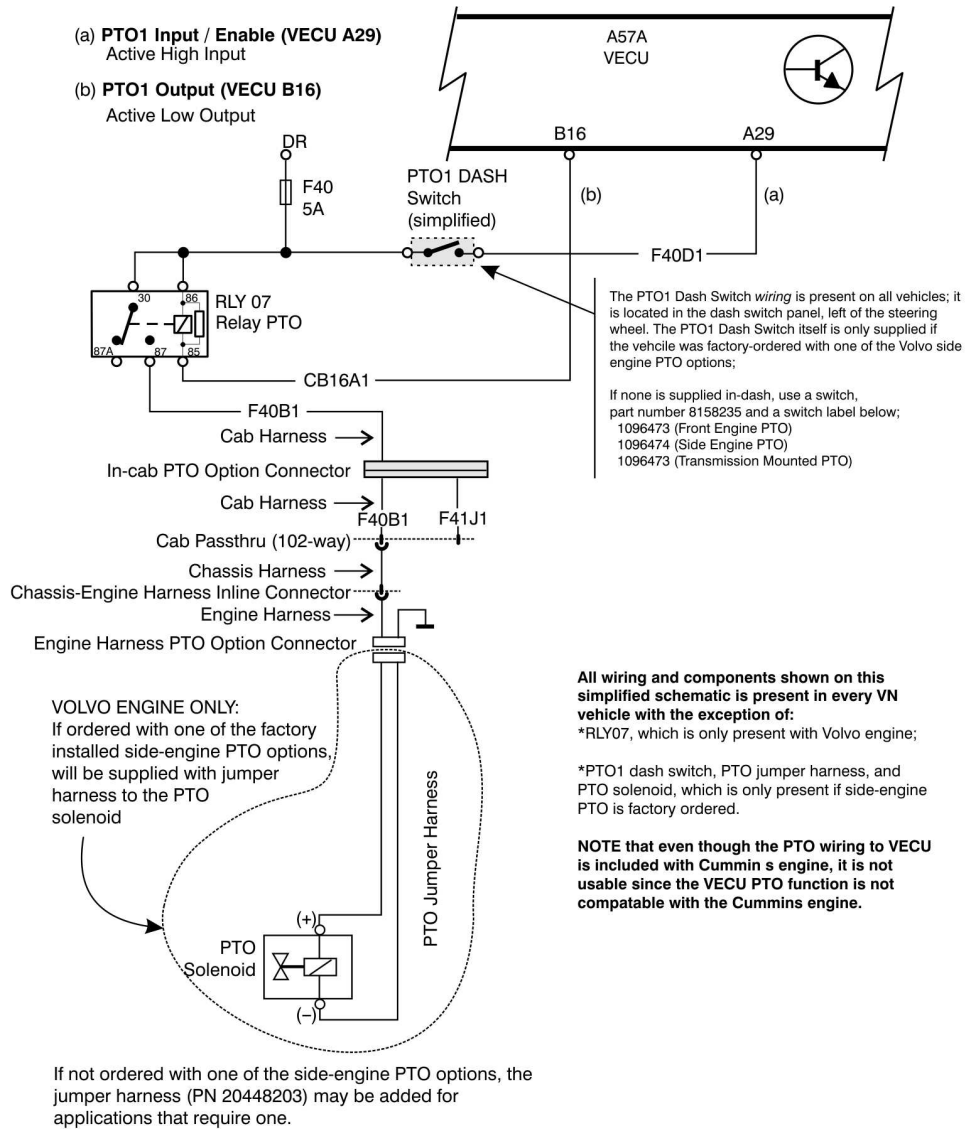

W3084358

Fig. 8 PTO1 Input & Output using the VECU (VN vehicles)

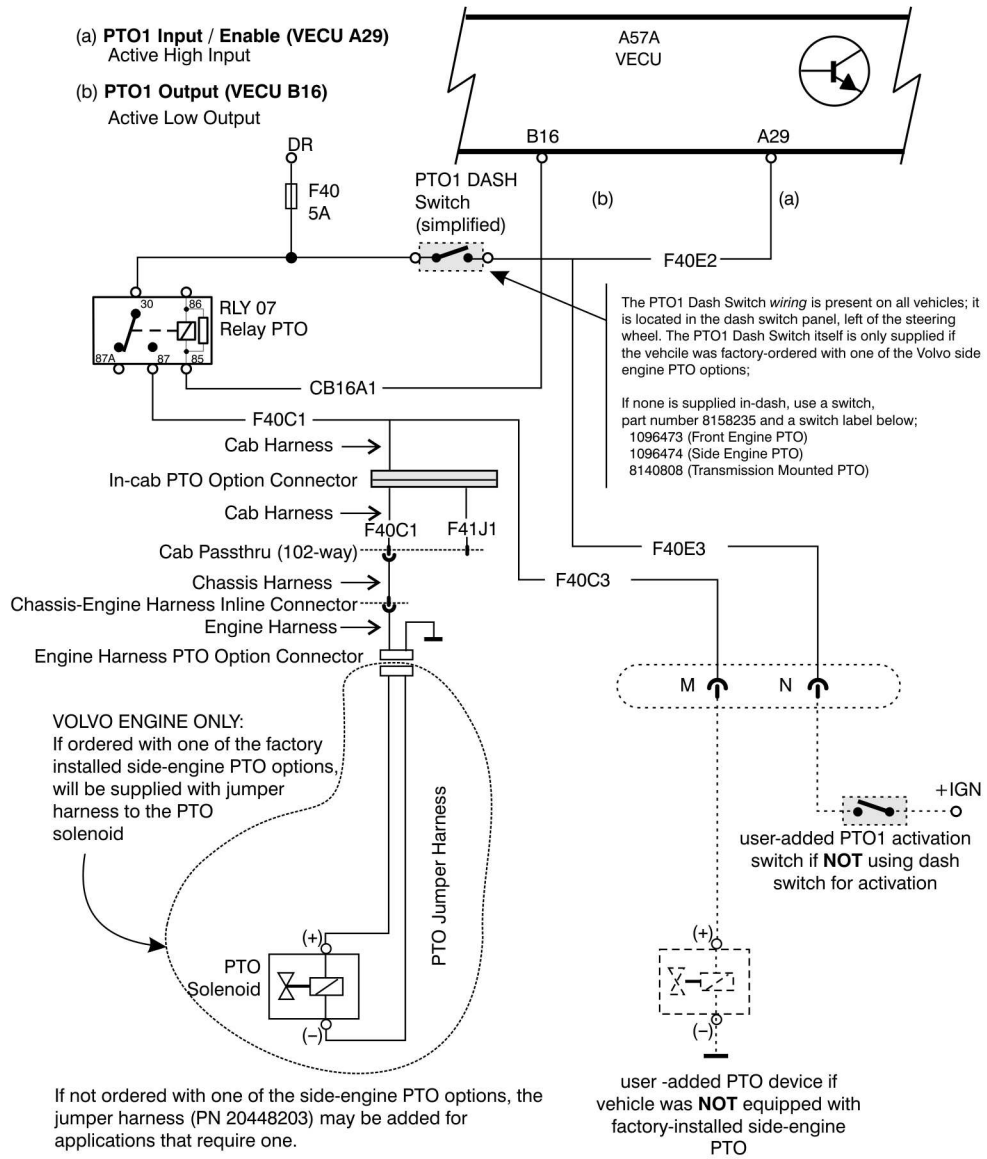

W3084359

Fig. 9 PTO1 Input & Output using the VECU (VHD vehicles except with Twin Flow PTO)

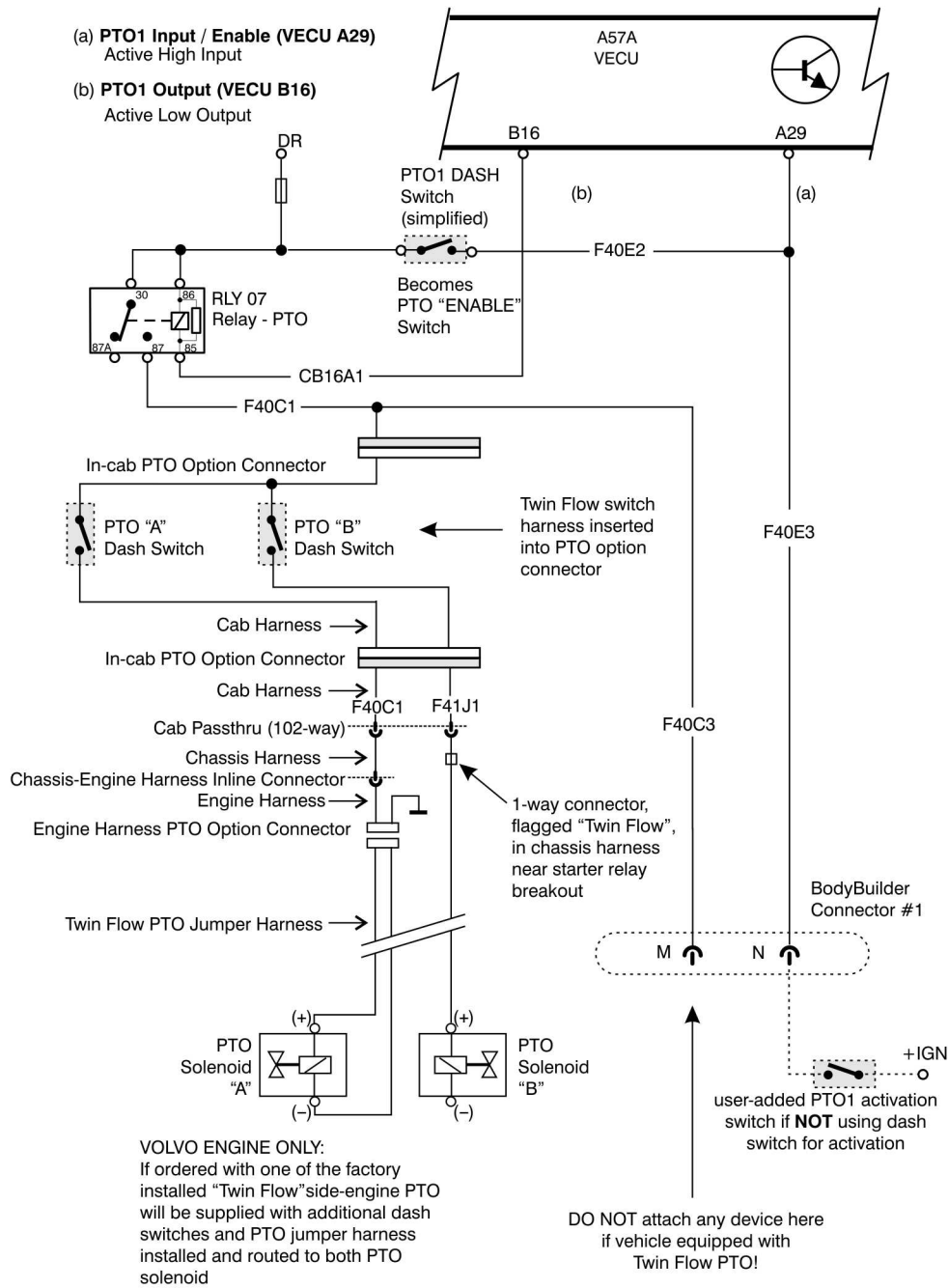

W3084360

Fig. 10 PTO1 Input & Output using the VECU (VHD vehicles with Volvo Engine and Twin Flow PTO)

If NOT ordered with a factory-installed side-engine PTO, the wiring is still in place, but tied up in the firewall area near the starter relay. Also, no dash switch will be provided - but the wiring is in place behind the switch panel to the left of the steering column.

The PTO1 Output pin of the VECU (pin PB-16) is a low-side output driver capable of sinking 1A maximum. In order to increase the current-handling capacity, it is connected to a Relay (R07) as part of the base wiring harness. This relay inverts the output function (making it Active HIGH), and allows a maximum current to 5A. It is this Active HIGH / 5A circuit that is connected to the ELCE-PK body builder Connector #1, cavity #M (circuit number 639-A).

The PTO_STEP_FACTOR parameter listed only affects the "step" function when the CC Set(+) or Set(-) buttons are "tapped". If the buttons are "held", a fixed ramp rate of 50 RPM per second will be used.

The "remote" Stalk PTO Engine Speed Increase / Decrease circuits provided by the ELCE-PK prep. package act in parallel with the stalk Set (+) and Set (-) pushbuttons. All operations outlined above apply to the "remote" speed adjustment, with the added requirement that the parking brake be set before the "remote" circuits become active.

Note that one of the conditions for operation is that:

"The PTO1 Input / Enable Input pin must have been turned off at least once during the current ignition key cycle, in order to prevent a stuck-on switch from engaging PTO unintentionally". Because of this, it is important to connect this switched input to a power supply source that does not drop out during cranking. If using the factory installed PTO1 dash switch wiring (supplied on all vehicles), this is done already. If using some other method of connection, it is suggested to use a "a non-ignition-switched battery voltage source for this input.

Notes

Description of VECU Signals

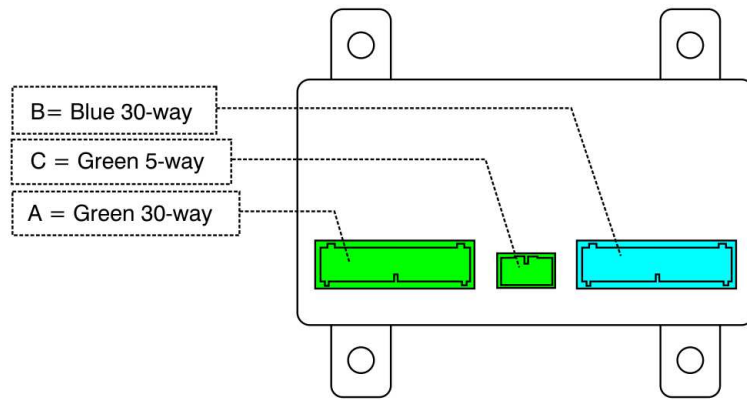

W3088359

VECU Connector A (Green)

Pin	Pin Name/Description	I/O	Type	Comment
A1	CC Set (-) SW	Input	Active High	
A2	CC Set (+) SW	Input	Active High	
A3	CC On/Off SW	Input	Active High	
A4	SPARE	SPARE	SPARE	
A5	Brake Pedal Microswitch	Input	NC Switch to +V	NO SWITCH INSTALLED. WIRED TO +V
A6	Keyswitch: Crank	Input	Active High	
A7	Keyswitch: Preheat	Input	Active High	Used with Volvo engine only
A8	Clutch Pedal Microswitch	Input	NC Switch to +V	Switch Open = pedal depressed
A9	Spare	Input	Active High	
A10	Spare	Input	Active High	
A11	Neutral Start Relay, I-Shift	—	—	—
A12	ECU Ground	ECU Main Power Ground		
A13	ECU Main Power	Input	ECU Main Power	
A14	Keyswitch: Ignition	Input	Active High	
A15	CAN2-High (Tachograph)	Bidirectional Databus		For connection to the Digital Tachograph only
A16	CAN2-Low (Tachograph)	Bidirectional Databus		For connection to the Digital Tachograph only

Pin	Pin Name/Description	I/O	Type	Comment
A17	Not Used	Input	Active High	Do not connect; special use only
A18	Idle Validation SW #2	Input	Active High	Not used
A19	Empty	—	—	—
A20	Engine Brake, Dash SW 1	Input	Active High	
A21	Engine Brake, Dash SW 2	Input	Active High	
A22	Not Used	Input	Active High	Do not connect; special use only
A23	Idle Validation SW #1	Input	Active High	
A24	A/C Hi-Press Fan SW Input	Input	NC Switch to Ground	Open Switch = High A/C Pressure = Fan Requested
A25	Not Used	—	—	—
A26	Spare	Input	Active Low	
A27	ECO Roll Switch	Input	Active Low	
A28	Not Used	Input	Active Low	Do not connect; special use only
A29	PTO1 Input/Enable	Input	Active High	Used with Volvo engine only
A30	CC Resume SW	Input	Active High	

Notes

VECU Connector B (Blue)

Pin	Pin Name/Description	I/O	Type	Comment
B1	Regeneration Control	Output	Active Low	Air Dryer ECADS
B2	Not Used	Output	Active Low	
B3	IVS-Out-Low	Output	Active Low	Used with Cummins engine only
B4	Compressor Control	Output	Active Low	Air Compressor ECADS
B5	Output Supply # 4 (-Vbatt)	Output	Switch Power	
B6	Vehicle Speed Sensor (+)	Input	Analog	
B7	Not Used	Input	Active High	Do not connect; special use only
B8	Accelerator Pedal	Input	Analog Sensor	
B9	Air Tank Pressure	Input	Analog Sensor	ECADS
B10	Output Supply # 1 (~5V)	Output	Sensor Power	
B11	Parking Brake	Input	Active Low	Ground connected N.C. air switch (No air = switch closed = PB applied)
B12	Spare	Input	Active Low	
B13	Spare	Input	Active Low	
B14	Not Used	Input	Analog Sensor	Do not connect; special use only
B15	EMS Power Relay Control	Output	Active Low	
B16	PTO 1 Output	Output	Active Low	Used with Volvo engine only
B17	Buffered IVS1	Output	Active High	Used with Volvo engine only
B18	Not Used	Output	Active Low	Do not connect; special use only
B19	Output Supply # 3 (~Vbatt)	Output	Switch Power	
B20	Vehicle Speed Sensor	Input	Analog	
B21	Not Used	Input	Active High	Do not connect; special use only
B22	Analog Ground	ECU Sensor Ground		
B23	Analog Ground	ECU Sensor Ground		
B24	Retarder Stalk Switch	Input	Analog Sensor	Used with Cummins engine with 6 position Engine Brake only
B25	Speed Sensor, I-Shift	Output	Powered VSS	
B26	Output Supply # 2 (~5V)	Output	Sensor Power	
B27	Brake Pressure Switch	Input	Analog/ Active Low	Analog Input used to read ground-connected normally. Open Brake Pressure Switch (Not Sensor)
B28	Idle Shutdown Relay	Output	Active High	Volvo engine only*
B29	Not Used	Input	Active Low	Do not connect; special use only
B30	Spare	Input	Active High	

Note: *B28 output is only available in VECUs built after September 2003.

VECU Connector C (Green)

Pin	Pin Name/Description	I/O	Type	Comment
C1	J1587/1708 Information Data Link (B) (SAE J1708 (A))		Bidirectional Databus	J1587/1708 Information Data Link (Slow Speed) Databus
C2	J1587/1708 (A) (SAE J1708 (B))			
C3	No connect	—	—	—
C4	J1939 Control Data Link/A (CAN_H)		Bidirectional Databus	J1939 Control Data Link (High Speed) Databus
C5	J1939 Control Data Link/B (CAN_L)			

Notes

BBM ECU

Engine Shutdown Inputs

Note: The BBM only has the ability to shutdown the engine with the two inputs shown below. The engine must be restarted manually.

Two inputs (one 'always active', one 'programmable') are provided to allow remote engine shutdown. The first input ("Engine Shutdown, N.O.") is always 'enabled', and is to be left unconnected if its use is not required. The second input ("Engine Shutdown, N.C.") must be enabled in software if its use is desired. In this case, when a normally-closed (N.C.) switch to ground is opened, the engine will shutdown.

Pin Name	I/O Type	BBM ECU Pin No.	ELCE-CK Connector Pin	Comment
Engine Shutdown Input (N.O.)	Input, N.O. Switch to +V	A6	Connector 4, Pin A	Use Normally Open switch to +V; close switch for shutdown
Engine Shutdown Input (N.C.)	Input, N.C. Switch to 0V	A27	Connector 4, Pin B	Use Normally Closed switch to ground; open switch for shutdown. *Must be enabled

- (a) Engine Shutdown Input / NO (pin A6)
- (b) Engine Shutdown Input / NC (pin A27)
- (c) BBM-supplied +V Switch Supply

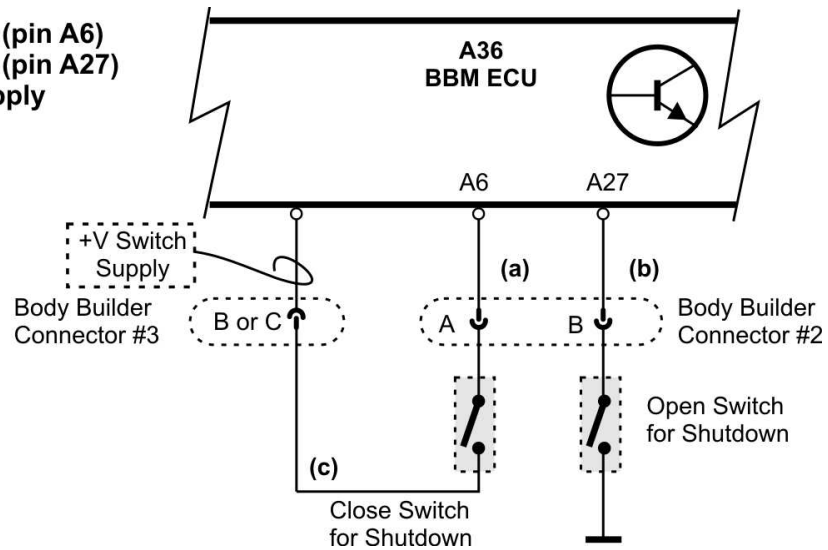

W3127853

Note: All grounds from ELCE-PK powered circuits connect to terminal A, connector 1.

Pre-requisites/Conditions for Activation

- Vehicle speed must be zero (and no Vehicle speed related fault codes in VECU)
- The parking brake is applied
- For "Engine Shutdown, N.C.", the input must be enabled (see parameters, below)
- At least one of the two Engine Shutdown Input pins is active

Related BBM ECU Parameters/Setup for Premium Tech Tool 2

Parameter Name	Code	Default Value	Range	Description
F_ENABLE_SHUT-DOWN_INPUT	IL	0 (OFF)	0/1	Must be enabled to use N.C. switch input (Pin A27)
F_ENGINE_REMSTOP_PARK_BRAKE_ENABLE	IHM	1	0/1	
VEHICLE_SPEED_THRESHOLD_SHUTOFF	IHN	0 kmph (0 mph)	0 - 255 kmph (0 - 158 mph)	

Note: When using the N.C. Shutdown Input (BBM ECU Pin A27), ensure the wiring is in place before enabling the parameter. The engine will not start while any of the Shutdown Inputs are active.

Note: These Shutdown Inputs shall not be used for emergency shutdown purposes, as their operation relies on the J1939 databus for operation.

Notes

Resume to Pre-set Speed

Once a pre-set PTO speed input is enabled, per the PTO engine speed control setting (see “PTO Engine Speed Control Inputs”, page 113) and the user increase or decrease the engine speed using the PTO engine speed increment/decrement inputs (see “PTO Engine Speed Increment/Decrement Inputs”, page 119).

This input will force the engine speed to return to the original selected PTO pre-set speed.

This input has priority over any active PTO modes, as well as any driver-demand inputs such as the accelerator pedal.

Pin/Connector Information

Pin Name	I/O, Type	BBM ECU Pin No.	ELCE-CK Connector Pin
PTO pre-set speed resume	Input, Active High	A7	Connector 4 Pin C

- (a) PTO pre-set speed resume (pin A7)
 (b) BBM-supplied +V Switch Supply

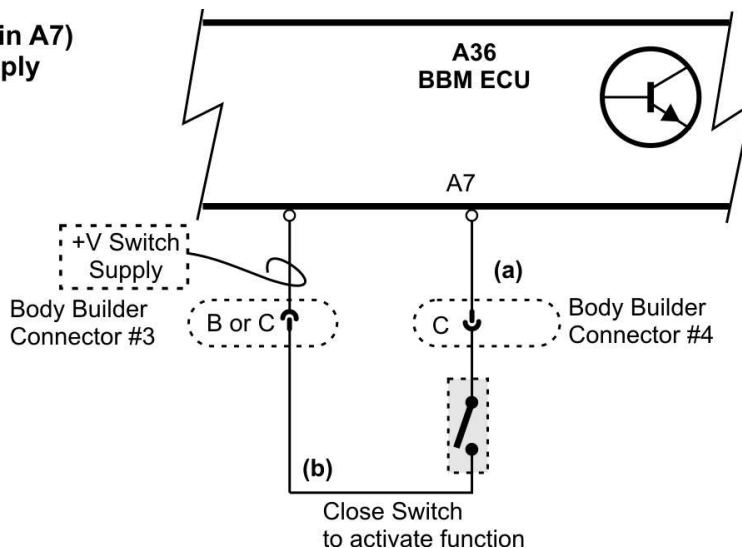

W3127854

Pre-requisites/Conditions for Activation

- Function must be enabled in the BBM
- PTO pre-set speed resume input pin must be active
- PTO pre-set engine speed input must be active (see “PTO Engine Speed Control Inputs”, page 113)

Related BBM ECU Parameters/Setup for Premium Tech Tool 2

Parameter Name	Code	Default Value	Range	Description
ENGINE_SPEED_MODE_RESUME_SWITCH_TOGGLE	IFS	1 (ON)	0/1	

Engine Speed Limit Input

Allows a switchable engine speed limit to be imposed. If several engine speed limits are in effect at the same time (e.g., this hardware input, PTO Engine Speed Limit, etc.), the lowest speed limit will have priority.

Pin/Connector Information

Pin Name	I/O, Type	BBM ECU Pin No.	ELCE-CK Connector Pin
Engine Speed Limit Input	Input, Active High	A17	Connector 4 Pin D

(a) Engine Speed Limit Input (pin A17)
(Active High Input)

(b) BBM-supplied +V Switch Supply

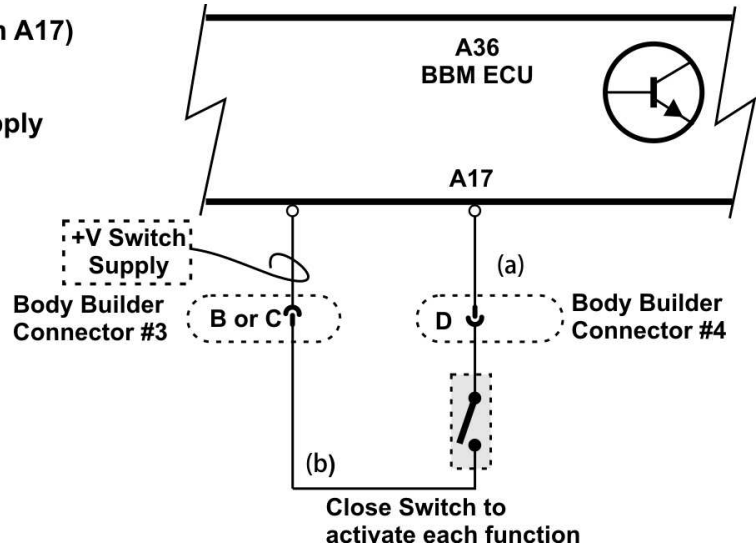

W3127789

Pre-requisites/Conditions for Activation

- Function must be enabled in the BBM
- Engine Speed Limit Input pin must be active

Related BBM ECU Parameters/Setup for Premium Tech Tool 2

Parameter Name	Code	Default Value	Range	Description
F_ENABLE_ESPD_LIMIT	GU	0 (OFF)	0/1	
ENGINE_SPD_LIMIT_MAX_ESPD	GQ	2500 RPM	500-2500 RPM	Engine speed limit while input is active

Engine Torque Limit Input

Allows a switchable engine torque limit to be imposed. If several engine torque limits are in effect at the same time, the lowest torque limit will have priority.

Pin/Connector Information

Pin Name	I/O, Type	BBM ECU Pin No.	ELCE-CK Connector Pin
Engine Torque Limit Input	Input, Active Low	A25	Connector 4 Pin E

(a) Engine Torque Limit Input (pin A25)
(Active Low Input)

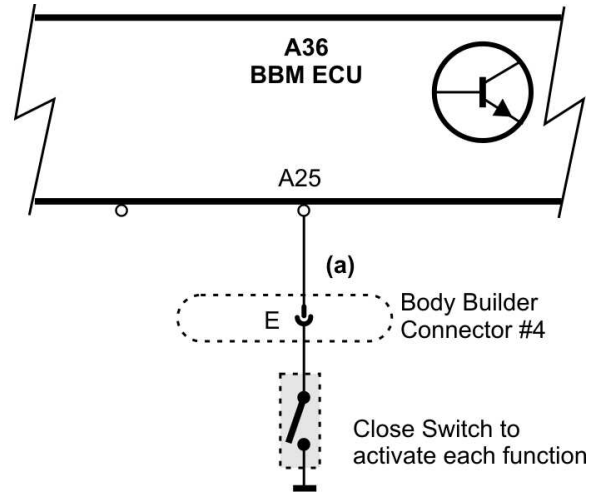

W3127855

Note: All grounds from ELCE-PK powered circuits connect to terminal A, connector 1.

Pre-requisites/Conditions for Activation

- Function must be enabled in the BBM
- Engine Torque Limit Input pin must be active

Related BBM ECU Parameters/Setup for Premium Tech Tool 2

Parameter Name	Code	Default Value	Range	Description
F_ENABLE_TORQUE_LIMIT_1	GW	0 (OFF)	0/1	
ENGINE_TORQUE_LIMIT	GR	100 %	0 - 100 %	Engine torque limit while input is active

Note: Selecting a torque limit less than needed for maintaining the engine at idle will not stall the engine (since the idle governor will have priority), but it will result in no engine speed increase when using the accelerator pedal.

Note: The torque limitation can be used in PTO mode as well.

Road Speed Limit Input

Allows a switchable road speed limit to be imposed. This limit is separate from all other vehicle speed limits (such as CC max set speed, max Road Speed Governor, 2nd/Remote Throttle Road Speed Limit, etc.). When multiple road/vehicle speed limits are imposed, the lowest will have priority.

Pin/Connector Information

Pin Name	I/O, Type	BBM ECU Pin No.	ELCE-CK Connector Pin
Road Speed Limit Input	Input, Active Low	A26	Connector 4 Pin F

(a) Road Speed Limit Input (pin A26)
(Active Low Input)

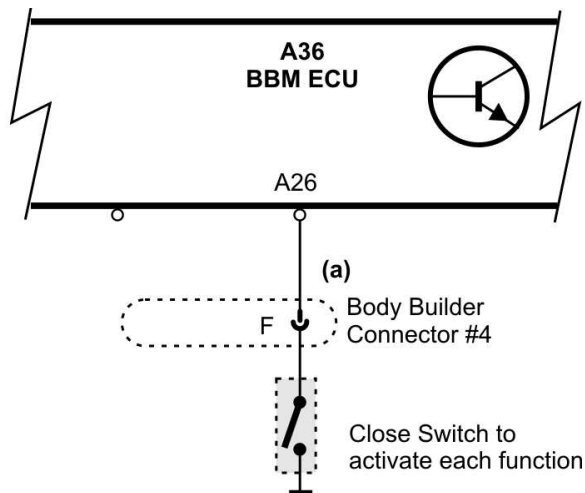

W3127856

Note: All grounds from ELCE-PK powered circuits connect to terminal A, connector 1.

Pre-requisites/Conditions for Activation

- Function must be enabled in the BBM
- Road Speed Limit Input pin must be active

Notes

Related BBM ECU Parameters/Setup for Premium Tech Tool 2

Parameter Name	Code	Default Value	Range	Description
F_ENABLE_RSL	GV	0 (OFF)	0/1	Road speed limit optional vehicle speed set. Optional Road Speed Limit Value. When using a value lower than 30 km/h (19 mph), it must be secured that the engine works with at least 1000 rpm at chosen vehicle speed limit.
ROAD_SPEED_LIMIT	IG	30 km/h (18 mph)	5 - 140 km/h (3 - 87 mph)	Road Speed Limit in effect while this input is active.
F_ENABLE_REVERSE_INHIBIT_RSL NOTE: Can be set to 1 only if GV is enabled.	AIA	0 (OFF)	0/1	Enable Reverse Inhibit Road Speed Limiter. With the parameter activated reverse gear cannot be engaged on the automatic gearbox.
ACC_SECOND_PEDAL_ENABLE	EE	0 (OFF)	0 – Accelerator pedal functionality disabled 1 – Pedal enabled 2 – Switch used for disable of primary pedal	Second accelerator pedal. This parameter is used to activate extra throttle control and also there is an option to disable the primary accelerator pedal.
ACC_SECOND_PEDAL_RSL	GO	20 km/h (12 mph)	5 - 140 km/h (3 - 87 mph)	Dual Drive Road Speed Limit Value together with Second Driver Interface. When using a lower value than 30 km/h (19 mph), it must be secured that the engine works with at least 1000 rpm at chosen vehicle speed limit.
RSL_ACC_PEDALVALUE_POSITION	FNP	20%	4 - 100%	RSL ACC pedal value position. If parameter FNO is "YES", Road Speed Limit will not exit until accelerator pedal position is less or equal then this parameter value.
F_TEMP_ROAD_SPEED_LIM_ENABLE	IFW	0	0 – Temporary RSL function is not active 1 – Temporary RSL function is active	Temporary RSL enable. Enable and disable the Temporary RSL function. Temporary RSL (Road Speed Limit) is used to help the driver not to exceed a temporary speed

Parameter Name	Code	Default Value	Range	Description
				limit that can be prevailing inside a construction area.
F_RSL3_SPEED_LIM_ENABLE	LIN	0	0 – RSL3 function is not active 1 – RSL3 function is active	Enable RSL3 for BBM. Enable the RSL3 function for BBM.
RSL3_SPEED_LIMIT	CEC	20 km/h (12 mph)	5 - 250 km/h (3 - 155 mph)	Limit value for RSL3. Road speed limit value for RSL3 Note: This value must be below the values of the legal speed limiter.
F_ENABLE_LOWEST_START_GEAR_REQ	IZV	0 (OFF)	0/1	Enable Lowest gear as starting gear. Set lowest gear to starting gear as long as the RSL3 input is active, even if the RSL3 speed limit is set to a high value.
HANDTHROTTLE_ACTIVE	ZX	0 (OFF)	0/1	Enable Hand Throttle. This parameter activates the hand throttle potentiometer.
PTO_OUT2_MAX_ROAD_SPEED	EAR	161 km/h (100 mph)	5 - 255 km/h (3 - 158 mph)	Road speed limit value for PTO2.
PTO_OUT3_MAX_ROAD_SPEED	EAS	161 km/h (100 mph)	5 - 255 km/h (3 - 158 mph)	Road speed limit value for PTO3.
PTO_OUT3_MAX_ROAD_SPEED	EAT	161 km/h (100 mph)	5 - 255 km/h (3 - 158 mph)	Road speed limit value for PTO4.
PTO_OUTX_LEGAL_RSL	9D	300 (raw value) Equivalent to 30.0000004470348 kmph	30.0000004470348 kmph To 140.000002086163 kmph	Road speed limit, mandated by law.

Neutral Gear Input

This hardware input is used to indicate to the BBM that the transmission is in Neutral. The input is intended as a PTO interlock, although there are other BBM functions which can use this information.

Pin/Connector Information

Pin Name	I/O, Type	BBM ECU Pin No.	ELCE-CK Connector Pin
Neutral Gear Input	Input, Active Low	A24	Connector 4 Pin G

(a) Neutral Gear Input (pin A24) (Active Low Input)

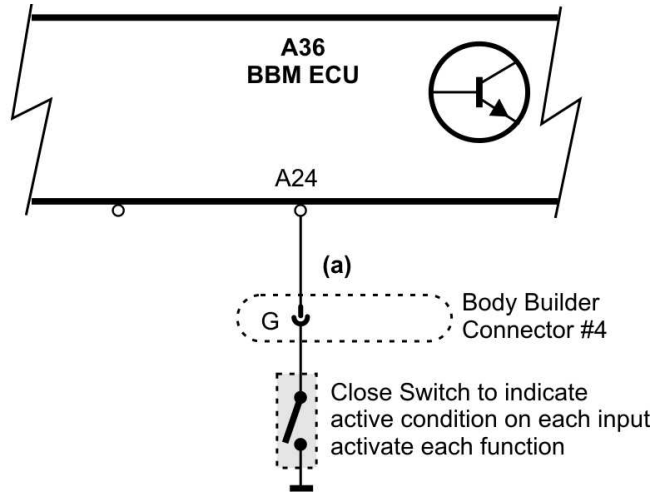

These inputs are required for some PTO settings depending on programming.

The switch should be normally open, and close automatically when the gearbox is placed in Neutral.

W3127857

Note: All grounds from ELCE-PK powered circuits connect to terminal A, connector 1.

Pre-requisites/Conditions for Activation

None. This is a status input for the BBM, not a command input.

Related BBM ECU Parameters/Setup for Premium Tech Tool 2

None.

Other Information/Notes

BBM ECU Functions which use this Neutral Gear Input information include:

- PTO Output Controls
- Engine Remote Start Enable Output
- Databus Triggered Output

Note: Refer to the appropriate section for the functions above to see how to use this input.

Note: If this input is called for in one of the functions above, and no physical wire is connected, the BBM will default to the state that the transmission is not in Neutral.

Note: At present, vendor transmissions used in the North American market will need to use the hardwired Neutral Input.

Low Split Gear Input

This hardware input is used to indicate to the BBM that the transmission is in a Low Split Gear. The input is intended as a PTO interlock.

Pin/Connector Information

Pin Name	I/O, Type	BBM ECU Pin No.	ELCE-CK Connector Pin
Low Split Gear Input	Input, Active Low	A28	Connector 4 Pin H

(a) LowSplit Gear Input (pin A28) (Active Low Input)

These inputs are required for some PTO settings depending on programming.

The switch should be normally open, and close automatically when the gearbox is placed in a LowSplit gear.

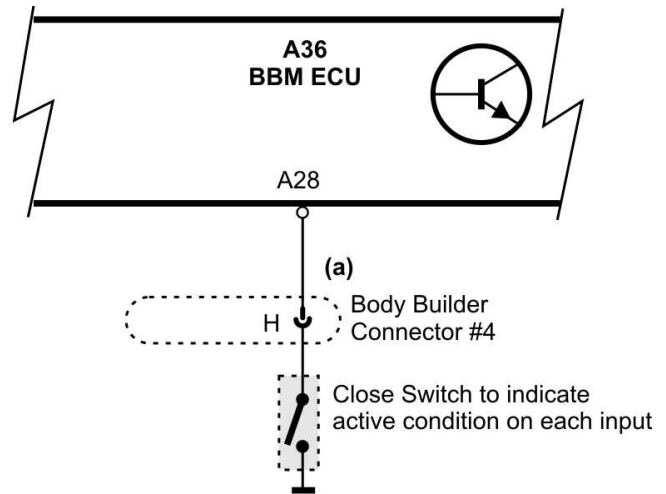

W3127858

Note: All grounds from ELCE-PK powered circuits connect to terminal A, connector 1.

Pre-requisites/Conditions for Activation

None. This is a status input for the BBM, not a command input.

Related BBM ECU Parameters/Setup for Premium Tech Tool 2

None.

Other Information/Notes

The only use for this input by the BBM ECU is as a PTO interlock.

Note: Refer to the appropriate section for the functions above to see how to use this input.

Note: If this input is called for in the PTO Output Control function, and no physical wire is connected, the BBM will default to the state that the transmission is not in Low Split Gear.

Note: At present, vendor transmissions used in the North American market will need to use the hardwired input.

Split Shaft (Split Box) PTO Input

The input is used when a split-shaft PTO (or other drive-shaft powered PTO) is engaged in order to temporarily disable (a), use of the transmission output shaft as the vehicle speed source, and (b), any engine speed limitation which would result from apparent (indicated) road speed being seen from the transmission output shaft. This causes the VECU to temporarily revert to the ABS system to determine road speed.

Pin/Connector Information

Pin Name	I/O, Type	BBM ECU Pin No.	ELCE-CK Connector Pin
Split Shaft PTO Input	Input, Active High	A29	Connector 4 Pin J

(a) Splitshaft PTO Input (pin A29)
(Active High Input)

(b) BBM-supplied +V Switch Supply

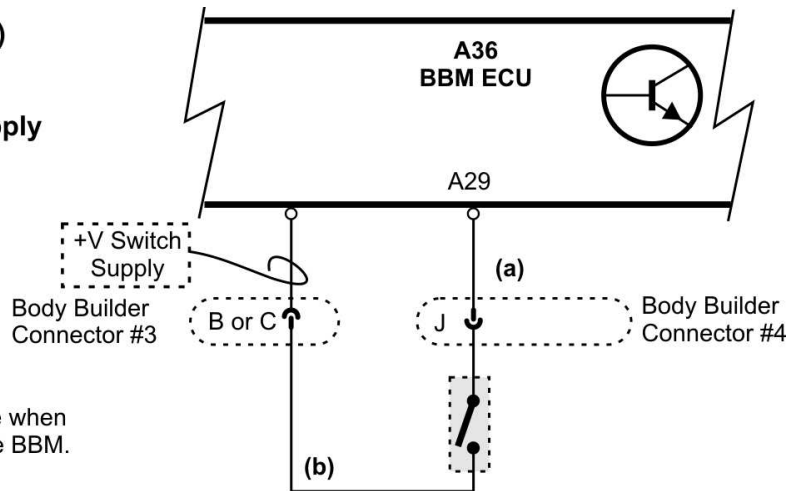

Active High Input; Switch should close when SplitBox PTO is engaged to inform the BBM.

W3127859

Pre-requisites/Conditions for Activation

- The function is enabled (Parameter BRQ) for VECU.
- Park brake must be applied.
- Split Shaft PTO Input pin must be active.
- If vehicle is equipped with ABS system, then ABS system must report wheel speed on J1587 datalink, and that wheel speed must be zero.

Notes

Related BBM ECU Parameters/Setup for Premium Tech Tool 2

Parameter Name	Code	Default Value	Range	Description
F_ENABLE_SPLIT_BOX	BRQ	0	0/1	Informs the BBM VECU whether to use the input A29.
F_PARK_ENABLE	LJL	1	0/1	Park brake switch, PTO exit cond. Enable park brake switch as exit condition for Split box PTO session. Parameter Value "No" - Park brake switch is NOT considered as an exit condition for Split box Parameter Value "Yes" - Park brake switch "Released" is considered as an exit condition for Split box.
F_SPEED_ENABLE	LJM	1	0/1	ABS vehicle speed condition enable. Enable and disable the ABS or EBS vehicle speed condition while exiting Split box session. Parameter Value "No" – ABS or EBS vehicle speed is NOT considered as an exit condition for Split box Parameter Value "Yes" – ABS or EBS vehicle speed is considered as an exit condition for Split box.

Notes

Remote Throttle/2nd Accelerator Pedal

This function is used to provide either a 2nd Accelerator Pedal (for dual-drive applications) or a Remote Throttle control (for stationary applications). The interface consists of inputs for the AccPedal / Throttle Control device, plus an input to switch between the primary and secondary controls. While the secondary controls are selected, the primary accelerator pedal is ignored.

If used as part of a second driving position setup, an Idle Validation Switch (IVS) must be used as a part of the 2nd Accelerator Pedal. While the 2nd Accelerator Pedal is active, a "2nd AccPedal Road Speed Limit" (RSL) is applied.

If used as part of a Remote or "Hand" Throttle which will only be used in stationary applications, no IVS input is required. However, the enable circuit must be wired through a normally closed pressure switch plumbed to the Park Brake air circuit such that the Remote Throttle can only be selected when the park brake is applied.

Note: The body builder is responsible for adding the Parking Brake air switch for stationary applications.

Note: The 2nd-pedal IVS input is not brought out to the Body Builder connector in variant ELCE-CK - only the 2nd AccPedal inputs themselves, as the typical use for this input will be as a stationary Remote Throttle.

Pin/Connector Information

Pin Name	I/O Type	BBM ECU Pin No.	ELCE-CK Connector Pin	Comment
2nd Acc/Remote Throttle Enable Input	Input, Active Low	B12	Connector 4 Pin K	
2nd Acc/Remote Throttle Sensor Supply (Vref)	Output, 5V supply	B10	Connector 4 Pin L	Keep added wires as short as possible, and use twisted-trio wires to prevent noise pickup.
2nd Acc/Remote Throttle Sensor Input	Input, Analog	B9	Connector 4 Pin M	
2nd Acc/Remote Throttle Ground Reference	Sensor Ground	B22	Connector 4 Pin N	
2nd Accelerator Pedal IVS Switch Power	Switch Power (~Vbatt)	B19	Connector 3 Pin C	Use for BBM-connected switches ONLY!
2nd Accelerator IVS Input	Input, Active High	B30	N/A	Not used in ELCE-CK.

Notes

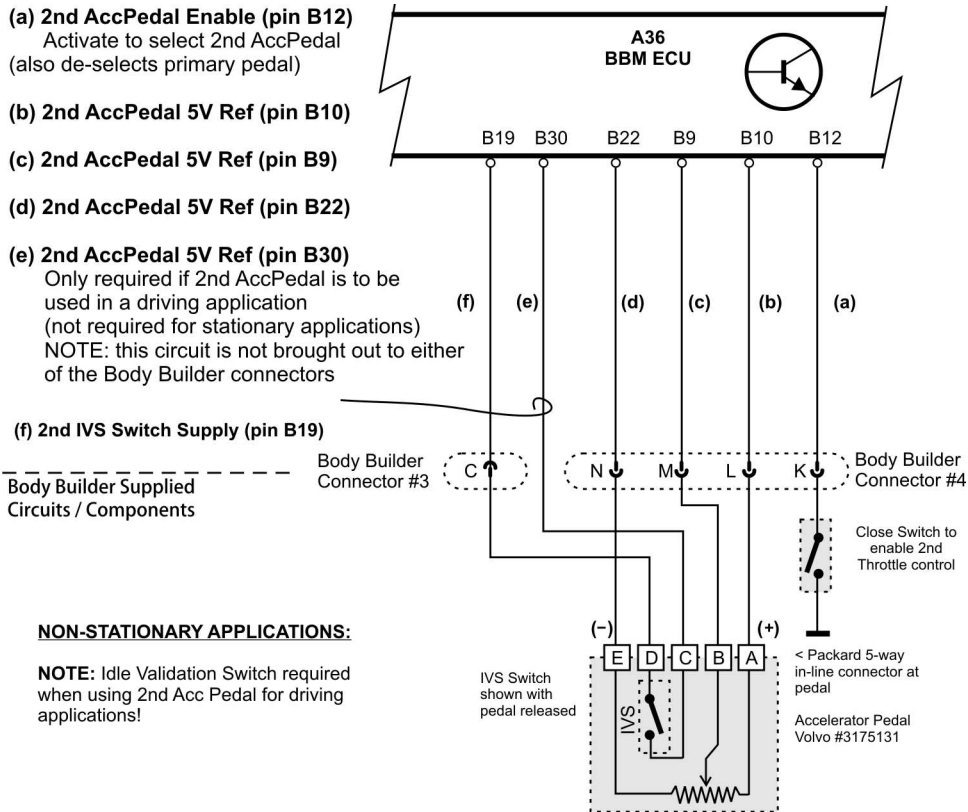

W3127860

Note: All grounds from ELCE-PK powered circuits connect to terminal A, connector 1.

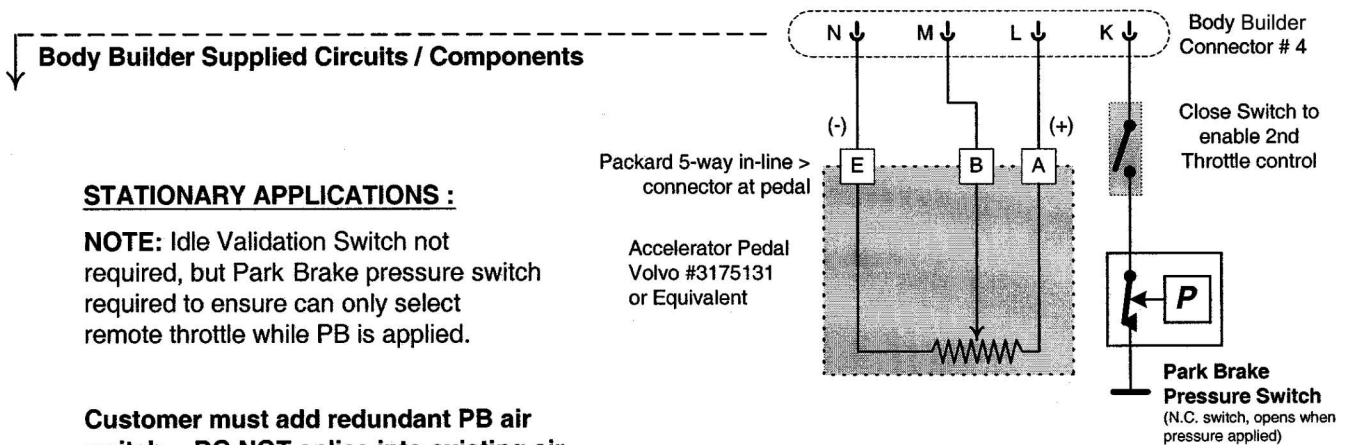

W3127861

Note: All grounds from ELCE-PK powered circuits connect to terminal A, connector 1.

Pre-requisites/Conditions for Activation

- Function must be enabled in the BBM.
- 2nd accelerator pedal enable input pin must be active.
- If used as 2nd accelerator pedal, must have sensor properly interfaced including IVS.
- If used as Remote Throttle (stationary only), no IVS is needed.
- Pedal/Throttle control must be at 0 % position immediately after being enabled before the values are used. This prevents switching over when the 2nd pedal is held 'off-idle'.

Related BBM ECU Parameters/Setup for Premium Tech Tool 2

Parameter Name	Code	Default Value	Range	Description
ACC_SECOND_PEDAL_ENABLE	EE	0 (OFF)	0/1	Enables the second pedal/throttle control input, and activates 2nd Pedal Road Speed Limit.
ACC_SECOND_PEDAL_RSL	GO	20 km/h (12 mph)	5 - 140 km/h (3 - 87 mph)	This RSL is imposed while the 2nd Accelerator Pedal is enabled.
HANDTHROTTLE_ACTIVE	ZX	0 (OFF)	0/1	Should be set when this function is used as a Remote/Hand Throttle used for stationary applications ONLY! BBM ECU will ignore the 2nd IVS input.
HANDTHROTTLE_100_PERC	ZZ	823	0-1023, (0-5V)	Hand throttle, upper limit. This parameter sets the corresponding analogue value from the hand throttle potentiometer to the upper limit value 100%.
HANDTHROTTLE_ZERO_PERC	ZY	200	0-1023, (0-5V)	Hand throttle, lower limit. This parameter sets the corresponding analogue value from the hand throttle potentiometer to the lower limit value 0%.
HANDTHROTTLE_MIN_RNG_LIM	AER	100	0-1023, (0-5V)	Defines the low diagnostic limit for the Remote / 2nd Throttle input. Readings below (or above) these readings will set a fault code.
HANDTHROTTLE_MAX_RNG_LIM	AES	923	0-1023, (0-5V)	Defines the high diagnostic limit for the Remote / 2nd Throttle input. Readings below (or above) these readings will set a fault code.
F_ENABLE_GEAR_LEVER_EXTRA	AIB	0 (OFF)	0/1	Enable extra gear lever. This parameter governs the condition for extra gear lever functionality.

Other Information/Notes

The throttle sensor / control used must have a total resistance of 1 k Ω (1kO hm) minimum; for ease of interfacing, it is suggested to simply use an accelerator pedal identical to that already installed in the vehicle (Volvo part number 85111239 or equivalent).

A simple potentiometer will generally not function properly in this application, since the BBM ECU will set fault codes if the input signal goes lower than ~ 10%, or higher than ~ 90%, of Vref. In order to prevent this, either:

- Use the recommended Throttle Control.
- Use an automotive-style TPS (Throttle Position Sensor).
- Insert small fixed-value resistors on either side of the potentiometer to limit the signal swing.
- If a simple potentiometer must be used (allowed in stationary applications only), then additional parameter settings will be needed to change the scaling and mapping of the remote control, see BBM Customer Parameter listing at the end of this document.

There are additional parameters not shown above which may be used to tailor the scaling, range, and response of the throttle control. The default values will work in all cases if a standard Accelerator Pedal (31751531) or automotive-style TPS is used, but contact Customer Engineering for assistance in changing the scaling / mapping parameters if needed.

Note: Improper setting of the scaling / mapping parameters will make this function unusable!

Notes

Road Speed (C3) Output

This output can be used to either provide a road speed proportional frequency output, or can be programmed to act as a switched output based on the vehicle speed going above or below a specific value. Regardless of which type of output this pin is configured for, this pin is an active high output (load should be ground-referenced), and is capable of supplying a maximum of 1 Amp.

Frequency Output: This is the output signal of a tachograph. We use it to provide a buffered reproduction of the 16 pulse-per-revolution Vehicle Speed Sensor (VSS) signal from the transmission output shaft. Knowing the axle gear ratio and tire revolutions per mile, one can calculate Vehicle Speed from this signal.

Speed Switched Output: This mode allows programming the output as a vehicle speed dependent switch.

Pin/Connector Information

Pin Name	I/O, Type	BBM ECU Pin No.	ELCE-CK Connector Pin	Comment
Road Speed (C3) Output	Output, Active High	B28	Connector 4 Pin P	Load driven by this pin should be ground-connected; 1A max

Pre-requisites/Conditions for Activation

- Road Speed (C3) Output parameter must be enabled in the BBM.
- No vehicle speed related faults in VECU or BBM ECU.
- Specify vehicle speed where switching occurs. This is required only to get the output to operate as speed-switched output.

Parameter Name	Code	Default Value	Range	Description
F_ENABLE_C3_OUTPUT	GT	0 (OFF)	0/1	
C3_DIGITAL_ACT_VSPD	LV	0 km/h (0 mph)	0-140 km/h (0-87 mph)	If 0, specifies C3 output operates in "frequency output" mode. If value other than 0, indicates the output operates as a speed dependent switch (switching at speed indicated...)
C3_DIGITAL_INV_FUNC	SD	0 (OFF)	0/1	See Other Information/Notes
C3_RPM_FRQ_CONST	CZT	17	2 - 72	Frequency related engine speed output conv. Factor. BBM provides a FM (frequency modulated) signal on one output pin that is proportional to the engine speed for body builder purposes. This parameter modifies the output frequency according to the formula $f = \text{rpm} * z / 100$ where z is the value of parameter CZT (default 17).

Other Information/Notes

Frequency Output

The relationship between the output frequency (pulses per second) of the C3 signal, and the actual vehicle speed, can be determined knowing the rear-axle gear ratio and the tire revs/mile:

$$\text{Veh Speed (km/h)} = (410.383 \times C3) / (GR \times T) \quad [\text{Veh Speed (MPH)} = (225 \times C3) / (GR \times T)]$$

Where:

C3 = frequency of C3 signal (in Hz, or pulses / second)

GR = rear axle Gear Ratio (e.g., 3.90)

T = Tire revolutions per mile, from tire mfg data (e.g., 500 revs/mile)

If tire data is expressed in (revolutions per kilometer) instead of (revolutions per mile), then the result will be Vehicle speed in km/h (KPH).

To determine what the output frequency will be for a given vehicle speed, you can turn around the equation above to give:

$$\text{Output Frequency (Hz)} = (GR \times T \times \text{VehSpeed}) / 410.383 = 1 / TTOTAL \quad [\text{Output Frequency (Hz)} = (GR \times T \times \text{VehSpeed}) / 225 = 1 / TTOTAL]$$

The waveform at the output pin will look similar to:

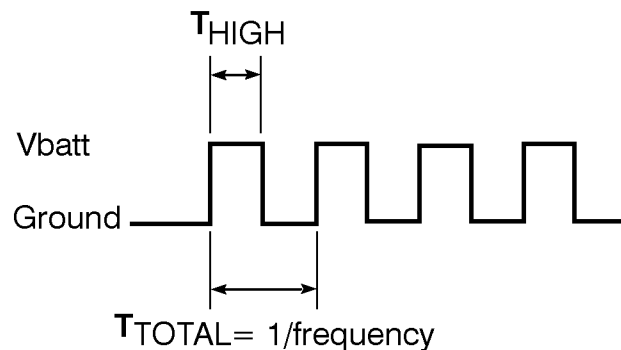

W3005677

The Frequency output is equal to $(1 / TTOTAL)$ as indicated above. The time-high (T_{HIGH}), remains fixed for a given vehicle, it is only the time-low that lengthens or shortens (resulting in different $TTOTAL$) with different speeds. Since the duty cycle of the output signal changes with speed as well as the frequency, an average DC-volts measurement, proportional to speed, is also possible.

Due to the lower frequencies which would need to be generated for extremely slow vehicle speeds, the Frequency Output has a usable lower limit of approximately 3 km/h (~2 MPH). Below this speed, the output will be off (grounded) all of the time.

Speed Switched Output

When configured for this mode of operation (by setting C3_DIGITAL_ACT_VSPD to a non-zero value), the output acts as a digital output with the following characteristics: (assuming C3_DIGITAL_INV_FUNC = 0)

- Output goes HIGH if Vehicle Speed > parameter C3_DIGITAL_ACT_VSPD
- Output goes LOW if Vehicle Speed < parameter C3_DIGITAL_ACT_VSPD

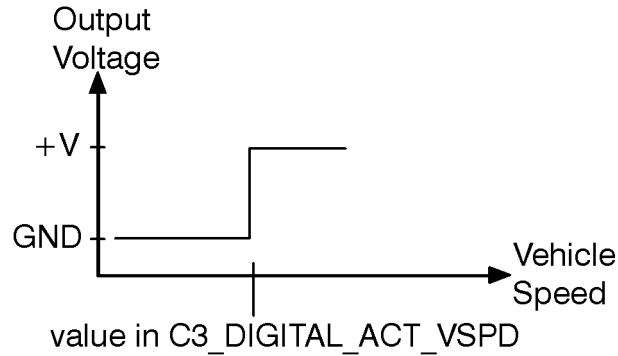

W3005678

If parameter C3_DIGITAL_INV_FUNC is turned on, then the inverse of the above states will result:

- Output goes LOW if Vehicle Speed > parameter C3_DIGITAL_ACT_VSPD
- Output goes HIGH if Vehicle Speed < parameter C3_DIGITAL_ACT_VSPD

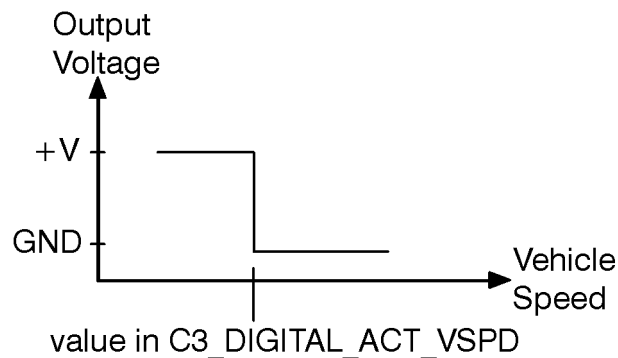

W3005679

System Warning Output

Provides an output (active low, maximum 1 Amp) which becomes active when a J1587 fault with FMI 0 (higher than normal) or FMI 1 (lower than normal) is set by the corresponding ECU:

- High Engine Coolant Temperature
- Low Engine Coolant Level
- Low Engine Oil Level
- High Engine Oil Temperature
- Low Engine Oil Pressure
- High Engine Crankcase Pressure
- High Transmission Oil Temperature (Available with Allison Transmissions only)

Each condition (fault) above may be individually enabled/disabled. If more than one is enabled, the output becomes an 'OR' of the enabled inputs.

Applications for this output would be to give an audible or visual alert to some condition which could affect the operation of auxiliary equipment. With proper interfacing, it could also be used to turn off / disconnect certain equipment in the event of a problem with the engine or transmission.

Pin/Connector Information

Pin Name	I/O, Type	BBM ECU Pin No.	ELCE-CK Connector Pin	Comment
System Warning Output	Output, Active Low	B16	Connector 4 Pin R	Load driven by this pin should be +V connected; 1A maximum

(a) System Warning Output (pin B16)
(Active Low Output, 1Amp Maximum)

(a) Databus Triggered Output (pin B18)
(Active Low Output, 1Amp Maximum)

Either output can drive a Lamp, Buzzer or Relay load.

Observe maximum current of 1 Amp.

If the load has polarity marks (such as most buzzers), be sure:

- * (+) side or RED lead goes toward IGN or BAT,
- * (-) side or BLACK lead towards the BBM ECU.

For +V-connected loads, customer is to supply a fuse of appropriate size, connected to +IGNITION or V_{batt}.
DO NOT use the BBM ECU supplied voltage (Body Builder Connector #3, pins B or C) for powering devices connected to BBM Outputs.

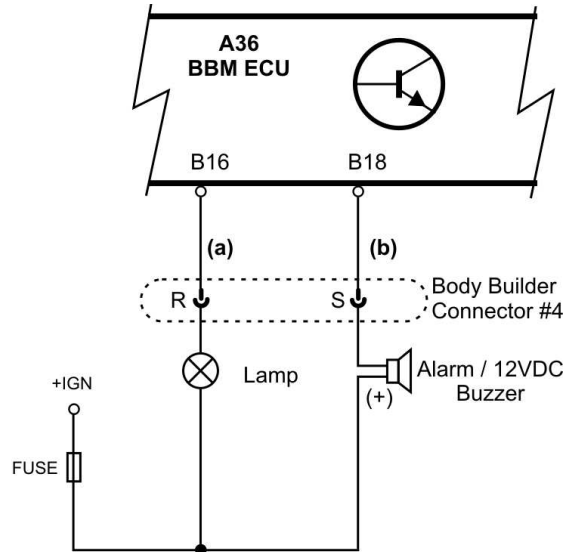

W3127862

Pre-requisites/Conditions for Activation

- One (or more) parameter(s) turned ON to indicate which faults will trigger the warning.
- The output is de-activated for 30 seconds following initial power-up (to avoid warning activation based on 'old' fault codes).

Parameter Name	Code	Default Value	Range	Description
F_ENG_COOLANT_TEMP_WARNING_ON	AEL	0(OFF)	0/1	Engine Coolant Temperature
F_PID111_WARNING_ON	AEM	0 (OFF)	0/1	Engine Coolant Level
F_PID98_WARNING_ON	AEI	0 (OFF)	0/1	Engine Oil Level
F_PID175_WARNING_ON	AEP	0 (OFF)	0/1	Engine Oil Temperature
F_PID100_WARNING_ON	AEJ	0 (OFF)	0/1	Engine Oil Pressure
F_PID153_WARNING_ON	AEK	0 (OFF)	0/1	Engine Crankcase Pressure
F_PID124_WARNING_ON	AEO	0 (OFF)	0/1	Transmission Oil Level
F_PID177_WARNING_ON	AEN	0 (OFF)	0/1	Transmission Oil Temperature (Usable w/ Allison Transmissions ONLY)

Turning one (or more) of the parameters above "on" (1) will include that warning in the logic which is used to activate the System Warning Output.

Note: Parameter AEN (F_PID177_WARNING_ON) for Transmission Oil Temperature, is usable with Allison Transmissions only.

Notes

Databus Triggered Output

Provides an output (active low, maximum 1 Amp) which becomes active when any of the following databus parameters match programmed values:

- Engine RPM > programmed value
- Output Shaft Speed > programmed value
- Vehicle Speed > programmed value
- Selected Gear = Neutral

Setting the programmed values to 0 disables that condition. If two or more values are programmed, an "OR" condition will result.

Note that this function will be disabled if there are any J1939 databus-related fault codes in the BBM.

Applications for this output would be as an RPM or Vehicle Speed triggered output, or to enable/ disable certain functions when specified conditions are met.

Pin/Connector Information

Pin Name	I/O, Type	BBM ECU Pin No.	ELCE-CK Connector Pin	Comment
Databus Triggered Output	Output, Active Low	B18	Connector 4 Pin S	Load driven by this pin should be +V connected; 1A maximum

(a)System Warning Output (pin B16)
(Active Low Output, 1Amp Maximum)

(a)Databus Triggered Output (pin B18)
(Active Low Output, 1Amp Maximum)

Either output can drive a Lamp, Buzzer or Relay load.

Observe maximum current of 1 Amp.

If the load has polarity marks (such as most buzzers), be sure:

- * (+) side or RED lead goes toward IGN or BAT,
- * (-) side or BLACK lead towards the BBM ECU.

For +V-connected loads, customer is to supply a fuse of appropriate size, connected to +IGNITION or Vbatt.
DO NOT use the BBM ECU supplied voltage (Body Builder Connector #3, pins B or C) for powering devices connected to BBM Outputs.

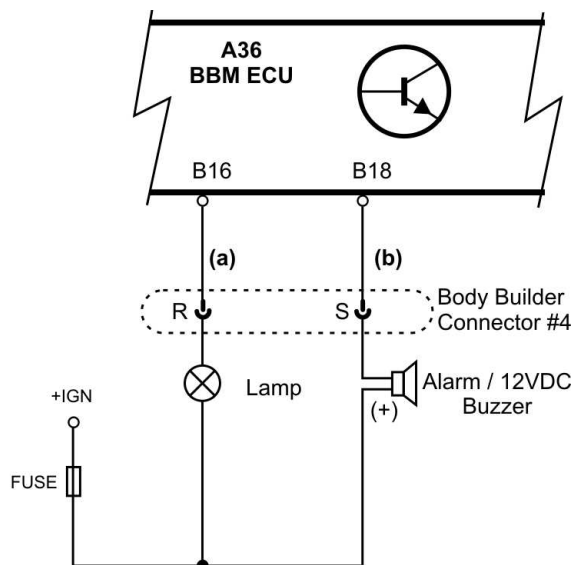

W3127862

Pre-requisites/Conditions for Activation

- One (or more) parameter(s) turned ON to indicate which conditions will trigger the output.
- No J1939 Databus-related fault codes in the BBM ECU.

Parameter Name	Code	Default Value	Range	Description
ENGINE_RPM_TRIG	ADA	0 (OFF)	0-2500 RPM	
OUTPUT_SHAFT_RPM_TRIG	ADB	0 (OFF)	0-2500 RPM	
VEHICLE_SPEED_TRIG	ADC	0 (OFF)	0-130 km/h (0-80 mph)	
GEAR_IN_NEUTRAL	AHZ	0 (OFF)	0/1	Use hardwired NEUTRAL input for this function
ENGINE_SPEED_HYSTERESIS	PDN	10 RPM	0-1000 RPM	Warning triggered if Engine speed exceeds ADA
VEHICLE_SPEED_HYSTERESIS	PDP	2 km/h (1 mph)	0-100 km/h (0 - 62 mph)	Warning triggered if Vehicle speed exceeds ADC
OUTPUT_SHAFT_SPEED_HYSTERESIS	PDO	10 RPM	0-1000 RPM	Warning triggered if Output shaft speed exceeds ADB

Making one (or more) of the parameters above non-zero will include that condition in the logic which is used to activate the output.

Note: The Neutral gear hardwire input (BBM ECU pin A24) must be used if the GEAR_IN_NEUTRAL parameter is used.

Notes

PTO Engine Speed Control Inputs

Hardwire activation of up to four (4) pre-programmed PTO set speeds is done using the PTO_Mode1, PTO_Mode2, PTO_Mode3, and PTO_Mode4 inputs of the BBM.

The PTO_Mode1 input acts on the PTO inside the VECU, but provides additional capabilities in terms of input activation and interlocks.

The PTO_Mode2 through _Mode4 inputs use the PTO functions of the BBM ECU. Only one PTO Set Speed can be active at a time.

If multiple inputs are active at once, they are serviced on a "first come, first served" basis.

The PTO set speeds can be programmed with multiple options. Each of the 4 PTO set speeds are set up identically and independently in the BBM ECU. Programmable features include:

- Inputs may be setup as either LEVEL or EDGE triggered
- Exit time delay may be specified for each input
- Entry / Exit ramp (rpm / second) may be specified
- Park-brake interlock
- Requirement (or not) that one of the PTO "dash switch" Inputs is active (Refer to "PTO Output Control (Inputs and Outputs)", page 120)

Once the BBM's Engine Speed Control function is active, the set-speed may be adjusted up/down by use of either the Remote PTO Speed INC/DEC inputs (Refer to "PTO Engine Speed Increment/Decrement Inputs", page 119), or by use of the stalk-mounted Set(+) and Set(-) switches.

Pin/Connector Information

Pin Name	I/O, Type	BBM ECU Pin No.	ELCE-CK Connector Pin	Comment
PTO Mode 1 Input	Input, Active High	A4	Connector 3 Pin G	Acts on PTO1 inside VECU
PTO Mode 2 Input	Input, Active High	B21	Connector 3 Pin H	Acts on PTO2 inside BBM
PTO Mode 3 Input	Input, Active High	A3	Connector 3 Pin J	Acts on PTO3 inside BBM
PTO Mode 4 Input	Input, Active High	A5	Connector 3 Pin K	Acts on PTO4 inside BBM

Pre-requisites/Conditions for Activation

- One of the PTO_ModeX_Enable parameters must be enabled.
- The corresponding PTO ModeX input must be activated.
- The engine speed must be > 0, and no engine speed related fault codes present.
- Any programmed conditions, as determined by parameter settings for the corresponding PTO ModeX, must be satisfied (e.g., Park brake, PTO dash switch, etc.).
- The first time that the PTO ModeX input is activated each ignition cycle, the BBM ECU must see the input go OFF, then ON, before it will engage the corresponding PTO Engine Speed Control. This is to prevent a switch which was accidentally left "on" from automatically engaging the PTO.

Related BBM ECU Parameters/Setup for Premium Tech Tool 2

Note: Each of the 4 PTO Engine Speed Control functions are set up identically and independently; the table below lists parameters which apply to all 4 PTO EngSpeedCtrl modes, then lists the parameters for each of the 4 modes separately.

Note: The descriptions for each of PTO_MODEx parameters are immediately following the table.

Parameter Name	Code	Default Value	Range	Description
PTO_MIN_ENGINE SPEED	DC	500 RPM	500 - 2500 RPM	See descriptions following table
PTO_MAX_ENGINE SPEED	AA	2500 RPM	500 - 3500 RPM	
PTO_ENGINE_ADJUST_RAMP	IF	50 RPM per second	0 - 250 RPM per second	Applies when either INC or DEC input is held
PTO_MODE1_ENABLE	IC	1	0/1	Enables PTO Mode 1 Input
PTO_MODE1_DEF_RES_ESPD	HB	800 RPM	500 - 2500 RPM	See descriptions following table
PTO_MODE1_EDGE_TRIG_ENABLE	YJ	1	0/1	
PTO_MODE1_SW_COND_ENABLE	HT	0	0/1	
PTO_MODE1_BRAKE_ENABLE	BRR	0	0/1	
PTO_MODE1_CLUTCH_ENABLE	BRV	0	0/1	
PTO_MODE1_PARKBR_COND_ENABLE	HH	1	0/1	
PTO_MODE1_DELAY	HE	0 Second	0 - 25 Seconds	
ESM_MODE_ENTRY_RAMP	IHV	0 RPM per second	0 - 250 RPM per second	
ESM_MODE_EXIT_RAMP	IHW	0 RPM per second	0 - 250 RPM per second	
PTO_MODE2_ENABLE	ID	1	0/1	Enables PTO Mode 2 Input
PTO_MODE2_DEF_RES_ESPD	HC	1000 RPM	500 - 2500 RPM	See descriptions following table
PTO_MODE2_EDGE_TRIG_ENABLE	YK	1	0/1	
PTO_MODE2_SW_COND_ENABLE	HU	0	0/1	
PTO_MODE2_BRAKE_ENABLE	BRS	0	0/1	
PTO_MODE2_CLUTCH_ENABLE	BRW	0	0/1	
PTO_MODE2_PARKBR_COND_ENABLE	HI	1	0/1	
PTO_MODE2_DELAY	HF	0 Second	0 - 25 Seconds	
PTO_OUT2_MAX_ROAD_SPEED	EAR	161 KMPH (100 mph)	5 - 255 KMPH (3 - 158 mph)	
PTO_MODE3_ENABLE	IE	1	0/1	Enables PTO Mode 3 Input
PTO_MODE3_DEF_RES_ESPD	HD	1200 RPM	500 - 2500 RPM	See descriptions following table

Parameter Name	Code	Default Value	Range	Description
PTO_MODE3_EDGE_TRIG_ENABLE	YL	1	0/1	
PTO_MODE3_SW_COND_ENABLE	HV	0	0/1	
PTO_MODE3_BRAKE_ENABLE	BRT	0	0/1	
PTO_MODE3_CLUTCH_ENABLE	BRX	0	0/1	
PTO_MODE3_PARKBR_COND_ENABLE	HJ	1	0/1	
PTO_MODE3_DELAY	HG	0 second	0 - 25 Seconds	
PTO_OUT3_MAX_ROAD_SPEED	EAS	161 KMPH (100 mph)	5 - 255 KMPH (3 - 158 mph)	
PTO_MODE4_ENABLE	YO	1	0/1	Enables PTO Mode 4 Input
PTO_MODE4_DEF_RES_ESPD	YN	1400 RPM	must be within a window defined by parameters DC-AA	See descriptions following table
PTO_MODE4_EDGE_TRIG_ENABLE	YM	1	0/1	
PTO_MODE4_SW_COND_ENABLE	YP	0	0/1	
PTO_MODE4_BRAKE_ENABLE	BRU	0	0/1	
PTO_MODE4_CLUTCH_ENABLE	BRY	0	0/1	
PTO_MODE4_PARKBR_COND_ENABLE	YQ	1	0/1	
PTO_MODE4_DELAY	YR	0 second	0 - 100 second	
PTO_OUT4_MAX_ROAD_SPEED	EAT	161 KMPH (100 mph)	5 - 255 KMPH (3 - 158 mph)	
PTO_OUT2_ENGINE_MIN_SPEED	IGF	500 RPM	500 – 1500 RPM	
PTO_OUT3_ENGINE_MIN_SPEED	IGG	500 RPM	500 – 1500 RPM	
PTO_OUT4_ENGINE_MIN_SPEED	IGH	500 RPM	500 – 1500 RPM	
PTO_OUT2_ENGINE_SPEED_INCREASING_RAMP	IHP	0	0 – 250 rpm/s	
PTO_OUT3_ENGINE_SPEED_INCREASING_RAMP	IHQ	0	0 – 250 rpm/s	
PTO_OUT4_ENGINE_SPEED_INCREASING_RAMP	IHR	0	0 – 250 rpm/s	
PTO_OUT2_ENGINE_SPEED DECREASING_RAMP	IHS	0	0 – 250 rpm/s	
PTO_OUT3_ENGINE_SPEED DECREASING_RAMP	IHU	0	0 – 250 rpm/s	
PTO_OUT4_ENGINE_SPEED DECREASING_RAMP	IHT	0	0 – 250 rpm/s	

Parameter Name	Code	Default Value	Range	Description
ENGINE_SPEED_MODE_RESUME_SWITCH_TOGGLING	IFS	0	0/1	
BB_ENGINESPD_CONTROL	DWC	0	0/1	
ESM_MODE_ENTRY_RAMP	IHV	0	0 – 250 rpm/s	
ESM_MODE_EXIT_RAMP	IHW	0	0 – 250 rpm/s	
F_ENABLE_ESC_BBCAN_BRAKE_SWITCH	NWT	1	0/1	

Parameter Name	Description
PTO_MIN_ENGINE SPEED	MIN and MAX Allowed EngSpd that will be allowed when adjusting the PTO set speed using the BBM's PTO SPEED INC and DEC Inputs; Note MINIMUM must be < MAXIMUM. See similar parameters in the VECU which are used when CC SET(+) / SET(-) used to adjust PTO speed.
PTO_MAX_ENGINE SPEED	
PTO_MODEx_ENABLE	Enables the corresponding PTO Speed Control Input.
PTO_MODEx_DEF_RES_ESPD	Specifies the default pre-set Engine Speed which will be requested when the corresponding PTO Speed Ctrl Input is activated. Range is 500 ~ 2500 RPM for all PTOs, but must be within the MIN and MAX Engine Speeds specified above.
PTO_MODEx_EDGE_TRIG_ENABLE	Specifies whether the Inputs will be treated as LEVEL triggered (0) or EDGE triggered (1). See explanation below.
PTO_MODEx_SW_COND_ENABLE	Specifies whether or not one of the PTO INPUT/ENABLE Inputs (refer to PTO Outputs Control section) must be active before this PTO Engine Speed Control will engage. 0 = NO, 1 = YES (SEE NOTE BELOW)
PTO_MODEx_BRAKE_ENABLE	Specifies whether or not the service (foot) brake will have an effect on the engine speed control function: 0 = No (Pedal position makes no difference) 1 = Yes (Applying the service brake will kick out engine speed control)
PTO_MODEx_CLUTCH_ENABLE	Specifies whether or not the clutch pedal position will have an effect on the engine speed control function: 0 = No (Pedal position makes no difference) 1 = Yes (Applying the clutch pedal will kick out engine speed control)
PTO_MODEx_PARKBR_COND_ENABLE	Specifies whether or not the Park Brake must be applied before allowing speed control to be engaged. 0 = NO, 1 = YES
PTO_MODEx_DELAY	Specifies a time (in Seconds) to wait between when the Input is de-activated, and the PTO Speed Control mode is cancelled.
ESM_MODE_ENTRY_RAMP	Specifies a speed ramp (in RPM per Second) to use when engaging and disengaging the PTO Engine Speed Control. A value of '0' will result in a "step" function and may result in some over-shoot of the target engine speed.
ESM_MODE_EXIT_RAMP	Specifies a speed ramp (in RPM per Second) to use when engaging and disengaging the PTO Engine Speed Control. A value of '0' will result in a "step" function and may result in some over-shoot of the target engine speed.
PTO_OUT2_ENGINE_MIN_SPEED	Engine Speed Requested for PTO 2. When PTO 2 is engaged, BBM request this engine speed while PTO 2 is active. This is to avoid running at low speed.
PTO_OUT3_ENGINE_MIN_SPEED	Engine Speed Requested for PTO 3. When PTO 3 is engaged, BBM request this engine speed while PTO 3 is active. This is to avoid running at low speed.

Parameter Name	Description
PTO_OUT4_ENGINE_MIN_SPEED	Engine Speed Requested for PTO 4. When PTO 4 is engaged, BBM request this engine speed while PTO 4 is active. This is to avoid running at low speed.
PTO_OUT2_ENGINE_SPEED_INCREASING_RAMP	Increasing ramp PTO 2. Ramp value when trim to higher engine speed for PTO 2.
PTO_OUT3_ENGINE_SPEED_INCREASING_RAMP	Increasing ramp PTO 3. Ramp value when trim to higher engine speed for PTO 3.
PTO_OUT4_ENGINE_SPEED_INCREASING_RAMP	Increasing ramp PTO 4. Ramp value when trim to higher engine speed for PTO 4.
PTO_OUT2_ENGINE_SPEED DECREASING_RAMP	Decreasing ramp PTO 2. Ramp value when trim to lower engine speed for PTO 2.
PTO_OUT3_ENGINE_SPEED DECREASING_RAMP	Decreasing ramp PTO 3. Ramp value when trim to lower engine speed for PTO 3.
PTO_OUT4_ENGINE_SPEED DECREASING_RAMP	Decreasing ramp PTO 4. Ramp value when trim to lower engine speed for PTO 4.
ENGINE_SPEED_MODE_RESUME_SWITCH_TOGGLING	ESM Resume Enabled. Resume function helps to toggle between different engine speed values. 0= Default speed of the active engine speed mode is requested. 1= Toggle engine speed between the previous engine speed adjustment of the currently active engine speed mode and the default activation engine speed for the currently active engine speed mode.
BB_ENGINESPD_CONTROL	Activate control of engine speed by BB CAN. Activate control of engine speed control via CAN. Parameter DVE should be activated. 0 = No 1 = Yes
ESM_MODE_ENTRY_RAMP	Ramp up value for BBM ESM. This parameter is used to ramp up for all ESM modes.
ESM_MODE_EXIT_RAMP	Ramp down value for BBM ESM. This parameter value is used to ramp down for all ESM modes.
F_ENABLE_ESC_BBCAN_BRAKE_SWITCH	Inhibit control of engine speed by BB CAN on Brake. Inhibit control of engine speed control via Body builder CAN if the brake pedal is depressed.

Note: Regarding the "PTO_MODEx_SW_COND_ENABLE" parameters: The criteria is whether any one of the PTO INPUT/ENABLE Inputs is active, not necessarily the input that corresponds to this (numbered) PTO Engine Speed Control.

Notes

Other Information/Notes

When adjusting the PTO Engine Speed using the BBM's "Remote PTO Engine Speed INC/DEC" Inputs, the MIN and MAX engine speed limits given in the table above will apply. It is also possible to adjust the PTO set speed by using the Cruise Control SET+ and SET- buttons, though different limits (MIN and MAX engine speed while in PTO) will apply. Refer to the VECU PTO description for more information on these limits.

LEVEL versus EDGE triggering of the PTO Engine Speed Control Inputs:

LEVEL triggering will auto-resume PTO operation if it gets bumped out for any reason, while EDGE triggering will require a new "Input Off/Input On" activation sequence.

Note that one of the pre-requisites for Input activation is that: "The first time that the PTO ModeX input is activated each ignition cycle, the BBM ECU must see the input go OFF, then ON, before it will engage the corresponding PTO Engine Speed Control." This is to prevent a switch which was accidentally left "on" from automatically engaging PTO the next time the vehicle is started. Due to this, it is important to use the BBM's own "switch supply" outputs (pins B5 and B19, which are also found at ELCE-CK connector #3, pins A and B) as the voltage source used to activate all BBM Inputs. If another voltage source is used (for example, one that drops out during cranking), the BBM ECU may inadvertently think that the Input signal has been switched 'off', then back 'on'.

It is possible to have multiple PTO inputs active at the same time, although only one will be engaged at a time. The first to be activated will stay engaged until it is de-activated, regardless of activity on the other inputs. If a PTO is disengaged while other PTO inputs are active, the "next in line" will take effect, depending on the order in which they were activated.

The PTO modes of the BBM ECU have priority over the 'Stalk PTO' function of the VECU. If the Stalk PTO was active before engaging one of the BBM ECU PTO modes, the BBM ECU PTO will take effect but the Stalk PTO function will be restored after all BBM ECU PTO modes are dis-engaged.

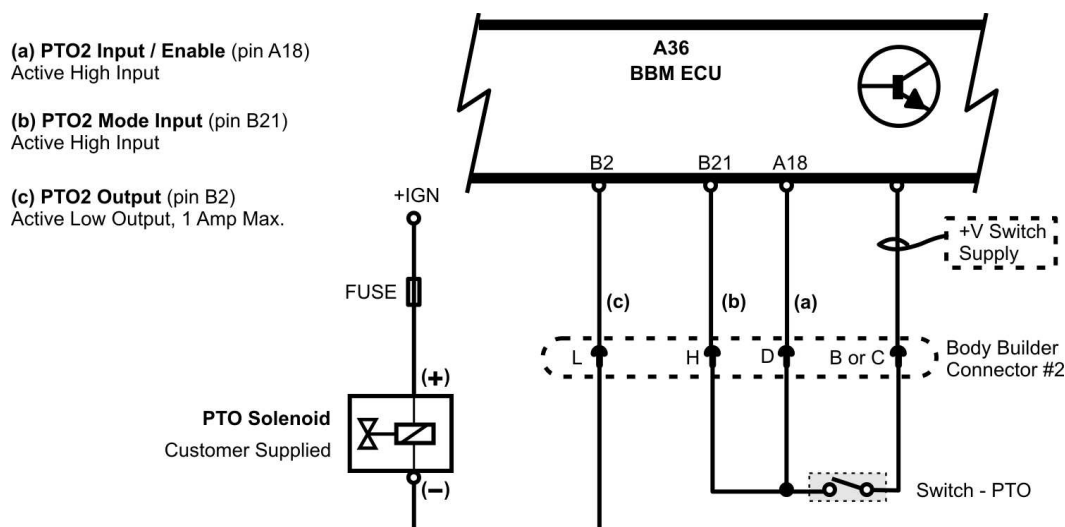

Wired as Shown, closing the switch will both engage PTO2 engine speed control, and drive the PTO2 output (energizing the PTO solenoid) when all programmed conditions are met.

Could also wire with two separate switches, one for engine speed control, and one for PTO Output control.

W3127864

Note: BBM also has the ability to engage the Volvo I-Shift PTO via the data link.

PTO Engine Speed Increment/Decrement Inputs

Two inputs are provided to remotely INCRement or DECrement the PTO set speed while one of the PTO Engine Speed Control modes are active within the BBM ECU.

The adjusted PTO Engine Speed will be retained in memory until the ignition is turned off, or until the PTO Engine Speed Control mode changes.

Pin/Connector Information

Pin Name	I/O, Type	BBM ECU Pin No.	ELCE-CK Connector Pin
Remote PTO Engine Speed Decrement Input	Input, Active High	A1	Connector 3 Pin P
Remote PTO Engine Speed Increment Input	Input, Active High	A2	Connector 3 Pin R

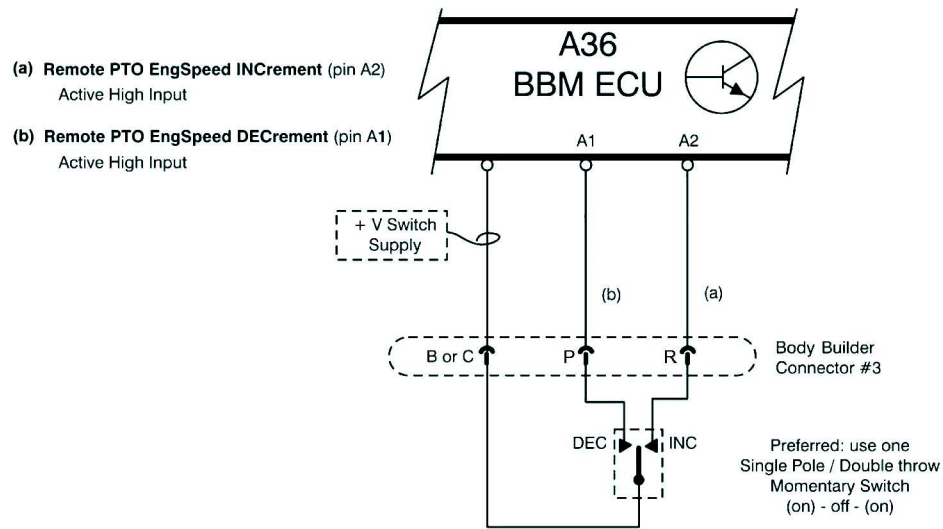

W3127865

Pre-requisites/Conditions for Activation

- One of the PTO Engine Speed Control modes must be active.
- One or the other (not both simultaneously) of the Remote PTO Engine Speed Inputs active.

Related BBM ECU Parameters/Setup for Premium Tech Tool 2

Parameter Name	Code	Default Value	Range	Description
PTO_MIN_ENGINE SPEED	DC	500 RPM	500 - 2500 RPM	Minimum allowed engine speed while in PTO; Note parameter DC must be < AA.
PTO_MAX_ENGINE SPEED	AA	2500 RPM	500 - 2500 RPM	Maximum allowed engine speed while in PTO; Note parameter AA must be > DC.
PTO_ENGINE_ADJUST_RAMP	IF	50 RPM per second	0 - 250 RPM per second	Applies when either INC or DEC input is 'held'.

PTO Output Control (Inputs and Outputs)

Three (3) pairs of Input / Output pins are available on the BBM for interfacing to PTO devices. (The VECU has its own PTO Input/Output pair, for a total of four when the BBM is fitted).

The outputs are used to control a PTO solenoid or bypass valve, and each is programmable to only allow the PTO to operate under specific conditions. The outputs are active low, and can sink up to 1 Amp maximum each.

The "Input / Enable" inputs are used to enable the Output drivers. They may be connected to dash switches, or driven by an external piece of equipment.

Each of the three PTO I/O pairs operate in an identical manner, and are independently programmable.

Pin/Connector Information

Pin Name	I/O, Type	BBM ECU Pin No.	ELCE-CK Connector Pin	Comment
PTO2 Input / Enable Input	Input, Active High	A18	Connector 3 Pin D	Also called "PTO2 Input / Dash Switch"
PTO3 Input / Enable Input	Input, Active High	A19	Connector 3 Pin E	Also called "PTO3 Input / Dash Switch"
PTO4 Input / Enable Input	Input, Active High	A20	Connector 3 Pin F	Also called "PTO4 Input / Dash Switch"
PTO2 Output	Output, Active Low	B2	Connector 3 Pin L	1 Amp maximum
PTO3 Output	Output, Active Low	B3	Connector 3 Pin M	1 Amp maximum
PTO4 Output	Output, Active Low	B4	Connector 3 Pin N	1 Amp maximum

Pre-requisites/Conditions for Activation

The purpose of the PTO outputs is to prevent engagement of the PTO device(s) until certain programmable conditions are in place. In order for a PTO output to become active, all of the following must occur:

- The corresponding "Input / Enable" input pin must be activated.
- The park brake must be set (programmable).
- Engine speed must be greater than a certain RPM (programmable) for at least two seconds.
- Engine speed must be less than a certain RPM (programmable; this prevents engaging of the PTO if engine is over speed).
- Vehicle speed must be below some maximum (programmable).
- Transmission must be in Neutral (programmable).
- Transmission must be in a Low Split gear (programmable).
- The first time that the PTO Input / Enable input is activated each ignition cycle, the BBM ECU must see the input go OFF, then ON, before it will engage the corresponding PTO output.

Related BBM ECU Parameters/Setup for Premium Tech Tool 2

Note: Each of the three PTO Output Control functions are set up identically and independently; the table below lists the parameters for each of the three modes separately.

Parameter Name	Code	Default Value	Range	Description
PTO_OUT2_ON_EDGE	YT	1	0/1	See descriptions following this table
PTO_OUT2_PARK_BRAKE	YU	0	0/1	
PTO_OUT2_NEUTRAL_GEAR	YV	0	0/1	
PTO_OUT2_LOWSPLIT_GEAR	YW	0	0/1	
PTO_OUTX_LEGAL_RSL	9D	300	300-1400 (Raw value)	
PTO_OUT2_ENGINE_SPEED_HIGH	YY	2500 RPM	500-2500 RPM	
PTO_OUT2_VEHICLE_SPEED	YZ	250 km/h (155 mph)	2-250 km/h (1-155 mph)	
PTO_OUT2_TYPE	ZA	4 Engine 2	0, 1, 2, 3, 4	
PTO_OUT2_ENG_LIM	ZB	0	0/1	
PTO_OUT2_MAX_ROAD_SPEED	EAR	250 km/h (155 mph)	0-250 km/h (0 -155 mph)	
PTO_OUT2_ENGINE_MIN_SPEED	IGF	500	500 - 1500 RPM	
PTO_OUT3_ON_EDGE	ZC	1	0/1	
PTO_OUT3_PARK_BRAKE	ZD	0	0/1	
PTO_OUT3_NEUTRAL_GEAR	ZE	0	0/1	
PTO_OUT3_LOWSPLIT_GEAR	ZF	0	0/1	
PTO_OUT3_ENGINE_SPEED_HIGH	ZH	2500 RPM	700-2500 RPM	
PTO_OUT3_VEHICLE_SPEED	ZI	250 km/h (155 mph)	2-250 km/h (1-155 mph)	
PTO_OUT3_TYPE	ZJ	1 Trans 1	0, 1, 2, 3, 4	
PTO_OUT3_ENG_LIM	ZK	0	0/1	
PTO_OUT3_MAX_ROAD_SPEED	EAS	250 km/h (155 mph)	0-250 km/h (0 -155 mph)	
PTO_OUT3_ENGINE_MIN_SPEED	IGG	500 RPM	500-700 RPM	
PTO_OUT4_ON_EDGE	ZL	1	0/1	
PTO_OUT4_PARK_BRAKE	ZM	0	0/1	
PTO_OUT4_NEUTRAL_GEAR	ZN	0	0/1	
PTO_OUT4_LOWSPLIT_GEAR	ZO	0	0/1	
PTO_OUT4_ENGINE_SPEED_LOW	ZP	500 RPM	500-700 RPM	
PTO_OUT4_ENGINE_SPEED_HIGH	ZQ	2500 RPM	700-2500 RPM	

Parameter Name	Code	Default Value	Range	Description
PTO_OUT4_VEHICLE_SPEED	ZR	250 km/h (155 mph)	2-250 km/h (1-155 mph)	
PTO_OUT4_TYPE	ZS	2 Trans 2	0, 1, 2, 3, 4	
PTO_OUT4_ENG_LIM	ZT	0	0/1	
PTO_OUT4_MAX_ROAD_SPEED	EAT	250 km/h (155 mph)	0-250 km/h (0 -155 mph)	
PTO_OUT4_ENGINE_MIN_SPEED	IGH	500 RPM	500-700 RPM	

Descriptions of the PTO Output Parameters

Note: "x" represents the values 2-4.

Parameter Name	Description
PTO_OUTx_ON_EDGE	Specifies whether EDGE triggering will be used for the Input / Enable input pins. 0 = Level, 1 = Edge. Further information below.
PTO_OUTx_PARK_BRAKE	Specifies whether the Park Brake must be set before the PTO Output can engage. 0 = No, 1 = Yes. If "Yes", releasing the Park Brake will either prevent engagement, or it will disengage the PTO if already operating. Also see EDGE vs. LEVEL triggering, below.
PTO_OUTx_NEUTRAL_GEAR	Specifies whether the transmission must be in Neutral before the PTO Output can engage. 0 = No, 1 = Yes. If "Yes", taking the transmission out of Neutral will either prevent engagement, or it will disengage the PTO if already operating. Also see EDGE vs. LEVEL triggering, below. NOTE that the BBM's Neutral Gear Input must be used to tell the BBM the state of the transmission; no wire connected to that input will act as though the transmission is never in Neutral.
PTO_OUTx_LOWSPLIT_GEAR	Specifies whether the transmission must be in a Low Split gear before the PTO Output can engage. 0 = No, 1 = Yes. If "Yes", taking the transmission out of a Low Split gear will either prevent engagement, or will disengage the PTO if it was operating. Also see EDGE vs. LEVEL triggering, below. NOTE that the BBM's Low Split Gear Input must be used to tell the BBM the state of the transmission; no wire connected to that input will act as though the transmission is never in a Low Split gear.
PTO_OUTx_ENGINE_SPEED_LOW	The engine speed must be above this value for at least two seconds before the PTO Output will engage for the first time.
PTO_OUTx_ENGINE_SPEED_HIGH	This parameter has two functions: As an entry condition: The engine speed must be below this value before the PTO Output will engage for the first time. As a limit condition: If the PTO_OUTx_ENG_LIM (see below) parameter is set, this becomes the engine speed limit while the PTO Output #x is engaged.
PTO_OUTx_VEHICLE_SPEED	The vehicle speed must be below this value before the PTO Output will engage for the first time. Once engaged, the PTO will disengage if vehicle speed exceeds this limit. Also see EDGE vs. LEVEL triggering, below.
PTO_OUTx_TYPE	Specifies where the PTO device is located (engine or trans.). Only needed when a Volvo-brand transmission is installed; any other transmission can accept any value (1 ~ 4) in this parameter with the same results.
PTO_OUTx_ENG_LIM	Used in combination with PTO_OUTx_ENGINE_SPEED_HIGH. If this parameter is set, then the Engine Speed limitation will be treated as an Engine Speed limit while the PTO is engaged (not just as an entry condition).

Body Builder CAN (J1939) Interface

A dedicated J1939 datalink is available for body builder use. This link is physically isolated from the "main" J1939 datalink present in the vehicle, and in addition will only allow certain messages from the body builder to be transferred to the main J1939 datalink. This could be used by body builders who are interested in receiving databus information from the vehicle, or who are interested in making direct engine speed / torque commands to the powertrain.

Pin/Connector Information

Pin Name	I/O, Type	BBM ECU Pin No.	ELCE-CK Connector Pin
Body Builder J1939-A (high)	J1939 databus	A15	N/A
Body Builder J1939-B (low)	J1939 databus	A16	N/A

Note: These circuits are not routed to the ELCE-CK Body Builder connector. Terminals need to be added to the BBM ECU connector (A) if this function is desired.

Note: Any wiring added to the pins must conform to the SAE J1939-15 or J1939-11 recommended practices.

Pre-requisites/Conditions for Activation

One (or more) parameters enabled to indicate whether the Body Builder wants the ability to "listen" only, or "talk" on the vehicle's J1939 databus.

Related BBM ECU Parameters/Setup for Premium Tech Tool 2 (VEUC 4)

Parameter Name	Code	Default Value	Range	Description
BB_BUS_LISTEN	AET	0	0/1	Passes specific databus messages (see below) from Vehicle's J1939 databus to the Body Builder J1939 Bus (allows the Body Builder to LISTEN)
F_VWGATEWAY_ENABLE	DVQ	0	0/1	
NEUTRAL_GATEWAY_DEBOUNCE_TIME	IHD	0 seconds	0 – 5 seconds	
F_TCO1GATEWAY_ENABLE	DVO	0	0/1	
F_TDGateway_ENABLE	DVU	0	0/1	
F_HRVDGateway_ENABLE	DVT	0	0/1	
F_AMBGATEWAY_ENABLE	NWP	0	0/1	
F_AIR1GATEWAY_ENABLE	NWQ	0	0/1	

Other Information/Notes

BB_BUS_LISTEN

When parameter BB_BUS_LISTEN is enabled, this copies the following J1939 messages from the vehicle's main J1939 bus, and re-transmits them on the Body Builder J1939 bus for external use:

- ETC1 (from transmission)
- ETC2 (from transmission)
- CCVS (from VECU)
- EEC1 (from engine)
- EEC2 (from engine)

When setup for listening only, messages placed onto the Body Builder J1939 databus by the body builder will not be passed onto the vehicle's main J1939 databus.

BB_BUS_CONTROL

When parameter BB_BUS_CONTROL is enabled, this allows the body builder to issue direct torque and speed commands to the engine using the J1939 TSC1 message, within limits:

- Speed control requests from the body builder - will be translated into a message that appears to originate from the BBM ECU, to avoid conflict with other ECUs on the link. Certain 'sanity checks' will also be made on the request before passing it on to the engine.
- All other requests from the body builder - including speed and torque limits - will be placed directly onto the vehicle's main J1939 datalink, using the body builder's source address.

While parameter BB_BUS_CONTROL is enabled, certain functions within the BBM ECU are disabled since it is assumed that the body builder wishes to have a higher priority. Internal BBM functions which are disabled include:

- PTO Engine Speed Control Input(s)
- Engine Speed Limit Input
- Engine Torque Limit Input
- Forced Idle / Throttle Interlock Input

Notes

BBM Connector A (Orange 30-way)

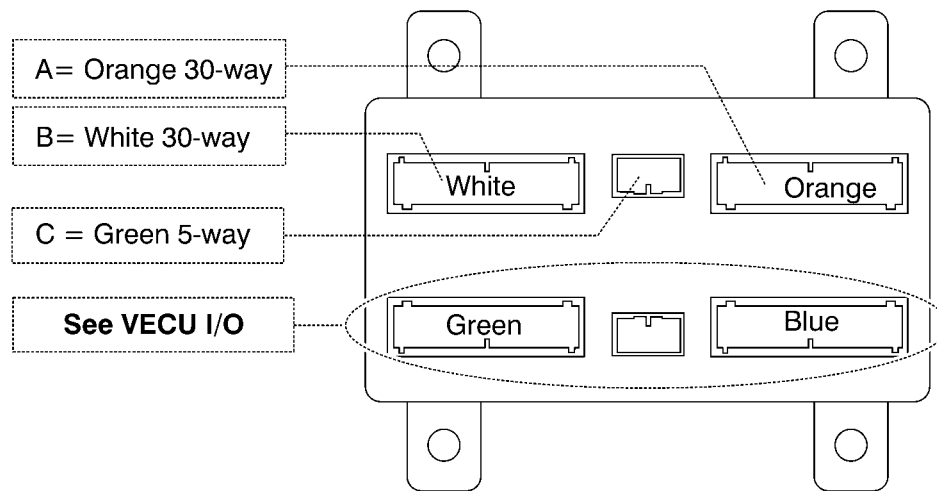

W3007653

Pin	Pin Name/Description	I/O	Type	Comment
A1	Remote PTO Spd DEC	Input	Active High	
A2	Remote PTO Spd INC	Input	Active High	
A3	PTO Mode 3	Input	Active High	
A4	PTO Mode 1	Input	Active High	
A5	PTO Mode 4	Input	Active High	
A6	Engine Shutdown, N.O. Sw	Input	NO Switch to +V	Always enabled in software; closing switch causes engine shutdown
A7	Forced Idle	Input	Active High	
A8	N/A	Input	Active High	Do not connect; manufacturing use only
A9	N/A	Input	Active High	Do not connect; manufacturing use only
A10	N/A	Input	Active High	Do not connect; manufacturing use only
A11	N/A			
A12	ECU Ground	ECU Main Power Ground		
A13	ECU Main Power	Input	ECU Main Power	
A14	Spare	Input	Active High	
A15	CAN4-High (Body Builder)	Bidirectional Databus		J1939 Databus for use by body builder only (limited to certain parameters / authority)
A16	CAN4-Low (Body Builder)			
A17	Engine Speed Limit	Input	Active High	
A18	PTO2 Input/Dash Sw	Input	Active High	
A19	PTO3 Input/Dash Sw	Input	Active High	
A20	PTO4 Input/HSA Dash Sw	Input	Active High	

Pin	Pin Name/Description	I/O	Type	Comment
A21	N/A	Input	Active High	Do not connect; manufacturing use only
A22	N/A	Input	Active High	
A23	Spare	Input	Active High	
A24	Neutral Gear Input	Input	Active High	(Note 1)
A25	Engine Torque Limit 1	Input	Active Low	
A26	Road Speed Limit	Input	Active Low	
A27	Engine Shutdown, N.C. Sw	Input	NC Switch to Ground	Must be enabled in software; Opening switch causes engine shutdown
A28	Low Split Input	Input	Active Low	(Note 1)
A29	Split Box Input	Input	Active High	(Note 2)
A30	Spare	Input	Active High	

- 1 NEUTRAL GEAR and LOW SPLIT inputs are used as programmable lock-outs for PTO engagement. If a corresponding databus message is available (J1939 ETC2 from trans.), the databus message will have priority over the input pin.
- 2 SPLIT BOX input is usable for split-shaft PTOs; it allows a temporary override of the normal road speed limit, so long as the park brake is set. Without this input, engine speed / power may be limited because the ECU thinks the vehicle is moving when it sees transmission output shaft activity.

Notes

BBM Connector B (White 30-way)

Pin	Pin Name/Description	I/O	Type	Comment
B1	Engine Remote Start Enable	Output	Active Low	
B2	PTO 2 Output	Output	Active Low	
B3	PTO 3 Output	Output	Active Low	
B4	PTO 4 Output/HSA Output	Output	Active Low	
B5	I-Shift Dual PTO Switch	Output	Switch Power	Use for BBM-connected switches ONLY
B6	N/A			
B7	Spare	Input	Active High	
B8	Spare	Input	Analog	
B9	2nd Accelerator Sensor	Input	Analog Sensor	1K Ω minimum total sensor value
B10	Output Supply #1 (~5V)	Output	Sensor Power	Use for BBM-connected sensors ONLY
B11	Spare	Input	Active Low	
B12	2nd Accelerator Pedal Enable	Input	Active Low	Enables 2nd Accelerator Pedal or Remote Throttle
B13	Spare	Input	Active Low	
B14	Spare	Input	Analog	
B15	No connect			
B16	Warning Output	Output	Active Low	
B17	No connect			
B18	Databus Triggered Output	Output	Active Low	
B19	Output Supply #3 (~V _{batt})	Output	Switch Power	Use for BBM-connected switches ONLY
B20	No connect			
B21	PTO Mode 2	Input	Active High	
B22	Analog Ground	ECU Sensor Ground		Use for BBM-connected sensors ONLY
B23	Analog Ground	ECU Sensor Ground		Use for BBM-connected sensors ONLY
B24	Spare	Input	Analog	
B25	Output Supply #5 (6.5~9V)	Output	Powered VSS	Use for BBM-connected sensors ONLY
B26	Output Supply #2 (~5V)	Output	Sensor Power	Use for BBM-connected sensors ONLY
B27	Spare	Input	Analog	
B28	Speed Output	Output	Active High	
B29	Spare	Input	Active Low	
B30	2nd Accelerator Pedal IVS	Input	Active High	

BBM Connector C (Green 5-way)

Pin	Pin Name/Description	I/O	Type	Comment
C1	J1587 / B (SAE J1708 (B))	Bidirectional	Databus	J1708/J1587 (slow speed) Databus
C2	J1587 / A (SAE J1708 (A))			
C3	No Connect			
C4	J1939 / A (CAN_H)	Bidirectional	Databus	J1939 (high speed) Databus
C5	J1939 / B (CAN_L)			

Summary of Adjustable VECU/BBM Parameters

The following pages contain lists of the Customer-changeable parameter settings for the VECU and BBM ECU. For each ECU, there are two lists:

- "Vehicle" parameters; these are field-changeable using VCADS-Pro with a network connection. The network connection is so a central record of the changes can be maintained by Volvo Trucks North America.
- "Customer" parameters; these are field-changeable using VCADS without a network connection.

For each parameter, the following information is supplied:

Parameter Name - note that the name given here is intended to be the name which is presented in VCADS-Pro, and may be different from the internal parameter name. In case of any questions, always use the parameter code.

Parameter Code

Applicability - whether applies to Volvo engine only, Cummins engine only, or both.

Default Value

Adjustment Range - if the range depends on the value of another parameter, the range will be given as a series of parameter codes, instead of a numeric range.

Description of parameter - for parameters which are fully described elsewhere in this document, the only description given here will be a reference to the appropriate section elsewhere.

Notes

Parameter Descriptions/Settings

VECU-Vehicle Parameters

Parameter Name	Code	App	Default Value	Adjustment Range	Description
Calibration Number US ("k-factor")	MH	B	16667 pulse/km	3000-25000 pulses/km	Speed sensor calibration; tells the number of pulses per kilometer from the transmission output shaft. Derived from Output Shaft cogs, axle gear ratio, and tire revolutions per km.
Cummins retarder switch pos1	ATC	C	17%	0-100 %	Used for Cummins engines only; tells the VECU what percent of engine braking to request from the ECM for the various dash switch and retarder lever positions. See "ENGINE BRAKE CONTROL SETUPS" in the VECU section.
Cummins retarder switch pos1	ATD	C	33%	0-100 %	
Cummins retarder switch pos1	ATE	C	50%	0-100 %	
Cummins retarder switch pos1	ATF	C	67%	0-100 %	
Cummins retarder switch pos1	ATG	C	83%	0-100 %	
Cummins retarder switch pos1	ATH	C	100%	0-100 %	
AirConditioning Installed	CX	B	1	0/1	Tells the VECU whether or not to pass on A/C Pressure Switch fan request information to the ECM.

VECU-Customer Parameters

Parameter Name	Code	App	Default Value	Adjustment Range	Description
Automatic Idle Speed Shutdown	AL	V	0	0/1	Enables / Disables the Idle Shutdown function. (1 = Enabled)
Max Idle Speed Time	AM	V	300 Seconds	60-18000 Seconds	Defines the Idle Shutdown Timer duration.
ENGLOAD_IN_PTO_FOR_ISD	CMM	V	20%	0 ~ 100%	Actual engine loads above this value will prevent Idle Shutdown from occurring while in PTO / High Idle mode 0% = never shutdown in PTO, 100% = always shutdown in PTO
ALLOW_PERM_ISD_OVERRIDE	CMQ	V	0	0/1	Allow for unattended override during the 'driver alert' period.
MIN_AMBIENT_FOR_ISD	CMN	V	-17° C (0°F)	-40 -15 C (-40 - 60 ° F)	Ambient temperatures below this value will prevent shutdown.
MAX_AMBIENT_FOR_ISD	CMO	V	49° C (120 °F)	21-66 ° C (70 - 150 °F)	Ambient temperatures above this value will prevent shutdown.
IGNORE_PARKBRAKE_FOR_ISD	CML	V	0	0/1	Yes (1) = will shutdown regardless of Park brake status; No (0) = will not shutdown unless Park brake is engaged

Parameter Name	Code	App	Default Value	Adjustment Range	Description
MAX_ENGTEMP_FOR_ISD	CMP	V	93° C (200 °F)	82 - 124° C (180 - 255 °F)	Engine coolant temp. above this value will prevent shutdown.
VEHICLE_SPEED_FACTOR_TWO	AZL	B	16667 pulses/km	3000-25000 pulses/km	When a Two-Speed axle is enabled with parameter AZM, this "k-factor" is used in place of the primary "k-factor" to account for the new effective axle ratio.
ENABLE_SECOND_SPEED_AXLE	AZM	B	0	0/1	Tells the VECU whether or not to use input PA-25 (active LOW) as a 2-speed axle input for vehicle speed correction.

PTO-Related Parameters

Parameter Name	Code	App	Default Value	Adjustment Range	Description
HIGH_IDLE_DEFAULT_RE_ESPD	ANE	V	750	Must be within a window defined by parameters ANF-AND	Default RESUME Engine Speed for "Stalk PTO" (high idle)
HIGH_IDLE_MIN_ESPD	ANF	V	500 RPM	500-2500 RPM	Minimum allowed engine speed while in "Stalk PTO"; "ANF" must be < "AND"
HIGH_IDLE_MAX_ESPD	AND	V	2500 RPM	500-2500 RPM	Maximum allowed engine speed while in "Stalk PTO"; "AND" must be > "ANF"
PTO_HIGH_IDLE_BRAKE_COND	XP	V	1	0/1	Specifies whether the service brake pedal must be released in order to maintain PTO engine speed control ("high idle"). 0 = No / 1 = Yes
PTO_HIGH_IDLE_PARKINGBRAKE_CONDITION	AZG	V	0	0/1	Specifies whether the Park brake must be set in order to maintain PTO engine speed control ("high idle"). 0 = No / 1 = Yes
PTO_ENABLE_HIGHIDLE_WITH_PTO_ENABLE_SW	AZH	V	0	0/1	Specifies whether PTO Engine Speed control mode (aka "stalk PTO" or "high idle" mode) will be initiated when the PTO1 Input / Enable pin is activated. (0 = No / 1 = Yes)
PTO_STEP_FACTOR	RT	V	50 RPM	1-250 RPM	Each short press of the CC Set(+) or Set(-) buttons will trim the set speed by this amount
PTO_MAX_VSPD	DA	V	12 km/h (7.5 mph)	0-30 km/h (0-19 mph)	PTO Engine Speed Control mode will drop out if Vehicle Speed exceeds this value
PTO_OUTPUT_PARKINGBRAKE_CONDITION	XM	V	1	0/1	Specifies whether or not the Park brake must be applied before the VECU's PTO Output will become active (0 = No, 1 = Yes)

Parameter Name	Code	App	Default Value	Adjustment Range	Description
PTO_OUTPUT_TYPE	XN	V	3 (ENG)	1-4	See description for BBM PTO Output Control
PTO_SET_OUTPUT	XO	V	1	0/1	Specifies whether or not the VECU's PTO Output driver should be driven when the PTO1 Input is activated. (0 = No, 1 = Yes)
PTO_BASIC_MODE_ENABLE	QP	V	1	0/1	Specifies whether or not the VECU will use the PA-29 PTO Enable Input. (Currently does not affect High-Ide function)

VECU-Customer Parameters (Cont.)

Cruise Control Related Parameters

Parameter Name	Code	App	Default Value	Adjustment Range	Description
F_ENABLE_CRUISE_CONTROL	AG	V	1	0/1	Specifies whether or not the Cruise Control function is enabled.
Cruise Control Max Set Speed	AI	V	130 km/h (81 mph)	30-140 km/h (19-87 mph) must be BK	Specifies the maximum vehicle speed which will be allowed while operating in Cruise Control mode. Note that this is not vehicle maximum speed limit, though it could be set to the same value.
Cruise Control Min Set Speed	BK	V	30 km/h (19 mph)	30-140 km/h (19-87 mph); must be <AI	Specifies the lowest vehicle speed, below which setting of cruise control will not be allowed.
Cruise Control Min Governed Speed	BL	V	15 km/h (9 mph)	15-30 km/h (9-19 mph)	
Cruise Trim Factor	GP	V	2 km/h/s (1 mph/s)	0-10 km/h/s (0-6 mph/s)	Specifies the speed change ramp that will be requested (in km/h per Second) when the CC Set(+) button is 'held'.
CRUISE_TRIM_FACTOR_MINUS	RR	V	2 km/h/s (1 mph/s)	0-10 km/h/s (0-6 mph/s)	Specifies the speed change ramp that will be requested (in km/h per Second) when the CC Set(-) button is 'held'.
CRUISE_STEP_FACTOR	RS	V	2 km/h/s (1 mph/s)	0-10 km/h/s (0-6 mph/s)	Specifies the speed change that will be requested for each 'tap' of the CC Set(+) or Set(-) button.

BBM ECU-Vehicle Parameters

Note: All BBM Parameters apply to Volvo Engine Only.

There are no "Vehicle" parameters for the BBM. All field-accessible parameters are customer-parameters and can be adjusted by VCADS-Pro without the need for a network connection.

BBM ECU-Customer Parameters

Note: All BBM Parameters apply to Volvo Engine Only.

Non-PTO, General Parameters

Parameter Name	Code	Description	
Engine Speed Enable	GU	See "Engine Speed Limit Input", page 91 in BBM ECU / ELCE-CK SECTION	
Engine Speed Limit Value	GQ		
Engine Torque Limit 1 Enable	GW	See "Engine Torque Limit Input", page 92 in BBM ECU / ELCE-CK SECTION	
Engine Torque Limit Value 1	GR		
F_ENABLE_RSL	GV	See "Road Speed Limit Input", page 93 in BBM ECU / ELCE-CK SECTION	
Road Speed Limit Optional Vehicle Speed Set	IG		
Reverse Inhibit	AIA		
Second Accelerator Pedal Enable	EE		
RSL Accelerator Pedal Condition	GO		
Enable RSL Accelerator Pedal Exit Condition	FNO		
RSL Accelerator Pedal Value Position	FNP		
Temporary RSL Enable	IFW		
Enable RSL3 for BBM	LIN		
Limit Value for RSL3	CEC		
Enable Lowest Gear as Starting Position	IZV		
F_ENABLE_SHUT DOWN	IL		See "Engine Shutdown Inputs", page 88 in BBM ECU / ELCE-CK SECTION
Trig Output above Engine Speed (0=off)	ADA		See "Databus Triggered Output", page 110 in BBM ECU / ELCE-CK SECTION
Trig Output above Output Shaft Speed (0=off)	ADB		
Trig Output above Vehicle Speed (0=off)	ADC		
Gear in Neutral	AHZ		
ENGINE_SPEED_HYSTERESIS	PDN		
VEHICLE_SPEED_HYSTERESIS	PDP		
OUTPUT_SHAFT_SPEED_HYSTERESIS	PDO		
Body Builder bus., Listen Enable	AET	See "Body Builder CAN (J1939) Interface", page 124 in BBM ECU / ELCE-CK SECTION	
Body Builder bus.,	AEU		

Parameter Name	Code	Description
Control Enable		
Engine speed mode resume switch toggle	IFS	See "Resume to Pre-set Speed", page 90 in BBM ECU
Engine Oil Level Warning On (PID 98)	AEI	<p>See "System Warning Output", page 108 in BBM ECU / ELCE-CK SECTION</p> <p>Note: Transmission Oil Temp (PID 177) is usable only with Allison Transmission</p>
Engine Oil Pressure Warning On (PID 100)	AEJ	
Engine Crankcase Pressure Warning On (PID 153)	AEK	
Engine Coolant Temperature Warning On (PPID119)	AEL	
Engine Coolant Level Warning On (PID 111)	AEM	
Transmission Oil Temperature Warning On (PID 177)	AEN	
Engine Oil Temperature Warning On (PID 175)	AEP	
Transmission Oil Level Warning On (PID 124)	AEO	
C3 Output Enable	GT	
C3 Output (Vehicle Speed)	LV	
C3 Digital Invert	SD	
C3_RPM_FRQ_CONST	CZT	
Engine speed mode resume switch toggle	IFS	See "Resume to Pre-set Speed", page 90 in BBM ECU

Notes

Remote/2nd Throttle Parameters

Parameter Name	Code	Default Value	Adjustment Range	Description
Second Throttle	EE	0	0/1	See "Remote Throttle/2nd Accelerator Pedal", page 101 in BBM ECU / ELCE-CK SECTION.
Dual Drive (SECOND_PEDAL_RSL)	GO	20 km/h	20-140 km/h	
Enable Hand Throttle	ZX	0	0/1	
Hand Throttle Low Limit	ZY	200 (0.98 V)	Must be < ZZ and ≥ AER	Hand throttle, lower limit. This parameter sets the corresponding analogue value from the hand throttle potentiometer to the upper limit value 0%.
Hand Throttle High Limit	ZZ	900 (4.40 V)	Must be > ZY and ≤ AES	Hand throttle, upper limit. This parameter sets the corresponding analogue value from the hand throttle potentiometer to the upper limit value 100%.
Handthrottle Range, Minimum Limit	AER	100 (0.49 V)	Must be ≤ ZY and ≤ AES	Defines the low and high diagnostic limits for the Remote / 2nd Throttle input. Readings below (or above) these readings will set a fault code.
Handthrottle Range, Maximum Limit	AES	1000 (4.89 V)	Must be ≥ ZZ > AER	
Enable Extra Gear Lever	AIB	0 (OFF)	0/1	Enable extra gear lever. This parameter governs the condition for extra gear lever functionality.

NOTE for the Hand Throttle A/D Counts to Voltage conversion:

Each A/D count represents 0.00489 Volt (or 4.89 mVolt). To determine the A/D counts knowing the desired voltage, multiply the voltage by 204.8: Example: what A/D counts = 1.5 Volts? $A/D = (204.8) * (\text{Voltage}) = (204.8) * (1.50) = 307$ A/D counts (round to the nearest whole number).

Notes

BBM-Customer Parameters (Cont.)

General PTO Parameters (Not Specific to One Mode)

Parameter Name	Code	Default Value	Adjustment Range	Description
PTO_MIN_ENGINE_SPEED	DC	500 RPM	500 ~ 2500 RPM (must be < AA)	Minimum engine speed that will be allowed while in PTO mode, while using the BBM ECU's PTO "DEC" input. (Also see params AND, ANF for VECU).
PTO_MAX_ENGINE_SPEED	AA	2500 RPM	500 ~ 2500 RPM (must be > DC)	Maximum engine speed that will be allowed while in PTO mode, while using the BBM ECU's PTO "INC" input. (Also see params AND, ANF for VECU).
PTO Trim Factor	IF	50 RPM per second	0-250	PTO Engine speed change ramp (in RPM per second) that will result when the BBM's PTO INC or DEC inputs are continuously activated ("held"). See "PTO Engine Speed Increment/Decrement Inputs", page 119 in BBM ECU SECTION. A separate parameter in the VECU is used for when CC Set+/- buttons are used for adjustment.
ENABLE_SPLITBOX_INPUT	BRQ	0	0/1	See "Split Shaft (Split Box) PTO Input", page 98 in BBM ECU / ELCE-CK SECTION.
F_PARK_ENABLE	LJL	1	0/1	
F_SPEED_ENABLE	LJM	1	0/1	
PTO_OUTX_LEGAL_RSL	9D	300 (raw value) Equivalent to 30.000000447-0348 kmph	30.0000004470348 kmph To 140.000002086163 kmph	Road speed limit, mandated by law.
ENGINE_SPEED_MODE_RESUME_SWITCH_TOGGLING	IFS	0	0/1	REFER TO "PTO Engine Speed Control Inputs", page 113 in BBM ECU / ELCE-CK SECTION OF THIS DOCUMENT FOR DETAILS ON DEFAULT VALUES, ADJUSTMENT RANGES, AND DESCRIPTIONS.
BB_ENGINESPD_CONTROL	DWC	0	0/1	
ESM_MODE_ENTRY_RAMP	IHV	0	0 - 250 rpm/s	
ESM_MODE_EXIT_RAMP	IHW	0	0 - 250 rpm/s	
F_ENABLE_ESC_BBCAN_BRAKE_SWITCH	NWT	1	0/1	

PTO #1 Parameters

Parameter Name	Code	Default Value	Adjustment Range	Description
PTO 1 Enable	IC	1	0/1	Turns off/on the PTO 1 Engine Speed Control function within the BBM.
PTO 1 Engine Resume Speed	HB	800 RPM	500 - 2500	REFER TO "PTO Engine Speed Control Inputs", page 113 in BBM ECU / ELCE-CK SECTION OF THIS DOCUMENT FOR DETAILS ON DEFAULT VALUES, ADJUSTMENT RANGES, AND DESCRIPTIONS.
PTO 1 Idle Return Delay	HE	0	0 - 10 Second	
PTO 1 Disengagement Condition Brake Pedal	BRR	0	0/1	
PTO 1 disengagement condition clutch pedal	BRV	0	0/1	
PTO 1 disengagement condition Park Brake	HH	1	0/1	
PTO 1 Disengagement Condition PTO Enable Switch	HT	0	0/1	
EMS_MODE_ENTRY_RAMP	IHV	0	0 - 250 RPM per second	
EMS_MODE_EXIT_RAMP	IHW	0	0 - 250 RPM per second	
PTO 1 Edge Trig	YJ	1	0/1	

BBM-Customer Parameters (Cont.)

PTO #2 Parameters

Parameter Name	Code	Default Value	Adjustment Range	Description
PTO 2 Enable	ID	1	0/1	Turns off/on the PTO 2 Engine Speed Control function within the BBM.
PTO 2 Engine Resume Speed	HC	1000 RPM	500 - 2500	REFER TO "PTO Engine Speed Control Inputs", page 113 in BBM ECU / ELCE-CK SECTION OF THIS DOCUMENT FOR DETAILS ON DEFAULT VALUES, ADJUSTMENT RANGES, AND DESCRIPTIONS.
PTO 2 Idle Return Delay	HF	0	0 - 10 Seconds	
PTO 2 Disengagement Condition Brake Pedal	BRS	0	0/1	
PTO 2 disengagement condition clutch pedal	BRW	0	0/1	
PTO 2 disengagement condition Park Brake	HI	1	0/1	
EMS_MODE_ENTRY_RAMP	IHV	0	0 - 250 RPM per second	
EMS_MODE_EXIT_RAMP	IHW	0	0 - 250 RPM per second	

Parameter Name	Code	Default Value	Adjustment Range	Description
PTO 2 Disengagement Condition PTO Enable Switch	HU	0	0/1	
PTO 2 Edge Trig	YK	1	0/1	
PTO 2 Road Speed Limit	EAR	161 KMPH (100 mph)	5 - 255 KMPH (3 - 158 mph)	
PTO 2 Engine Minimum Speed	IGF	500 RPM	500 - 1500 RPM	
PTO 2 Engine Speed Increasing Ramp	IHP	0	0 - 250 rpm/s	
PTO 2 Engine Speed Decreasing Ramp	IHS	0	0 - 250 rpm/s	
PTO Out 2 Engage Condition Edge Trig	YT	1	0/1	REFER TO "PTO Output Control (Inputs and Outputs)", page 120 in BBM ECU / ELCE-CK SECTION OF THIS DOCUMENT FOR DETAILS ON DEFAULT VALUES, ADJUSTMENT RANGES, AND DESCRIPTIONS.
PTO Out 2 Engage/On Condition Parking Brake	YU	0	0/1	
PTO Out 2 Engage/On Condition Gear in Neutral	YV	0	0/1	
PTO Out 2 Engage/On Condition Gear in Low Split	YW	0	0/1	
PTO Out 2 Engage/On Condition Engine Speed Above	YX	500 RPM	300 - 700	
PTO Out 2 Engage Condition Engine Speed Below	YY	2500 RPM	700 - 2500	
PTO Out 2 Mount	ZA	4	0 - 4	
PTO Out 2 Limit Engine Speed On Active	ZB	0	0/1	
PTO Out 2 Engage/On Condition Vehicle Speed Below	YZ	90 km/h (56 mph)	2 - 130 km/h (1- 81 mph)	

PTO #3 Parameters

Parameter Name	Code	Default Value	Adjustment Range	Description
PTO 3 Enable	IE	1	0/1	Turns off/on the PTO 3 Engine Speed Control function within the BBM
PTO 3 Engine Resume Speed	HD	1200 RPM	500 - 2500	REFER TO "PTO Engine Speed Control Inputs", page 113 in BBM ECU / ELCE-CK SECTION OF THIS DOCUMENT FOR DETAILS ON DEFAULT VALUES, ADJUSTMENT RANGES, AND DESCRIPTIONS.
PTO 2 Idle Return Delay	HG	0	0 - 10 Seconds	
PTO 2 Disengagement Condition Brake Pedal	BRT	0	0/1	
PTO 3 disengagement condition clutch pedal	BRX	0	0/1	
PTO 3 disengagement condition Park Brake	HJ	1	0/1	
EMS_MODE_ENTRY_RAMP	IHV	0	0 - 250 RPM per second	
EMS_MODE_EXIT_RAMP	IHW	0	0 - 250 RPM per second	
PTO 3 Disengagement Condition PTO Enable Switch	HV	0	0/1	
PTO 3 Edge Trig	YL	1	0/1	
PTO 3 Road Speed Limit	EAS	161 KMPH (100 mph)	5 - 255 KMPH (3 - 158 mph)	
PTO 3 Engine Minimum Speed	IGG	500 RPM	500 - 1500 RPM	
PTO 3 Engine Speed Increasing Ramp	IHQ	0	0 - 250 rpm/s	
PTO 3 Engine Speed Decreasing Ramp	IHU	0	0 - 250 rpm/s	
PTO Out 3 Engage Condition Edge Trig	ZC	1	0/1	REFER TO "PTO Output Control (Inputs and Outputs)", page 120 in BBM ECU / ELCE-CK SECTION OF THIS DOCUMENT FOR DETAILS ON DEFAULT VALUES, ADJUSTMENT RANGES, AND DESCRIPTIONS.
PTO Out 3 Engage/On Condition Parking Brake	ZD	0	0/1	
PTO Out 3 Engage/On Condition Gear in Neutral	ZE	0	0/1	
PTO Out 3 Engage/On Condition Gear in Low Split	ZF	0	0/1	
PTO Out 3 Engage/On Condition Engine Speed Above	ZG	500 RPM	300 - 700	
PTO Out 3 Engage Condition Engine Speed Below	ZH	2500 RPM	700 - 2500	

Parameter Name	Code	Default Value	Adjustment Range	Description
PTO Out 3 Mount	ZJ	1	0 - 4	
PTO Out 3 Limit Engine Speed On Active	ZK	0	0/1	
PTO Out 3 Engage/On Condition Vehicle Speed Below	ZI	90 km/h (56 mph)	2 - 130 km/h (1- 81 mph)	

PTO #4 Parameters

Parameter Name	Code	Default Value	Adjustment Range	Description
PTO 4 Enable	YO	1	0/1	Turns off/on the PTO 4 Engine Speed Control function within the BBM.
PTO 4 Edge Trig	YM	1	0/1	REFER TO "PTO Engine Speed Control Inputs", page 113 in BBM ECU / ELCE-CK SECTION OF THIS DOCUMENT FOR DETAILS ON DEFAULT VALUES, ADJUSTMENT RANGES, AND DESCRIPTIONS.
PTO 4 Engine Resume Speed	YN	1400 RPM	500 - 2500	
PTO 4 Disengagement Condition PTO Enable Switch	YP	0	0/1	
PTO 4 disengagement condition brake pedal	BRU	0	0/1	
PTO 4 disengagement condition clutch pedal	BRY	0	0/1	
PTO 4 Disengagement Condition Parking Brake	YQ	1	0/1	
PTO 4 Idle Return Delay	YR	0	0 - 10 Seconds	
EMS_MODE_ENTRY_RAMP	IHV	0	0 - 250 RPM per second	
EMS_MODE_EXIT_RAMP	IHW	0	0 - 250 RPM per second	
PTO 4 Road Speed Limit	EAT	161 KMPH (100 mph)	5 - 255 KMPH (3 - 158 mph)	
PTO 4 Engine Minimum Speed	IGH	500 RPM	500 - 1500 RPM	
PTO 4 Engine Speed Increasing Ramp	IHR	0	0 - 250 rpm/s	
PTO 4 Engine Speed Decreasing Ramp	IHT	0	0 - 250 rpm/s	
PTO Out 4 Edge Trig	ZL	1	0/1	
PTO Out 4 Engage/On Condition Parking Brake	ZM	0	0/1	
PTO Out 4 Engage/On Condition Gear in Neutral	ZN	0	0/1	

Parameter Name	Code	Default Value	Adjustment Range	Description
PTO Out 4 Engage/On Condition Gear in Low Split	ZO	0	0/1	
PTO Out 4 Engage/On Condition Engine Speed Above	ZP	500 RPM	300 - 700	
PTO Out 4 Engage Condition Engine Speed Below	ZQ	2500 RPM	700 - 2500	
PTO Out 4 Mount	ZS	2	0 - 4	
PTO Out 4 Limit Engine Speed On Active	ZT	0	0/1	
PTO Out 4 Engage/On Condition Vehicle Speed Below	ZR	90 km/h (56 mph)	2 - 130 km/h (1- 81 mph)	

Notes

Supplemental Restraint System

Volvo vehicles may be equipped with a Supplemental Restraint System (SRS). The SRS is supplemental protection for use together with the safety belt. The SRS is designed to reduce the risk of injury to the driver's face and upper body.

The system consists of an inflatable bag mounted in the center of the steering wheel, and a control unit mounted on the bulkhead inside the cab. A chemical based gas generator attached to the rear of the bag inflates the bag in the event of a collision.

Sensors in the control unit detect deceleration. If the control unit detects a sufficiently violent deceleration (collision), the system is activated. The gas generator activates and fills the bag with a harmless gas within a few hundredths of a second. During a collision, after the bag has been filled, the gas flows out through two holes in the back of the bag. These holes are large enough to let the airbag collapse slowly, gently catching the driver.

The control unit also contains a standby power unit which can supply the system with power for a short time should the normal power supply be broken.

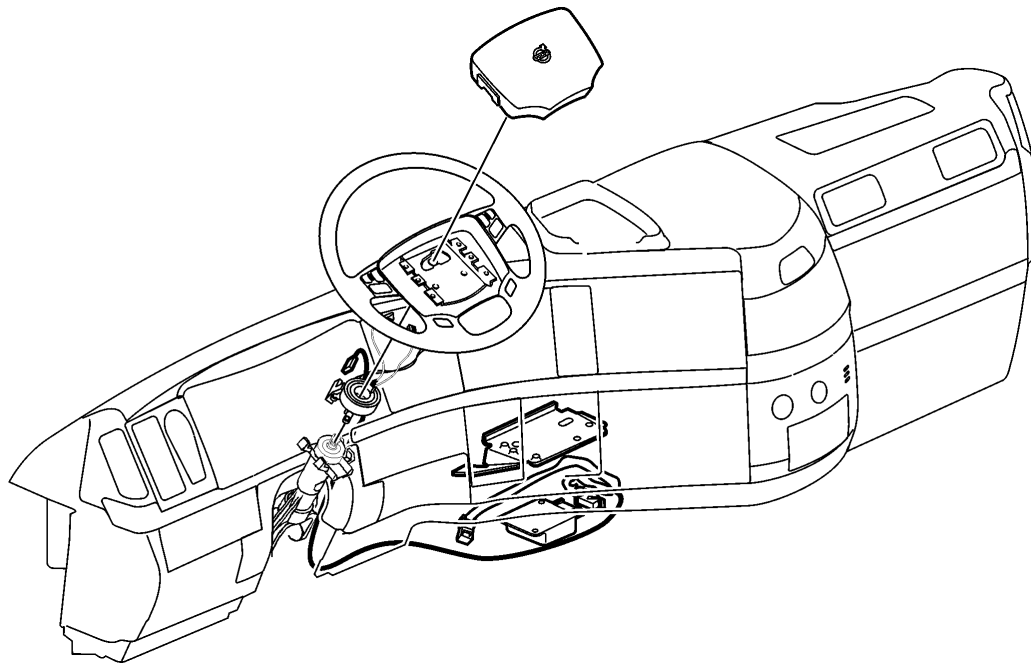

W8003216

Fig. 11 SRS System

Body Builder Module

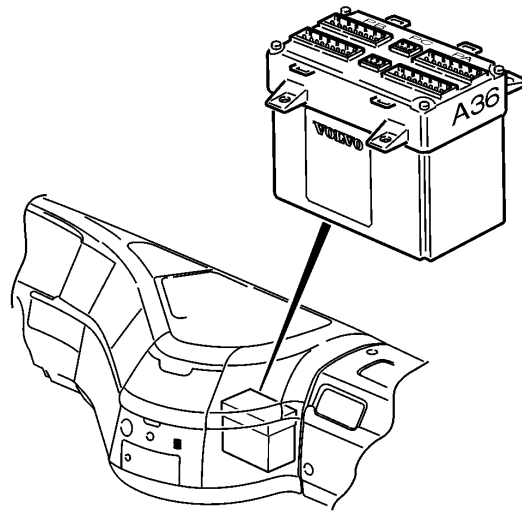

W3005434

The Body Builder Module (BBM) is an extension of the vehicle control unit (VECU) and is intended for superstructures, for example cement mixers, refuse trucks and mobile cranes. The body builder module is secured in a unit together with the vehicle control unit and is positioned under the dashboard.

Note: The BBM ECU is only available on VHD vehicles with a Volvo Engine.

Note: The BBM ECU is an optional ECU, installed only when variant ELCE-CK (Sales Code L3–C1) is chosen.

The BBM ECU must be installed whenever the vehicle will need more than one PTO Mode, or if the customer requires any of the following features:

- Switchable engine speed or torque limits
- Remote engine shutdown capability
- Forced Idle (throttle interlock) input
- Switchable road speed limit
- 2nd Accelerator Pedal or Remote Throttle controls
- Complex PTO programming, such as multiple PTO modes, interlocks, split shaft/split box PTOs, etc
- Remote control of the engine via J1939 control data link
- ECU generated outputs based on vehicle speed, system status, or other operating conditions

Note: If a “TwinFlow” side-engine PTO is factory-installed (variant PTES-T53, sales code T9–K1), a BBM ECU is not required. This is because the two flow rates of the PTO are achieved using only one PTO 'mode' or preset speed setting.

Climate Control (ECC/MCC)

Note: For basic operator information about the climate control system, refer to the Operator's Manual.



CAUTION

DO NOT interface to, modify, or alter any of the sensors or circuits used by the ECC / MCC systems. Refer to the A/C service manual for all service information.

Whenever the vehicle is equipped with air conditioning, either an Electronic Climate Control (ECC) or Manual Climate Control (MCC) ECU will be used to operate the front (dash) HVAC system. Both systems directly control the A/C compressor and HVAC blower, as well as offering diagnostic service codes which are readable using the instrument cluster.

Both systems receive information from other ECUs over the J1708 / J1587 databus, such as outdoor (ambient) temperature, vehicle speed, and engine operating conditions.

The ECC system includes a fully automatic mode of operation. The driver sets the desired temperature, and the system will automatically select the best mode (A/C, air outlet control, blower speed, etc.) to reach that temperature in the most comfortable way. An in-cab temperature sensor is located in the center dash panel, to the right of the ashtray. In addition to the automatic mode, full manual control of the HVAC system is possible.

The MCC system is fully manual (both blower speed and air outlet control). No in-cab temperature sensor is used.

Neither the ECC nor MCC systems has any interaction or control over the bunk HVAC system, which is controlled by the LECM (below).

Engine Electronics

All engines installed in Volvo trucks are electronically controlled. The Engine Control Modules (ECM) is relatively self-contained, except for receiving power and databus signals from the vehicle. The VECU supplies information on all in-cab controls, and supplies that information over the databuses (to both Volvo and Cummins engines).

There are some differences in the way that the Volvo and Cummins engines interact with the rest of the vehicle system, such as where certain functions are controlled. For example, with a Volvo engine, the Cruise Control function is divided between the ECM and the VECU. With a Cummins engine, the VECU does have a small part in that it supplies the CC switch information, but all Cruise Control governors and logic are contained within the ECM.

Certain features of the engines are programmable using a service tool. For Volvo engines, Premium Tech Tool 2 must be used to program these engine features. Information on adjustable parameters in the Volvo engine is included in the ECM programming section.

For Cummins engines, the Cummins INSITE tool is used. Refer to the appropriate Cummins literature for details.

Instrument Cluster

Note: For basic operator information about the instrument cluster, refer to the Operator's Manual.

The instrument cluster is used to provide the driver with information via gauges, indicator lamps and the Driver Info Display (DID).

There are three versions of the instrument cluster:

- Basic
- Mid
- High

Component location

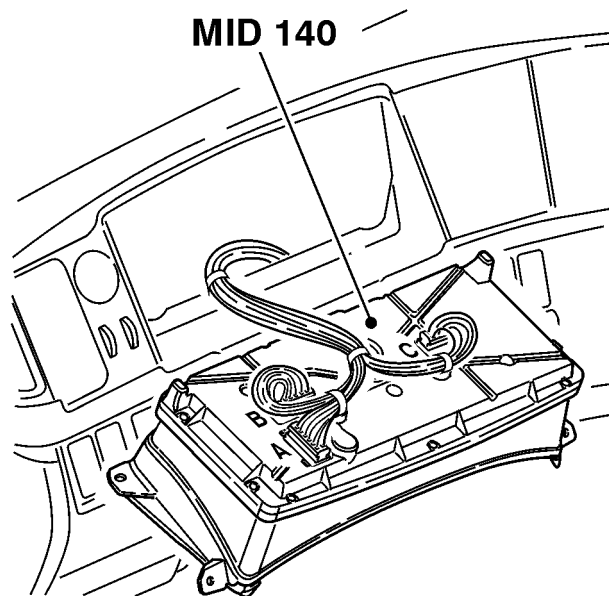

W3005144

MID 140 Instrument Cluster

- A** Connector A (22-pin)
- B** Connector B (30-pin)
- C** Connector C (30-pin)

Light Control Module

The Light Control Module (LCM) controls all exterior lighting functions separately from the interior lighting in the cab and optional extras installed on the vehicle. In addition, it controls the intermittent windshield wiper function and the windshield wiper function when the windshield washer is used. The control unit communicates with other systems via the J1587/1708 information link and the J1939 control data link.

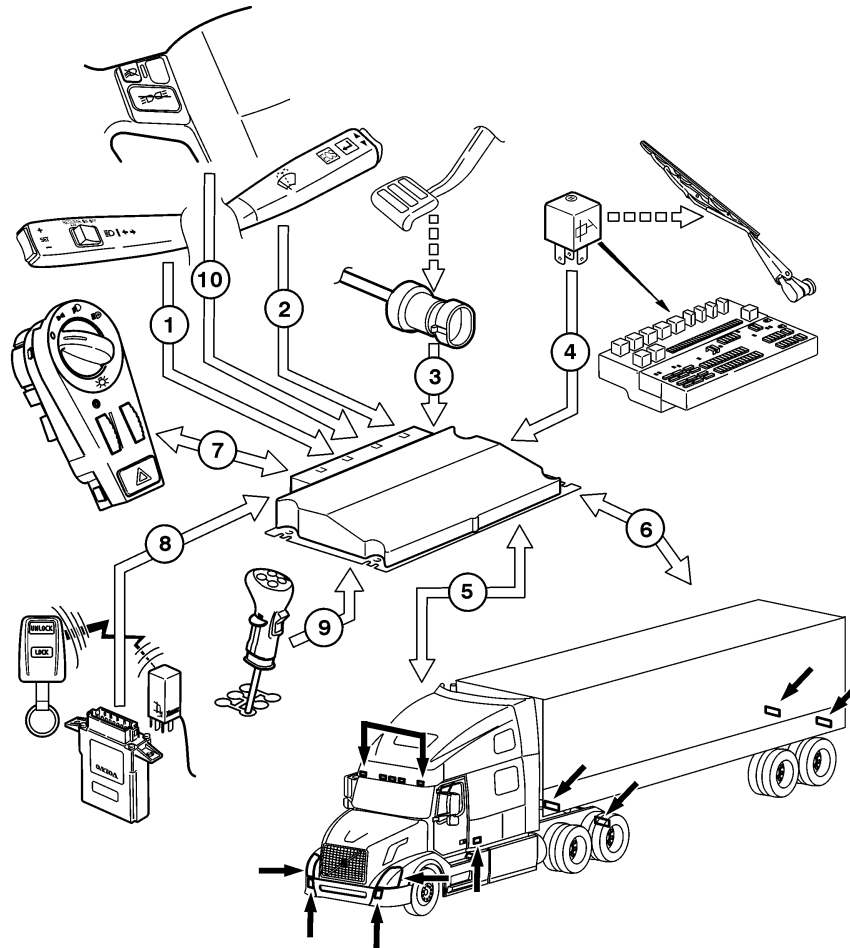

W3005649

- 1 The combination high beam/low beam, turn signal switch transmits signals to the control unit.
- 2 The windshield wiper switch transmits input signals to control intermittent wiping and windshield wiping during windshield washing.
- 3 The brake pressure contacts transmit a signal to the control unit.
- 4 The control unit grounds the intermittent relay to activate the windshield wipers during intermittent wiping and windshield wiping during windshield washing.
Note: The fixed windshield wiper speeds are not controlled by the control unit.
- 5 The control unit supplies power to the tractor exterior lighting.
- 6 The control unit supplies power to the trailer exterior lighting when a trailer is connected.
- 7 The light control panel transmits signals to control the external lighting functions. Also, controls the dash and instrument cluster backlighting.
- 8 The central locking system transmits input signals to the control unit.
- 9 The reverse switch transmits an input signal to the control unit.
- 10 The control unit receives a signal from the steering wheel module for the headlamp and marker lamp interrupts.

Add-on Exterior Lighting

With the LCM controlling the exterior lighting, there are many things to consider with exterior lighting add-ons:

- The dash switches (or any switch providing an input to the LCM) cannot be used as a point to splice into lighting circuits; all added lighting must connect to the LCM outputs only.
- Because of the built-in circuit-breaker function of the LCM outputs, extra care must be used when adding devices. If the added current 'trips' the circuit breaker, the LCM will shut down that entire circuit and set a fault code. Guidelines are given below concerning how much additional current is allowed for common lighting circuits.
- Some exterior lighting circuits, even though controlled by the LCM, still operate using their own fuse and relay. This is done when the requirements of a lighting circuit exceed the LCM's amperage capacity on a single output pin. One example is the trailer STOP lamp circuit; this circuit is protected by a 30A fuse to allow for triple trailers in some markets.

All wiring added outside of the cab must use sealed/weatherproof connections, either using sealed connectors, soldering and covering with glue-lined heatshrink tubing, or making the connections inside of a weatherproof junction box. Simply covering an exterior splice or connection with electrical tape is NOT acceptable weatherproofing. Interior wiring does not need to be weatherproofed, but it must be properly insulated.

When adding exterior lighting, there are generally three options:

- 1 Using the information that follows, determine if the added lighting can be handled through the LCM.
- 2 Add the lighting through a separately fused relay which is controlled by the LCM.
- 3 Bypass the LCM entirely and run a separately fused switch and circuit to power the lighting.

Because the LCM is monitoring the outputs for both excessive current (indicating a short circuit) as well as insufficient current (indicating an open circuit or blown lamp filament), any changes to the factory-installed lighting may result in error codes being generated by the LCM.

This includes but is not limited to:

- Removing factory-installed lighting;
- Replacing factory-installed incandescents with LED lamps;
- Adding lights in parallel to the factory-installed lamps;
- Using replacement lamps of a different wattage than listed in the accompanying bulb replacement guide.

Certain diagnostic limits are adjustable using VCADs or by downloading new software for the LCM. Be aware that you may need to perform these changes to the LCM software if any changes are made to the factory-installed lighting.

To avoid problems, follow the guidelines and recommendations in this document carefully.

For further information refer to:

- "Determining if the Added Lighting can be handled through the LCM ECU", page 149
- "Notes", page 149
- "Worksheet for Determining LCM ECU Lighting Loads", page 150
- "Adding the Load through a Separately Fused Relay, Controlled by the LCM", page 151
- "Bypassing the LCM Entirely", page 152

Determining if the Added Lighting can be handled through the LCM ECU

Each of the lighting circuits connected to the LCM outputs were designed to handle a certain maximum load. If the LCM ECU detects more current than 'normal' being used by a circuit, it will turn off that circuit and set a corresponding fault code. Because of this, before adding any lighting, you must determine:

- 1 The maximum capacity of the LCM Output and circuit wiring involved.
- 2 How much of that capacity is currently being used.

The difference is the available capacity for the LCM to drive the added load.

The table that follows should be used as a worksheet to determine if the added lighting load(s) can be connected to the LCM ECU. For determining the actual existing load, it is best to measure the current being drawn using an ammeter. If this is not possible or practical, a less precise method would be to count all of the existing bulbs and bulb types, and calculate the load using bulb manufacturer data.

"Typical Existing Load" is given for information only, based on the typical factory-built lighting system. It will NOT include any special lighting options, or lighting which was added after the vehicle was built.

Note: ALWAYS MEASURE OR CALCULATE THE ACTUAL LOAD BEFORE ANY ADDITIONAL LIGHTING IS ADDED.

Keep in mind that the LCM ECU may not be the limiting factor in how much added load can be safely added to a lighting circuit. The existing wire size of the circuit (shown in the "Worksheet for Determining LCM ECU Lighting Loads", page 150) must also be considered. It was selected based upon the known factory-installed lighting loads, plus a small amount for add-on lighting needs.

If the added load will result in that circuit drawing more than the recommended current for the given wire size and circuit length, even if the LCM were capable of supplying the additional current, the result will be excessive voltage drop and poor lighting performance. The load must not be added in such cases.

Notes

YOU ARE NOT PERMITTED to add additional lighting loads to the following LCM-controlled outputs:

- Headlights, neither High or Low beams
- Front Turn Signals (these double as Daytime Running Lamps)
- Trailer Stop, Park, or Marker lamp relay control circuits (interfacing to the outputs of the relays is permitted)
- Hazard indicator output to the Light Control Panel (LCP) - Circuit 122A
- Instrument Cluster Wake up/Hazard Output - Circuit 121

If additional lighting is added to any of the following circuits, a relay is mandatory. (The capacity of the LCM ECU is limited to the factory loads, plus a relay):

- Left and Right Side Repeater circuits
- Fog Lights (if adding to factory-installed lights)
- Driving Lights (if adding to factory-installed lights)
- Tractor Marker/Clearance lamps (a relay is mandatory whenever a factory-installed roof sign is present)

Worksheet for Determining LCM ECU Lighting Loads

Lighting Circuit/Function	Circuit No.	Wire Size (mm ²)	Max. LCM Load [A]	Typical Existing Load (Note 6)	Actual Existing Load [B]	Available LCM Capacity [A-B]
Power Unit (Tractor or Truck) Loads:						
Fog Lamps (L + R)	35	1.00	10 A	4.3A x 2 = 8.6 A		
Driving Lamps (L + R)	37	1.00	10 A	4.3A x 2 = 8.6 A		
Tractor Rear Tail/Park (including license plate lamp)	90	2.00	6 A	0.6A x 3 = 1.8 A		
Tractor Front Parking Lamps	56F/90A	1.00	6 A	0.6A x 3 = 1.8 A		
Tractor Marker / Clearance (including roof sign) (Note 1)	52	1.00	6 A	LED: 0.75A total INCAND.: 3A total		
Right Side Repeater (Note 2)	113A-A	1.00	2.5 A	2.1 A x 1 = 2.1 A		
Left Side-Repeater (Note 2)	112A-A	1.00	2.5 A	2.1 A x 1 = 2.1 A		
Reverse Lamp(s) - including Back Up Alarm	410	1.00	5.5 A	2.1 A x 1 = 2.1 A		
Back-of-Cab Lamp(s)	139B	1.00	8.5 A	2.1 A x 1 = 2.1 A		
Tractor Right-Rear Stop/Turn	116	2.00	9.5 A	2.1 A x 1 = 2.1 A		
Tractor Left-Rear Stop/Turn	115	2.00	9.5 A	2.1 A x 1 = 2.1 A		
Tractor Loads (See Note 3): Colors correspond to ATA/SAE trailer cable color codes						
Trailer Right Turn (Note 4)	113C (Green)	3.00	15 A	2.1A x 2 = 4.2 A		
Trailer Left Turn (Note 4)	112C (Yellow)	3.00	15 A	2.1A x 2 = 4.2 A		
Trailer Stop Lamp(s) (Note 5)	72 (Red)	5.00	24 A	2.1A x 2 = 4.2 A		
Trailer Park Lamp(s) (Note 5)	51 (Brown)	3.00	16 A	0.6A x 8 = 4.8 A		
Trailer Marker/Clearance Lamps (Notes 1, 5)	53 (Black)	3.00	16 A	0.6A x 8 = 4.8 A		

Note: (1) These circuits are blinked when the Marker Interrupt switch / function is activated.

Note: (2) The vehicle's front turn signals double as Daytime Running Lights (DRLs), and are not suitable for added lighting - DO NOT interface to these circuits. Instead, use either the tractor side-repeater circuits or the Trailer turn signal circuits to add any lighting to the turn signal circuits. A relay MUST be used with the side-repeater circuits.

Note: (3) Trailer loads are connected to either the 7-way J560 trailer connector (for tractors), or to the Lighting Junction Box (es) on straight-trucks. If the vehicle is equipped with both a J560 trailer cable and a junction box, or multiple junction boxes, all connections must be accounted for when calculating the total load.

Note: (4) The trailer turn signal circuits are driven directly by the LCM ECU. The MAXIMUM LCM LOAD indicated is the steady-state on-current, though the circuit will always have a 50% duty cycle due to the turn signal flashers. Use the steady-state currents when determining loads.

Note: (5) These trailer circuits are LCM-controlled through a relay. The circuit numbers, existing wire size, and MAX. LOAD indicated are for the load side of the relays, not the LCM outputs. DO NOT interface to the LCM circuits that control these relays - use the circuits indicated only.

Note: (6) "Typical existing load" consists of:

- (A) standard tractor lighting (no LED tail-lighting, no roof sign)
- (B) One 40' trailer without ABS (or ABS powered off of AUX circuit)

Adding the Load through a Separately Fused Relay, Controlled by the LCM

If it is determined that the added load cannot be driven directly by the LCM output, but the output has enough available current to drive a relay coil (typically under 200 mA for an 80Ω relay coil), then the best choice is to connect the new load through a separately fused relay; an example is shown below.

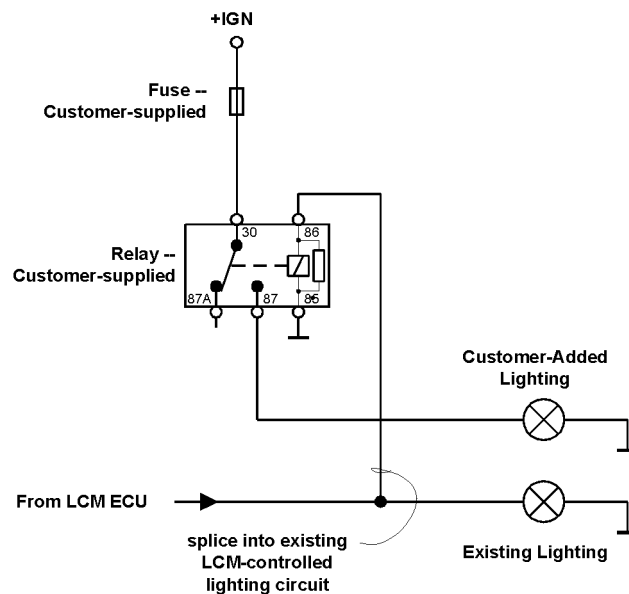

W9000656

Bypassing the LCM Entirely

If the LCM output cannot support either the added load or a relay, then the only choice is to bypass the LCM and run a dedicated fuse and switch to control the added lighting. (Even if the LCM can support the load, this method may be preferable when adding certain loads, either to achieve the desired operation independent of the LCM, or to make fault isolation and troubleshooting easier.

Power for the added lighting can be obtained either from one of the BAT or IGN expansion buses in the right-rear section of the Fuse and Relay Center (preferable, since there will be an available fuse slot for that circuit), or by adding an in-line fuse holder.

Transmission Control Module

Several electronically-controlled transmissions are available, depending on engine and vehicle type:

- Volvo I-Shift
- Eaton AutoShift
- Eaton Lightning
- ZF/Meritor FreedomLine
- Allison Automatic

Each of these transmissions uses a Transmission Control Module (TCM) which interfaces to the vehicle system and vehicle databuses. All of the transmissions use the ISO 2 databus to direct the engine into certain operating modes, either to facilitate smoother shifts, synchronize engine speed to driveline speed, or allow/disallow engine braking.

The TCMs are located as follows:

- Volvo I-Shift – TCM is located on the top of the transmission.
- Eaton AutoShift – one TCM (system TCM) in the shift pad, one is mounted to the left side of the transmission.
- Eaton Lightning – TCM located on the transmission, back side above the tail shaft.
- ZF/Meritor FreedomLine – TCM is mounted on top of the transmission.
- Allison Automatic – TCM is mounted to the bracket attached to the driver's seat.

The transmission electronics and their interaction with the rest of the vehicle systems is a very important interface, one which affects many aspects of the vehicle operation and safety.

Note: Volvo Trucks North America does not recommend any circuit modifications, alterations, or additions to any of the transmission electronics, including sensors and actuators used by the transmissions.



CAUTION

DO NOT interface to, modify, or alter any of the sensors or circuits used by the Transmission TCMs.

Refer to the appropriate service manual for all service information. Refer to the VN/VHD schematics for details on how each transmission TCM interfaces to the vehicle. Refer to the appropriate transmission manufacturer's literature for all service procedures and details on the transmission TCMs.

Refer to "Datalink Link Flow", page 52 for a detailed layout of the data link backbone.

Vehicle Electronic Control Unit (VECU)

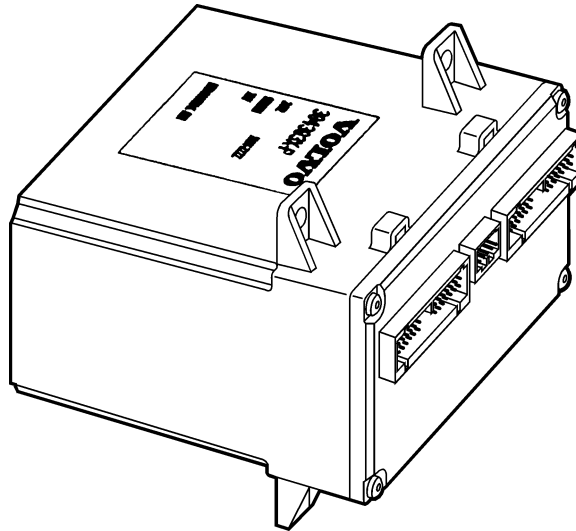

W2002673

The Vehicle ECU (VECU) is responsible for gathering operator control information and sending it to other ECUs using the databases. The primary user of the information is the Engine ECM, but other ECUs use some of the information such as park brake status, clutch and brake switches, etc.

The following signals and controls are used as inputs to the VECU:

- Cruise Control Stalk Switch(es)
- Accelerator Pedal and Idle Validation Switch
- Ignition Keyswitch
- A/C Pressure Status
- Park Brake Status
- PTO Dash Switch (Volvo Engine Only)
- Brake and Clutch Pedal Switch(es)
- Brake Pressure Switch
- Engine Brake Switches/Selectors
- Vehicle Speed Sensor (VSS)

The VECU processes these inputs and sends their status to other ECUs using both the J1587/1708 information data link and J1939 control data link. In addition to these 'logical' outputs, the VECU controls several physical outputs as well such as:

- Redundant (wired) Idle Validation Switch (IVS) signals to the ECM
- ECM Power Supply (Volvo Engine Only)
- PTO Output (Volvo Engine Only)

The VECU is used with both Volvo and Cummins engines. Although the electronic 'language' that the VECU uses to communicate is the same, the way it communicates between the two engine types can vary. With a Volvo Engine, the VECU and ECM split responsibility between the two for functions such as Cruise Control, PTO and Engine Brake Control. The Cummins engine, uses the VECU as an input multiplexer to send the status of various controls for the engine to use.

With the Volvo engine, the VECU can be combined with the Body Builder Module (BBM) ECU to implement many of the auxiliary body builder functions within the engine.

Parameter List

Group	DOID	OBD2013 Electrical System Version 3 Parameter	Caption	Description
Cruise Control	AI	AI	Cruise Control Max Speed	The maximum speed that can be set in the cruise control.
Engine Fan Controls	P1I2F	FTX	Fan Enable With Engine Brake	This flag will enable the fan with the engine brake. 0 = Disabled, 1 = Enabled
Engine Governor	P1I03	AZQ	High Idle Governor For High Gears	Engine speed where the governor output crosses the max torque curve. Used for high gear ratios.
	P1I04	AZO	High Idle Enable Flag For Low Gears	If this flag is set to TRUE, it is possible to use a higher end governor engine speed for low gears.
	P1I05	AZR	High Idle Gear Ratio For Low Gears	Gear ratio for the gear P1I03 should be used. For higher gears the end governor engine speed is used.
	P1I18	AZS	High Idle Ratio For High Gears	Gear ratio for the gear where end governor engine speed is used. For lower gears the P1I03 setting should be used.
Engine Idle Settings	P1F9W	YA	Engine Idle, Target Speed	Target engine speed at idle.
Engine Speed Limit	P1ANA	AU	Max Engine Speed Stationary	Maximum engine speed allowed when the vehicle is stationary. The maximum engine speed varies between approximately 1200 - 2600 rpm depending on engine type.
	P1I04	AZO	High Idle Enable Flag For Low Gears	If this flag is set to TRUE, it is possible to use a higher end governor engine speed for low gears.
	P1IDB	BNQ	Max Engine Speed with a Vehicle Speed Error	Specifies the max engine speed when a vehicle speed error is active.
Engine Torque Limit	P1JED	JAA	PTO Through Driveshaft, Enables	Configures if PTO is enabled through driveshaft. If set to 1, torque limit for low vehicle speed is deactivated. 0 = Disable, 1 = Enable
Injection Control	P1AM4	ATJ	Injector Cylinder 1, Calibration	The new trim code must be programmed after replacing the unit injector. The trim code (T/C) is shown on the injector
	P1AM5	ATK	Injector Cylinder 2, Calibration	

Group	DOID	OBD2013 Electrical System Version 3 Parameter	Caption	Description
	P1AM6	ATL	Injector Cylinder 3, Calibration	label and consists of up to 9 characters.
	P1AM7	ATM	Injector Cylinder 4, Calibration	
	P1AM8	ATN	Injector Cylinder 5, Calibration	
	P1AM9	ATO	Injector Cylinder 6, Calibration	
	P1G3E	IVT & JAN	Injector Performance Log	Reset has to be done after injector change, by using the routine control: R1AFI - Reset of Target Torque Reference Value.
Miscellaneous Engine Settings	P1ALZ	AIZ	Fuel Consumption, Calibration In Percent	A percentage correction value to compensate any deviation between the calculated fuel consumption shown in the Driver Information Display and the fuel consumption according to the customer's fuel protocol.
	P1AOF	DX	Cust Data, Engine ECU Password	Password to allow changing of parameter values on this vehicle. If a password is in place, correct entry of the password will be required when changing parameter values.
	P1IEA	JZF	Smart Torque, Enable	Enables the Smart Torque function.
	P1IRK	MYD	Accelerator Limiter, Enable	Enables the Accelerator Limiter function. 0 = Disabled, 1 = Enabled
	P1I07	9G	Diff RSL, Transmission Ratio Highest Gear	The gearbox ratio in the highest gear. The ratio can be found in the gearbox specifications. The ratio must be entered in order for the control module to calculate which gear is selected.
Miscellaneous Engine Settings	P1I08	9H	Diff RSL, Transmission Ratio Next Highest Gear	Gearbox ratio second highest gear.
	P1AOD	DV	Diff RSL, Max VSPD Next Highest Gear	Speed limitation when the second highest gear is selected. The value must be lower than parameter P1AOC. Do not use with AMT gearboxes.

Group	DOID	OBD2013 Electrical System Version 3 Parameter	Caption	Description
	P1AL0	AJ	Diff RSL, Enable / Disable	Activating different speed limitations when driving in the highest or second highest gear. This function is used if the maximum speed can only be reached when the highest gear is engaged. Parameters P1AOD, P1ALW/P1107 and P1ALX/P1108 must be programmed if this function is activated. 0 = Disabled, 1 = Enabled
Miscellaneous Vehicle Settings	P1HUB	FTM	Soft Cruise Enable	Enable the soft cruise functionality. 0 = FALSE, 1 = TRUE
	P1107	9G	Diff RSL, Transmission Ratio Highest Gear	The gearbox ratio in the highest gear. The ratio can be found in the gearbox specifications. The ratio must be entered in order for the control module to calculate which gear is selected.
	P11P6	DN	Customer Data Fleet Identifier	Customer Data Fleet Identifier = "Fleet ID" = "Unit Number" : The Customer Fleet Identifier can be set via the cluster menu by the customer.
	P1APZ	IEH	Transmission Kick-down Mode	This parameter defines when the Kick-down function is available.
	P1ARH	IPA	Number of Reverse Gears	Setting determines the number of reverse gears available.
	P1ASL	LAQ	Highest Start Gear in Manual Mode	The adjustment of start gear in manual mode will be restricted to gears equal to or lower than this value.
	P1ASM	LAR	Highest Start Gear in Automatic Mode	The selection and adjustment of start gear in automatic mode will be restricted to gears equal to or lower than this value.
	P1FP0	NXK	Enable Split box Start with Accelerator Pedal	False = Split box started when the gear lever moved from Neutral to Automatic or Manual. True = The split box is not started until also the accelerator pedal is depressed. This will provide additional torque backup for the split box start.

Group	DOID	OBD2013 Electrical System Version 3 Parameter	Caption	Description
	P1FP2	NUO	Enable I-Roll Only When Cruise Control (CC) Active	True = I-Roll will only be allowed when CC is active. False = I-roll allowed both for pedal- and cruise control driving.
Miscellaneous Vehicle Settings	P1IK3	MUF	Highest Adjustable Gear in Manual Mode	The highest adjustable gear in manual mode. If gear lever is moved to manual in a higher gear than the highest adjustable gear in manual, no manual adjustments will be allowed. The function prohibits the driver to drive in a gear that is too low, which will increase fuel consumption. This is only valid in economy mode.
	P1IZ5	PPQ	Transmission Automatic Pedal Gear Enable Manual Adjustment	Enables the driver to manually adjust the automatic selected driving gear with gear selection +/- buttons when the accelerator pedal is depressed.
	P1JZ7	LAP	Start Gear Depend On ECS Manual Control Mode	Start gear selection dependence on ECS manual control mode. 0 = The selected start gear is not lowered during ECS control mode. 1= The selected start gear is lowered during ECS control mode. 2 = The selected start gear is lowered both during and after ECS control mode. Use this setting to avoid starting at a high gear before the air suspension has been raised from the beam stops during manual control mode.
Miscellaneous Vehicle Settings	P1G42	JSI	Minimum DPF Inhibit Target Speed Limit	Minimum road speed limit (RSL) during DPF inhibit.
	VINNO	VIN	Vehicle Identification Number	17 character VIN Number
	P1AOD	DV	Diff RSL, Max VSPD Next Highest Gear	Speed limitation when the second highest gear is selected. The value must be lower than parameter P1AOC. Do not use with AMT gearboxes.
	P1AL0	AJ	Diff RSL, Enable / Disable	Activating different speed limitations when driving in the highest or second highest gear.

Group	DOID	OBD2013 Electrical System Version 3 Parameter	Caption	Description
				This function is used if the maximum speed can only be reached when the highest gear is engaged. Parameters P1AOD, P1ALW/P1107 and P1ALX/P1108 must be programmed if this function is activated. 0 = Disabled, 1 = Enabled
Power Take Off #1 (PTO 1)	P1AO5	GJG	Split Gear for Transmission PTO1	Split gear used when transmission PTO1 is engaged. Low split has priority over high split if PTO1 and PTO2 are both engaged and have conflicting (split gear) settings.
Power Take Off #2 (PTO 2)	P1AO6	GJH	Split Gear for Transmission PTO2	Split gear used when transmission PTO2 is engaged. Low split has priority over high split if PTO1 and PTO2 are both engaged and have conflicting (split gear) settings.
Road Speed Limit	P1AOD	DV	Diff RSL, Max VSPD Next Highest Gear	Speed limitation when the second highest gear is selected. The value must be lower than parameter P1AOC. Do not use with AMT gearboxes.
	P1AOC	DP	Customer Road Speed Limit	Specifies the customer selectable maximum speed the vehicle can operate on level road. The vehicle speed will be limited by the lowest of the following: Customer Road Speed Limit (P1AOC), Road Speed Limit (P1ALV) and Secondary Road Speed Limit (Request via CAN-signal from Body Builder Module) if available. For markets that use performance bonus: Any additional speed granted by the Performance Bonus feature will be added to the Customer Road Speed Limit (P1AOC) value, as (so) long as the overall maximum of 140km/h (87 MPH) is not exceeded. Any speed penalty imposed by the Differential Road Speed Governor will be subtracted from this maximum value. Max Cruise Control Speed must be set less than or equal to the

Group	DOID	OBD2013 Electrical System Version 3 Parameter	Caption	Description
				accelerator-pedal maximum specified by the Customer Road Speed Limit (P1AOC) value.
	P1I01	FTP	RSL Enable Soft Cruise Functionality	Enable the soft cruise functionality for RSL (Road Speed Limit). 0 = Not enabled, 1 = Enabled
Road Speed Limit	P1AL0	AJ	Differentiated RSL, Enable	Activating different speed limitations when driving in the highest or second highest gear. This function is used if the maximum speed can only be reached when the highest gear is engaged. Parameters P1AOD, P1ALW/P1I07 and P1ALX/P1I08 must be programmed if this function is activated. 0 = Disabled, 1 = Enabled
	AI	AI	Cruise Control Max Speed	The maximum speed that can be set in the cruise control.
	P1I07	9G	Diff RSL, Transmission Ratio Highest Gear	The gearbox ratio in the highest gear. The ratio can be found in the gearbox specifications. The ratio must be entered in order for the control module to calculate which gear is selected.
	P1I08	9H	Diff RSL, Transmission Ratio Next Highest Gear	Gearbox ratio second highest gear.
	P1I09	9D	Road Speed Limit Maximum	The maximum vehicle speed. In certain countries the maximum speed is determined by legal requirements.
	P1I16	PPE	Road Speed Limit With Pedal	The pedal vehicle speed limit which is used to set a higher or lower pedal vehicle speed. Its intended to be used together with Road speed limit function to make the driver want to use cruise control.
	P1G42	JSI	Minimum DPF Inhibit Target Speed Limit	Minimum road speed limit (RSL) during DPF inhibit.
	Fuel Economy Incentive Program	P1I0G	ADZ	Performance Bonus Enable

Group	DOID	OBD2013 Electrical System Version 3 Parameter	Caption	Description
	P110H	ADX	Performance Bonus Fuel Target	Specifies the fuel consumption [km/l] target value for the Performance Bonus function.
	P110I	FXA	Performance Bonus Fuel Penalty Target	Specifies the penalty target value for fuel consumption [km/l]. Below this target value the driver will lose speed as a penalty.
	P110J	ADY	Performance Bonus Idle Target	Specifies the percentage value for Idle time below which the driver gets a performance bonus.
	P110K	FWX	Performance Bonus Sweet Spot Target	Specifies the amount of time the driver must spend in the sweet spot to get a performance bonus.
	P110N	FWY	Performance Bonus Function Mode	Sets the Performance Bonus function mode. 0 = Bonus, 1 = Penalty, 2 = Bonus and Penalty
	P110L	FWZ	Performance Bonus Parameters	Sets the Performance Bonus running mode: 0 = No targets, 1 = Fuel, 2 = Idle
	P110M	BTR	Performance Bonus Number of Steps	Specifies the number of steps for the Performance Bonus. There are 1-3 steps.
	P110P	AEB	Performance Bonus Vehicle Speed Bonus	The delta value to adjust the customer vehicle speed limit for the Performance Bonus function.
	P110Q	FXD	Performance Bonus Vehicle Speed Penalty	The delta value to decrease the customer vehicle speed limit with during penalty for the Performance Bonus function.
Fuel Economy Incentive Program	P1AP3	IEO	Transmission Performance Mode	0 = "Manual" = Performance mode available. 1 = "Auto" = Performance mode available. The transmission will automatically return to Economy mode when the engine is no longer operating under high load. 2 = "Disable" = Performance mode not available"
	P11K0	IHL	Performance Bonus II - Enable K-D and P as Reward	Enables the Kick-Down and /or the Performance mode only when the driver is rewarded by Performance Bonus II. This

Group	DOID	OBD2013 Electrical System Version 3 Parameter	Caption	Description
				feature requires that at least one of the parameters P1AP3, (Enable Performance Mode) and P1APZ, (Enable Kick-Down) are enabled.
	P1IK1	IEG	Transmission I-Roll Function Enabled	Enable the transmission free wheeling function I-Roll.
	P1IK2	IEK	Lowest I-Roll Gear	The lowest gear in which the I-Roll function is enabled.
	P1I53	ADV	Performance Bonus Effective Distance	The effective distance, all mean values relates to this distance.
	P1JGX	NXI	Vehicle Mass Estimation Eco Level Enabled	1 = Scales the weight for Vehicle Mass Estimation via the Eco Level Map. 0 = Eco Level Map not used for Vehicle Mass Estimation. Vehicle Mass Estimation will not work without this value set to 1!
	P1INE	PDM	Eco Level Used in SoftCruise Function	Forced Eco Level used in SoftCruise function.

Notes

Switches and Controls

Dash Switch Overview

Note: Information is subject to change without notice.

Illustrations are used for reference only and may differ slightly from the actual vehicle being serviced. However, key components addressed in this information are represented as accurately as possible.

All dash-mounted switches feature heavy duty terminals and locking mating connectors. Rocker switches have illuminated legends with embedded LEDs to indicate **ON** or **OFF** status of electrical devices.

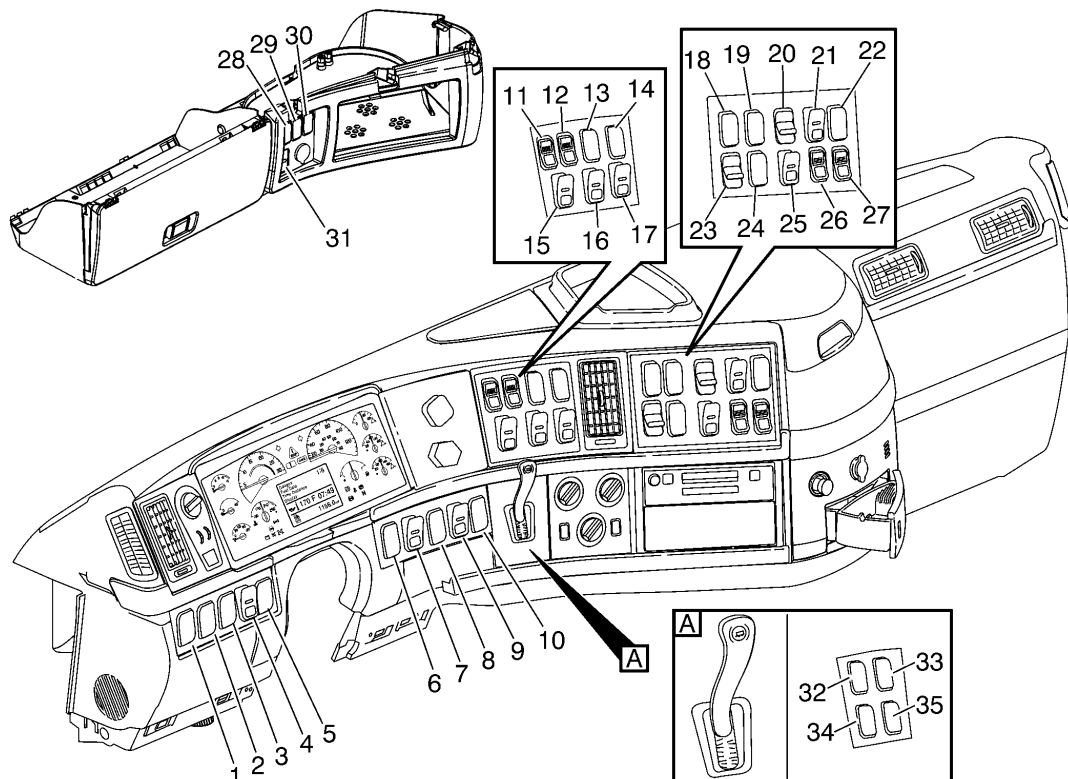

W3007481

Note: See the following page for illustration call outs.

VN and VT Switch Location

- 1 Back of Cab Light
- 2 Optional Switch (Open)
- 3 Optional Switch (Open) or PTO (Transmission/Engine)
- 4 Overhead Bunk Lamp or Passenger Side Mirror IN/OUT
- 5 Side Mirror Heat or PTO #2 (Transmission)
- 6 Optional Switch (Open) or Passenger Window Lift
- 7 Water in Fuel (Purge Switch)
- 8 Optional Switch (Open) or Beacon Lamp(s)
- 9 Sleeper Fan Speed
- 10 Optional Switch (Open) or IPOD/MP3 Receptacle
- 11 Inter-wheel Differential Lock
- 12 Inter-axle Differential Lock
- 13 Idle Management Indicator Lamp (ISX ICON) or Optional Switch (Open) or Elec. Controlled Suspension On/Off or Lift Axle #1 (Pusher)
- 14 Optional Switch (Open) or Elec. Controlled Suspension Up/Down
- 15 Aux #1
- 16 Aux #2 or Temp-A-Start (TAS) Indicator Lamps
- 17 Aux #3 or Temp-A-Start (TAS) On/Off
- 18 Secondary Gauge Cluster
- 19 Secondary Gauge Cluster
- 20 Engine Brake or I-Shift Eco-Roll
- 21 Engine Brake Mode Select (ISX) or I-Shift Hill Start Assist
- 22 5th Wheel Touch Lock (Unlock) or Heated Windshield
- 23 Marker Interrupt or Secondary Gauge Cluster
- 24 Optional Switch (Open) or Secondary Gauge Cluster
- 25 Traction Control
- 26 Suspension Dump
- 27 5th Wheel Slide
- 28 Optional Switch (Open)
- 29 Optional Switch (Open)
- 30 Optional Switch (Open)
- 31 AC Inverter 120 V On/Off and Shore Power Indicator Lamp
- 32 Optional Switch (Open)
- 33 Optional Switch (Open)
- 34 Optional Switch (Open)
- 35 Optional Switch (Open)

VHD Switch Location

- 1 Back of Cab Light
- 2 Optional Switch (Open)
- 3 Optional Switch (Open) or PTO (Transmission/Engine)
- 4 PTO Engine; Side A
- 5 PTO Engine; Side B or PTO #2 (Transmission)
- 6 Optional Switch (Open)
- 7 Water in Fuel (Purge Switch)
- 8 Beacon Lamp(s)
- 9 Snow Plow Lamp(s)
- 10 Optional Switch (Open) or IPOD/MP3 Receptacle
- 11 Inter-wheel Differential Lock
- 12 Inter-axle Differential Lock
- 13 Lift Axle #1 (Tag or Pusher)
- 14 Lift Axle #2 (Tag or Pusher)
- 15 Aux #1
- 16 Aux #2
- 17 Aux #3 or Lift Axle #3 (Tag or Pusher)
- 18 Secondary Gauge Cluster
- 19 Secondary Gauge Cluster
- 20 Engine Brake or I-Shift Eco-Roll
- 21 Optional Switch (Open) or I-Shift Hill Start Assist
- 22 Transmission Retarder
- 23 Marker Interrupt or Secondary Gauge Cluster
- 24 Secondary Gauge Cluster
- 25 Traction Control
- 26 Suspension Dump
- 27 5th Wheel Slide or Engine Inside/Outside Air Control
- 28 Optional Switch (Open)
- 29 Optional Switch (Open)
- 30 Optional Switch (Open)
- 31 Optional Switch (Open)
- 32 Optional Switch (Open)
- 33 Optional Switch (Open)
- 34 Optional Switch (Open)
- 35 Optional Switch (Open)

Dash Switches

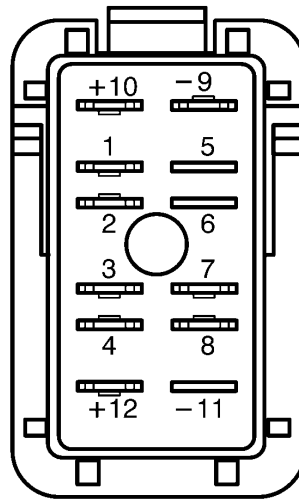

W3007201

The following tables list the available dash switches for the dash switch panels. Not all switches are standard and can vary from vehicle to vehicle. Extra switches and switch connectors are available through Volvo Parts NA.

Switch Handle Styles:

- 1 Normal Rocker
- 2 Rocker with Paddle Handle
- 3 Rocker with Safety Interlock
- 4 Stationary Indicator Lamps

Note: Handle styles are available with different switch functions; consult the tables for the available combinations.

Switches have a common connector configuration and terminal identification.

All switches have LED backlighting with an internal current-limiting resistor. The backlighting is controlled by terminals 10 (+V) and 9 (Ground).

Some switches have a pilot lamp (LED) in the center of the switch. This is to indicate when the switch or load is turned "ON".

All switches mount with the switch legend towards the bottom. For most switches, the "ON" position occurs when the switch is pushed at the bottom.

Note: Pay special attention to the current ratings of switches. All switches are rated for 12V DC use. Some are rated for 'electronic' loads (100 mA maximum), meaning that they are used only as an input to an ECU and must not be used in general purpose lighting.

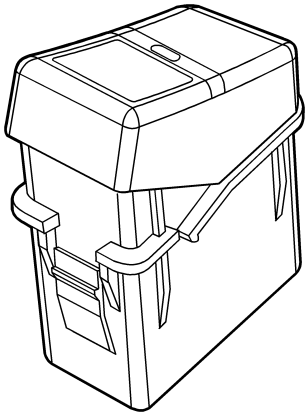

W3000579

Fig. 12 Basic Rocker Switch

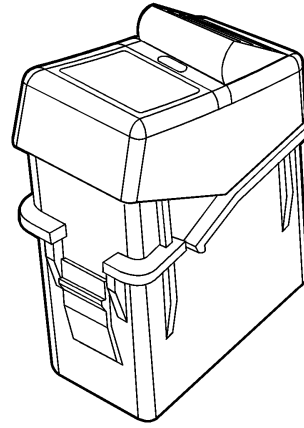

W3004415

Fig. 14 Rocker with Safety Interlock

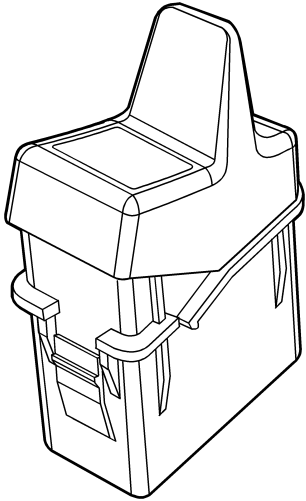

W3000578

Fig. 13 Rocker with Paddle Handle

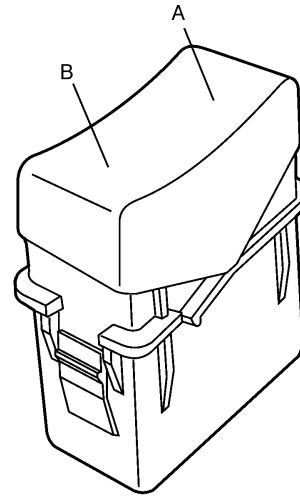

W3007202

Fig. 15 Stationary LED

A Top LED





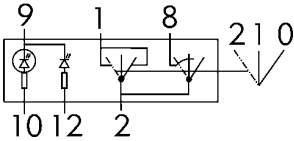
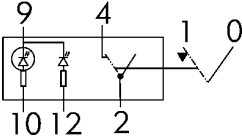
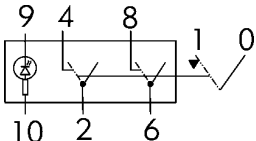
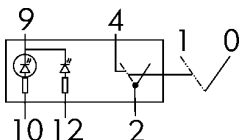
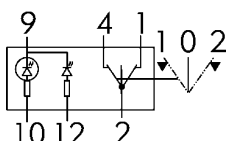
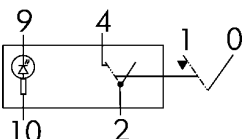
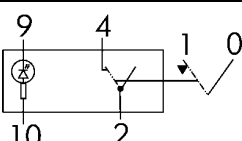
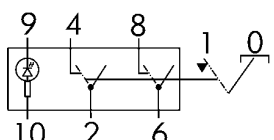
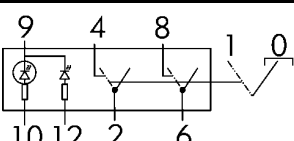
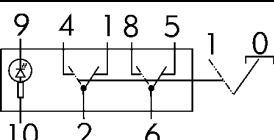
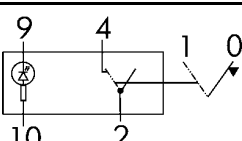

B Bottom LED

Switch Logic	Handle Style	Switch Description
	Basic Rocker	<ul style="list-style-type: none"> AUX ("AUX") Mirror demist Beacon light
	Locking Rocker	<ul style="list-style-type: none"> Inside/outside air intake ("engine air control")
	Basic Rocker	<ul style="list-style-type: none"> Overhead fluorescent lamp Window lift; passenger side Elec. mirror arm passenger side Elec. cont. susp. 6x2 up/down Diff. lock, inter-wheel low range
	Locking Rocker	<ul style="list-style-type: none"> Power take-off, gearbox 1 Power take-off, gearbox 2 Power take-off engine Additional brake; retarder
	Basic Rocker	<ul style="list-style-type: none"> Engine brake, EPG Idle management Temp-A-Start
	Locking Rocker	<ul style="list-style-type: none"> Frame lift; air suspension dump Diff. lock; inter-wheel Diff. lock; inter-axle 5th wheel slide Elec. cont. susp. 6x2 off/on (ECS)
	Rocker with Paddle	<ul style="list-style-type: none"> Engine brake, EPG + VEB; 12V 0-1-2
	Rocker with Paddle	<ul style="list-style-type: none"> Engine brake, Cummins 12V 0-1
	Stationary LED	<ul style="list-style-type: none"> Lamp, Volvo Temp-A-Start; green and red LED's

Switch Logic	Handle Style	Switch Description
	Basic Rocker	<ul style="list-style-type: none"> • Engine brake, Cummins 12V 0-1-2
	Basic Rocker	<ul style="list-style-type: none"> • Water drain fuel filter • Heated windshield
	Basic Rocker	<ul style="list-style-type: none"> • 5th wheel unlock; momentary non-locking
	Basic Rocker	<ul style="list-style-type: none"> • Working light; back-of-cab/5th wheel • Inverter, 120V AC
	Basic Rocker	<ul style="list-style-type: none"> • Sleeper HVAC mode select
	Basic Rocker	<ul style="list-style-type: none"> • Traction control system; shut-off • I-Shift hill start assist
	Rocker with Paddle	<ul style="list-style-type: none"> • Marker lamps interrupter
	Locking Rocker	<ul style="list-style-type: none"> • 5th wheel unlock; momentary
	Locking Rocker	<ul style="list-style-type: none"> • Plow light
	Locking Rocker	<ul style="list-style-type: none"> • Pusher axle lift • Axle lifting, tag axle
	Basic Rocker	<ul style="list-style-type: none"> • I-Shift ECO-Roll

Switch Functionality Legend

Reference the table below to identify switch functionality.

 <p>W3007476</p>	<p>On/Off Maintained</p>
 <p>W3007477</p>	<p>On/Off (Momentary On)</p>
 <p>W3007704</p>	<p>On/Off (Momentary Off)</p>
 <p>W3007479</p>	<p>On/Off Locking</p>
 <p>W3007480</p>	<p>On/Off Locking (Momentary On)</p>
 <p>W3007478</p>	<p>On/Off/On (Momentary, With Center Off Position)</p>

Door Switches

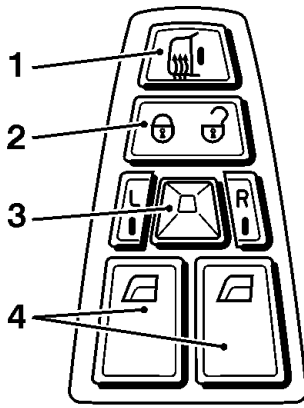

W8003087

Fig. 16 Switch on Driver's Door

- 1 Mirror Heat Switch
- 2 Door Lock/Unlock Switch
- 3 Mirror Control Switch
- 4 Power Window Switches

The passenger side may only include a window switch to control the right window.

Stalk Switches

Wiper/Washer Switch

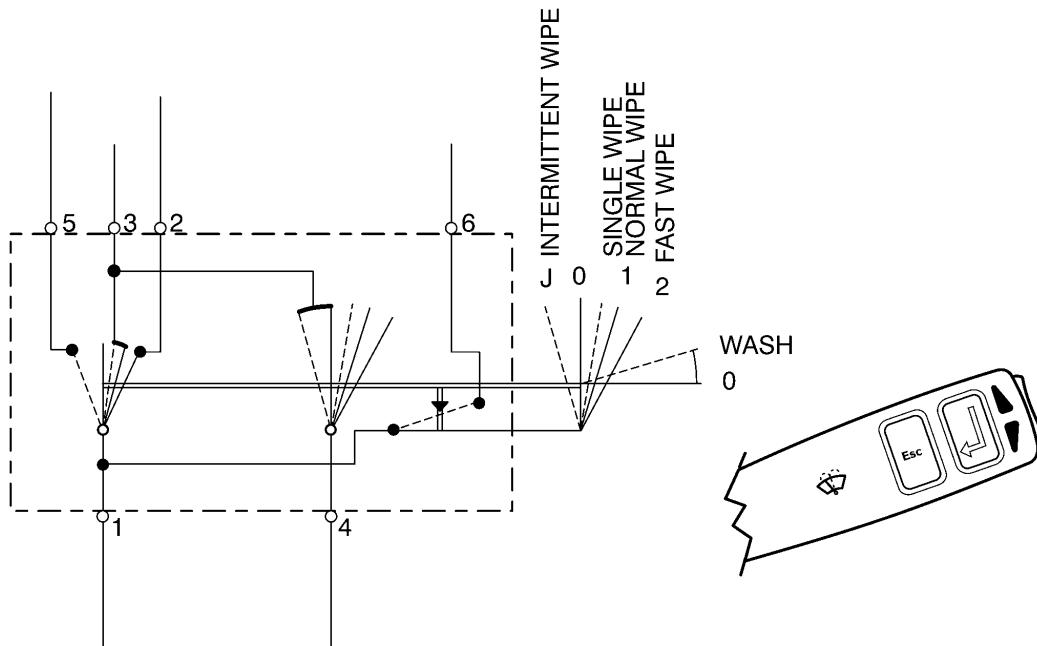

W3056867

Fig. 17 Wiper/Washer Switch

Controls for the windshield wiper/washer are on the stalk on the right-hand side of the steering column.

Intermittent wipers are preset to make a single sweep every 10 seconds. The interval can be set to between 1 and 10 seconds by moving the wiper stalk to the intermittent position, then to off, then to intermittent again when another sweep is desired.

Wiper/washer Switch Connector	
Pin	Description
1	12V Supply to Wiper Switch
2	High Speed Wiper
3	Low Speed Wiper (Normal)
4	LCM Input Signal (wiper motor active)
5	12V Input to LCM (intermittent function)
6	12V Supply to Washer Motor

Graphic Display Switch

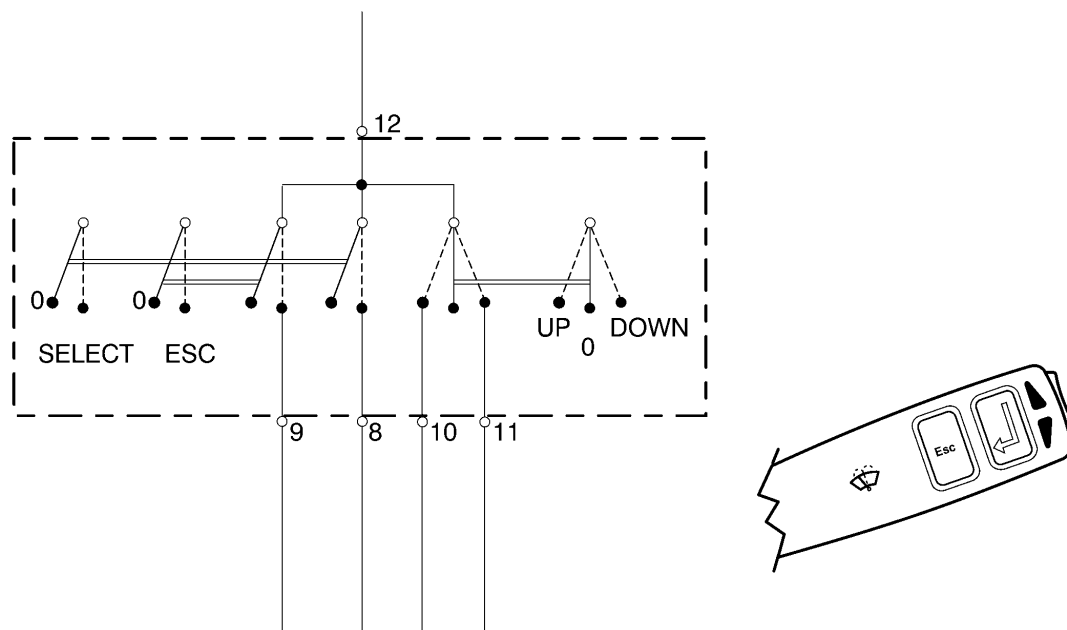

W3056868

Fig. 18 Graphic Display Esc/Select Switch

Note: Numbers inside parenthesis are circuit numbers

Controls for the instrument cluster's graphic display window are located on the stalk switch to the right of the steering column. The Esc and Select buttons allow for different vehicle information to be displayed. The up and down buttons at the end of the stalk are used to scroll through the various display menus.

Graphic Display Switch Connector	
Pin	Description
8	"SELECT" Input
9	"ESCAPE" Input
10	"UP" Input
11	"DOWN" Input
12	Common 12V Supply

Cruise Control, Turn Signal and Headlamp Dimmer Switch

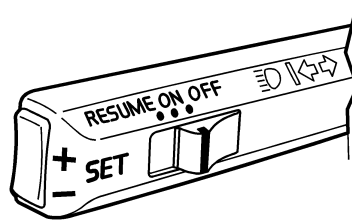

W3002499

Fig. 19 Cruise Control Switch

The controls for turn signals, cruise control, and high beam/low beam selection are on the stalk switch on the left-hand side of the steering column.

The high beam/low beam switch works by pulling back on the stalk. This switch includes a "flash to pass" feature.

Increase or decrease the engine speed by pressing the button at the end of the stalk. Pressing the top of the button, toward the + sign, will increase vehicle speed while pressing the lower part of the button, the - sign, will decrease speed. To return to the set speed, move the switch on the stalk toward "Resume".

The cruise control switch may also be used to control engine speed on vehicles equipped with PTOs.

Vehicles equipped with SmartCruise are capable of applying the Volvo Engine Brake (I-VEB) and throttle back the engine to slow the vehicle when deemed necessary by the appropriate control modules. With the engine brake stalk in the "A" position, the I-VEB may be engaged to control over speed when rolling down a hill. This is an automated feature and no drive input is necessary once the desired cruise over speed is set.

Left Hand Stalk Switch Connector (14-way)	
Pin	Description
1	Common
2	Cruise control On
3	Cruise control Resume
4	Cruise control Set -
5	Cruise control Set +
6	Not used

Left Hand Stalk Switch Connector (14-way)	
7	Not used
8	Not used
9	Not used
10	Flash-to-pass to LCM
11	Hi/Low select to LCM
12	Left turn to LCM
13	Right turn to LCM
14	Common ground

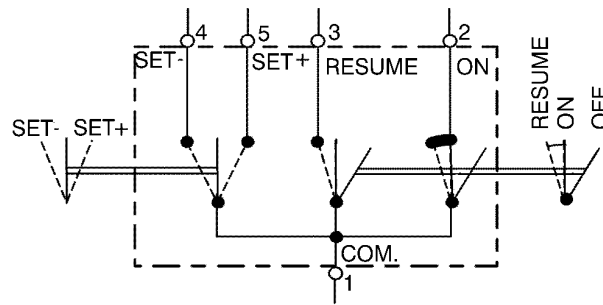

W3056869

Fig. 20 Cruise Control Switch Logic Diagram

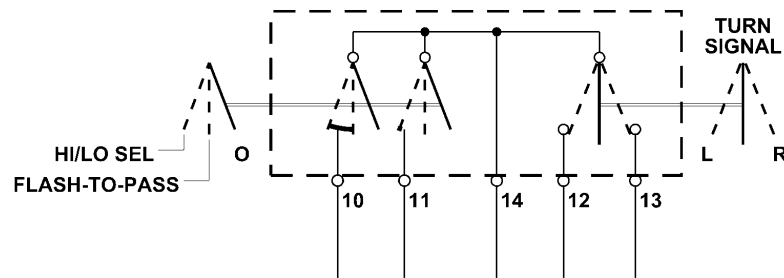

W3056870

Fig. 21 Turn Signal and High/Low Beam Switch Logic Diagram

Note: The turn signal and hi/lo beam switches are logic switch inputs to the Light Control Module (LCM). They do not carry any significant current load (approximately 0.1 Amp or less).

Light Switch

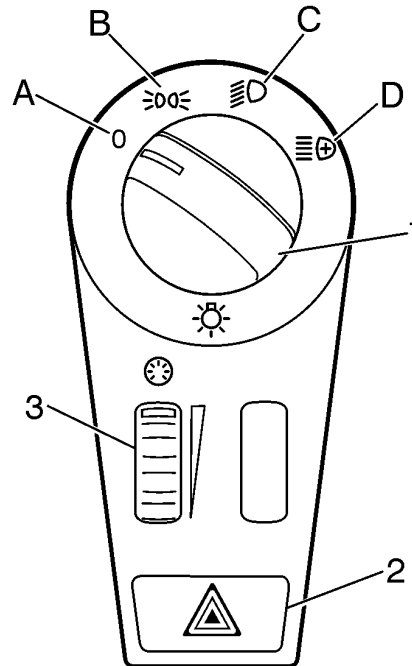

W3005653

The illustration shows the premium version of the switch. The other option does not have the “Drive +” position.

External lighting functions are controlled via the Light Control Panel (LCP). The switch has three controls and three indicator lights (hazard warning lights are indicated by a flashing signal in the switch and turn signal flashing in the cluster).

When the selected function is activated an input on the LCM is grounded.

Indicator lights are supplied with power by the LCM when the relevant function is active.

1 Light switch

- A** “Off” -position
- B** “Park” -position
- C** “Drive” -position
- D** “Drive +” -position (optional fog/driving lights)

2 Hazard warning lights switch/Hazard warning light indicator light

3 Rheostat for dash lighting

Ignition Switch

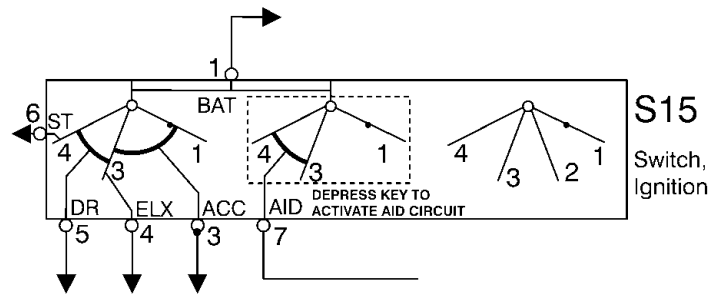

W3056871

Fig. 22 Ignition Switch Logic Diagram

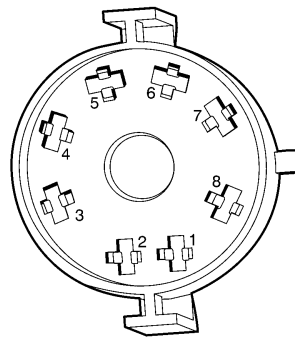

W3006747

Fig. 23 Ignition Switch Connector Detail

The chart below gives the pin and circuit description.

Note: The ignition switch and door locks use the same key. Replacement keys can be ordered from Volvo by key code or cut by a local key cutter if desired.

Pin	Description	Switch Label
1	+12V Battery Power Supply	(BAT)
2	Not Connected	(BAT)
3	Accessory Power Feed	(ACC)
4	Ignition / Auxiliary Power Feed	(ELX)
5	Ignition (Drive) Feed	(IGN)
6	Starter Relay Feed	(ST)
7	Preheat Request	(AID)
8	Not Connected	

Switch Position

The following illustrations detail the new switch position layout. **The new switch does not detail the positions on the switch itself. Use these illustrations as a reference when servicing the vehicle.**

Note: For preheat, turn to Position C and push inward on the key.

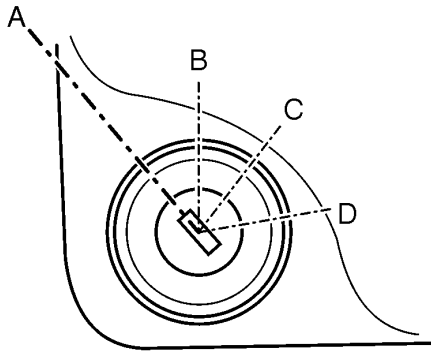

W3006726

Switch Position A = Radio/Accessories

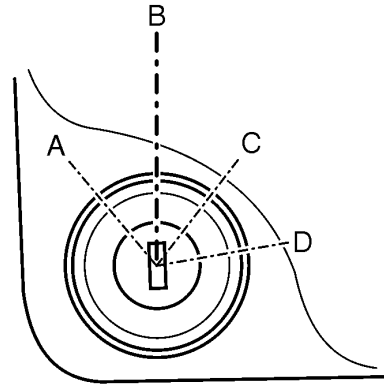

W3006727

Switch Position B = OFF

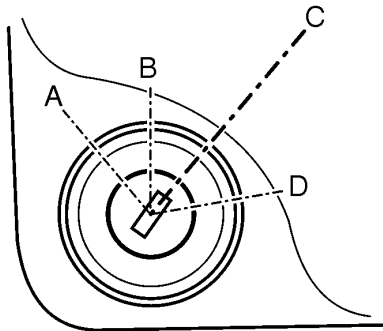

W3006728

Switch Position C = Drive + Preheat (Volvo Engine Only)

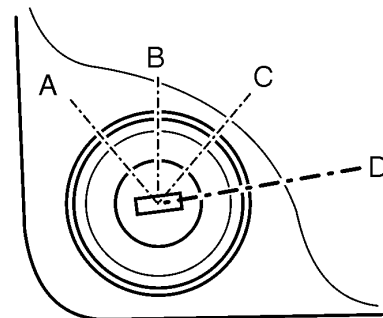

W3006724

Switch Position D = Start

Remote Start and Stop, VAH and VHD

A remote start/stop feature has been released for the VAH and VHD models equipped with an I-Shift transmission. This feature must be specified at the time the vehicle ordered. No retrofits are possible. The remote start/stop feature enables the operator to start or stop the vehicle's engine from outside of the cab for the purpose of reduced idling while the vehicle is in a standby mode such as off loading vehicles from a transport trailer.

For the remote start/stop to function the following preconditions must be met:

- The key switch (ignition switch) must be in position II
- The transmission must be in neutral
- The hood must be closed

PTO (Power Take-Off)

PTO (Power Take-Off) and idle shutdown settings have two effects on the behavior of the remote start feature.

1. If PTO mode is enabled via the cab dash switch AND idle shutdown is configured to be OFF in PTO mode, then remote start will always work provided the safety conditions are fulfilled.

2. If PTO mode is enabled via the cab dash switch AND idle shutdown is configured to be ON in PTO mode, then an idle timer will begin. If the idle timer runs out, the ECU will deactivate the fuel pump and fuel injectors, shutting the vehicle down. If this occurs, the key must be cycled before the ECU will permit a remote start.

Connector/Mating Part Information

Connector/Item	Supplied on vehicle	Mate required to plug into vehicle
Connector #3	Connector #3 Packard 150–GT series (unsealed), 16–way; Female housing & Terminals Packard 150–GT series (unsealed), 16–way; Male housing & terminals	Packard 150–GT series (unsealed), 16–way; Male housing & terminals
Housing Assembly	Packard PN 15332177 Volvo PN 20481359	Packard PN 15332182 Volvo PN 20481361
Terminals	Packard 12191812 (0.75–1.00 mm ²)	Packard 15304702 (0.75 – 1.00 mm ²) Packard 15304701 (0.35 – 0.50 mm ²)
Connector #4	Packard 150–GT series (unsealed), 16–way; Male housing & terminals	Packard 150–GT series (unsealed), 16–way; Female housing & terminals
Housing Assembly	Packard PN 15332182 Volvo PN 20481361	Packard PN 15332177 Volvo PN 20481359
Terminals	Packard 15304702 (0.75 – 1.00 mm ²)	Packard 12191812 (0.75 – 1.00 mm ²) Packard 12191811 (0.35 – 0.50 mm ²)

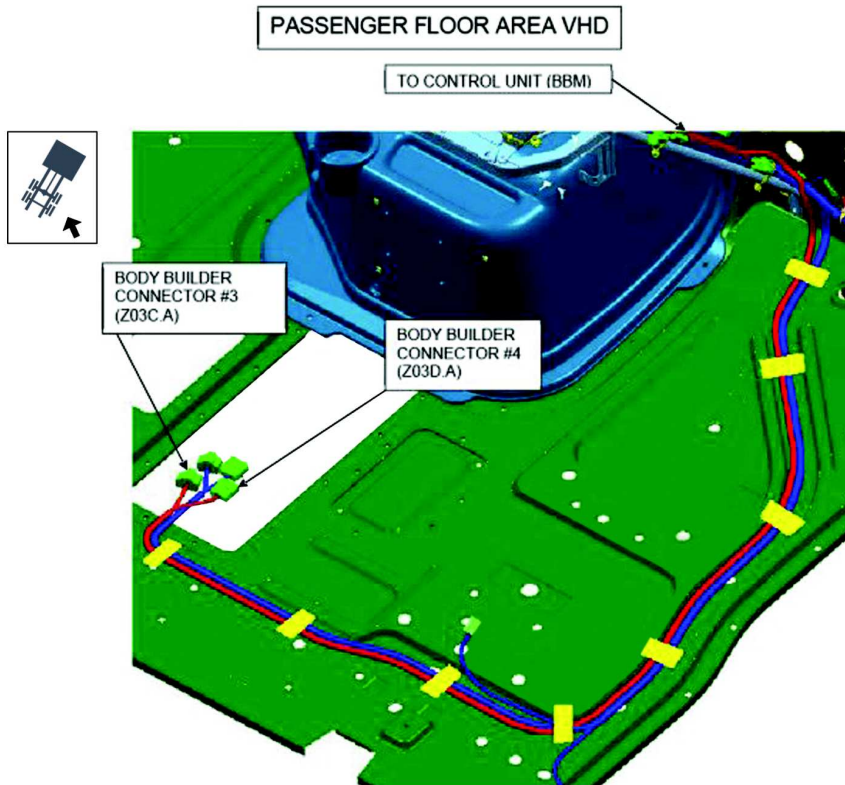

W3126665

Connector # 3 Pinouts

Pin	Circuit	Description	Notes
A	X03EA21	Ground return for all BBM-connected Inputs.	
B	MB5A1	+V Power for BBM-connected Switches	Limit to –10 switches per +V output
C	MB19A1	+V Power for BBM-connected Switches	Limit to –10 switches per +V output
D	MA18A1	PTO2 Input/Enable	All PTO inputs are Active High; See VECU (ELCE-PK) for PTO1 Input/Enable
E	MA19A1	PTO3 Input/Enable	
F	MA20A1	PTO4 Input/Enable	
G	MA4A1	PTO1 Mode Input	Active High Inputs
H	MB21A1	PTO2 Mode Input	
J	MA3A1	PTO3 Mode Input	
K	MA5A1	PTO4 Mode Input	
L	MB2A1	PTO2 Output	Active Low Outputs; limit to 1 Amp per output. See VECU (ELCE-PK) for PTO1 Input/Enable
M	MB3A1	PTO3 Output	
N	MB4A1	PTO4 Output	
P	MA1A1	Remote PTO Engine Speed Decrement	Active High Inputs; act on PTO2–4 only
R	MA2A1	Remote PTO Engine Speed Increment	
S	MA6A1–0.8	Remote Start Input	Active High

Connector # 4 Pinouts

Pin	Circuit	Description	Notes
A	MA6A1	Engine Shutdown #1 Input	Normally Open (N.O.) Switch to +V
B	MA27A1	Engine Shutdown #2 Input	Normally Closed (N.C.) Switch to Ground
C	MA7A1	Forced Idle/Throttle Interlock Input	Active High Input
D	MA17A1	Engine Speed Limit Input	Active High Input
E	MA25A1	Engine Torque Limit Input	Active Low Input
F	MA26A1	Road Speed Limit Input	Active Low Input
G	MA24A1	PTO Neutral Interlock Input	Active Low Input
H	MA28A1	PTO Low Split Gear Interlock Input	Active Low Input
J	MA29A1	Split Shaft PTO Input	Active High Input
K	MB12A1	Remote Throttle Enable Input	Active Low Input
L	MB10A1	Remote Throttle V-Ref (5V) Output	Use twisted-trio wiring for these three circuits
M	MB9A1	Remote Throttle Sensor/Signal Input	
N	MB22A1	Remote Throttle Ground Reference	
P	MB28A1	Road Speed Output ("C3" Output)	Active High Output
R	MB16A1	System Warning Output	Active Low Output
S	MB18A1	Databus Triggered Output	Active Low Output

Notes

Parameters

Settings: VECU

CUK	EV ENG STOP FR CHASS SIGN	1
CUM	ENG STOP DEM FILTER TIME	1
CUN	ENG STP DEM VEHL SPD COND	5
FNN	EN EMS CONTR EXT START	0
IHM	PARK BRAKE FOR REMOTE ENG	1
IHN	VEHICLE SPEED SHUTDOWN	0
IL	ENABLE SHUTDOWN INPUT	0
ZA	PTO OUT 2 MOUNTED	2
ZU	ENG REMOTE START P BRAKE	1
ZV	ENG REMOTE START NEUTRAL	1
P1 HUM	PTO Switch Override	1
AM	IDLE SHUTDOWN TIME	120
FND	LEAVE OVERRIDE OPTION	2
FPJ	IDS ENABLE PTO1 OVERRIDE	0
FPK	IDS ENABLE PTO2 OVERRIDE	1

Notes

Body Builder Module 2016

Wiring Diagram: BM

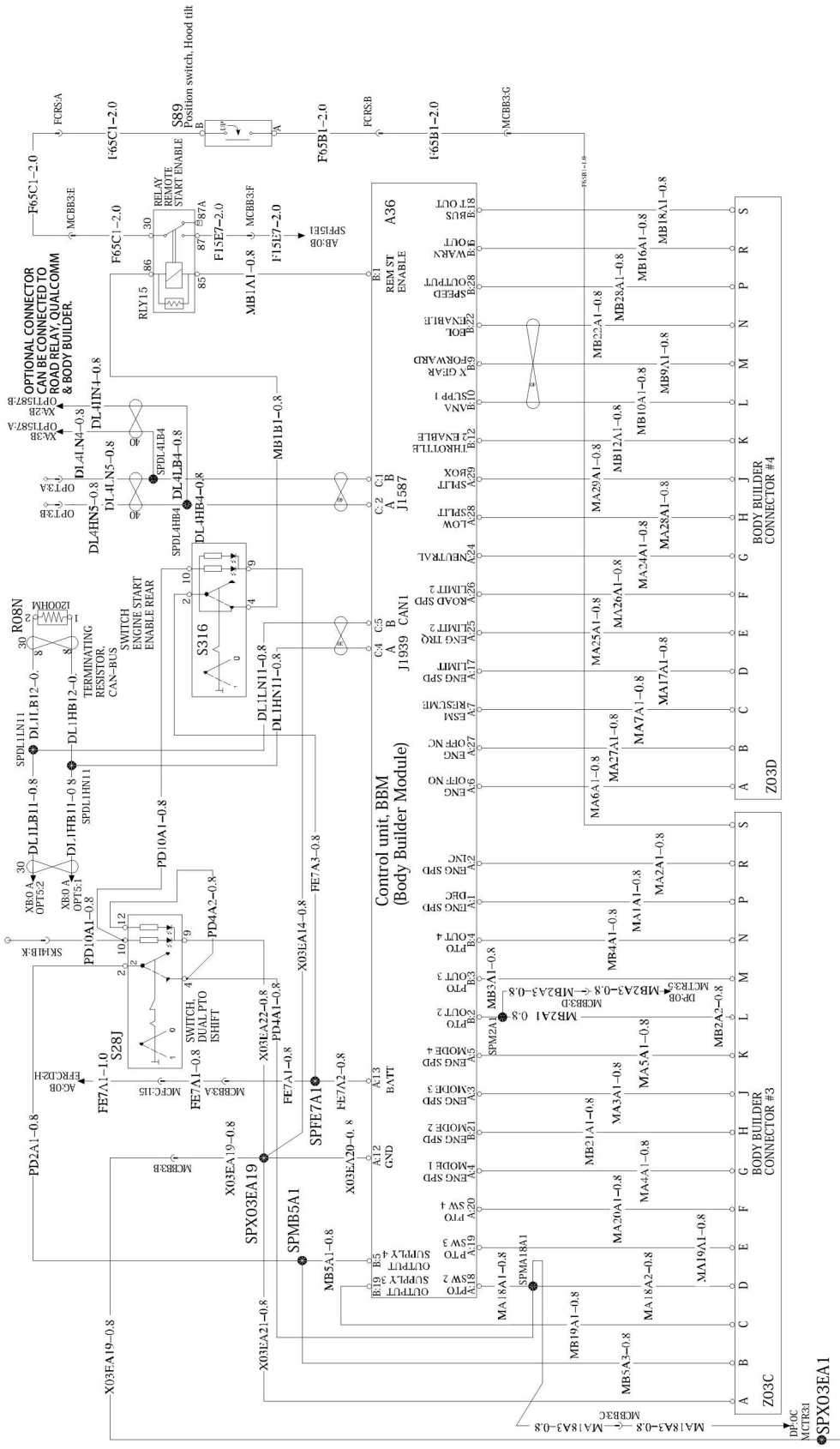

W0114616

ISO 26262 Functional Safety Manual

Scope

This section describes the functional safety aspects related to the interface between the vehicle and the body builder equipment.

ISO 26262 is the functional safety standard for road vehicles. Functional safety addresses safety related functionality implemented in electronics and software. Volvo Trucks has during 2018 initiated development of new vehicle functions and systems according to ISO 26262 after the standard became applicable to trucks, buses and trailers. Before ISO 26262, Volvo Trucks followed other internal processes addressing functional safety.

Introduction

The truck will gradually be made compliant to ISO 26262. However, it will take several years until the complete truck is compliant to the standard.

The status of the truck related to functional safety with regards to ISO 26262 will be described in this document. Continuous updates will be made to reflect the current status of the truck.

The ASILs of the body builder interface characteristics will be documented and it will be described in which sense the interfaces meet the different ASILs. This document will also contain information on requirements and constraints for the usage of the body builder interface. In case specific safety measures have to be applied by the body builder, this shall be stated in this document.

When a body builder needs anything that is not described or when the ASIL of the characteristic is not according to the body builders expectations, the body builder shall contact Volvo Trucks for guidance. This document will be referenced from other body builder documents when applicable.

Current status of the truck in relation to ISO 26262

The existing trucks are developed according to Volvo Trucks internal process addressing functional safety, applicable before ISO 26262.

Presently no functions or systems in the trucks have been developed according to ISO 26262.

VOLVO

Volvo Trucks North America

<http://www.volvotrucks.com>